

STARLINE SERIES HP

High Power Busway Product Selection Guide

TABLE OF CONTENTS

STARLINE SERIES HP SYSTEM	3
System Solution	3
Busway Break Out	4
Why Busway?	5
Why Starline	7
INTRODUCTION	9
Overview	10
Application	11
GENERAL DATA	12
General Specifications	14
Joint Connection	15
Grounding and Harmonics	16
Plating/Painting	16
IP Code (Degree of Protection)	17
COMPONENT	18
Feeder	18
Flanged End	19
Fittings	24
Hanger	28
Bus plug	30
TECHNICAL DATA	34
Impedance and Voltage Drop	35
Short Circuit Strength	36
INSTALL INFORMATION	37
Joint Connection	37
CERTIFICATION & SPECIFICATION	38

STARLINE SERIES HP SYSTEM SOLUTION



INDUSTRY

The Starline Series HP features easy to install and ensures large capacity of energy transmission while providing space efficiency.

We also can provide real time monitoring system using temperature and power monitoring.



PLANT

Optimal solution for factory and plant power distribution line due to its special feature satisfying IP68 and non explosive design.

NSPB and CR Way type normally used for chemical and power plant especially indoor and outdoor substation room.



DATA CENTER

The flexibility and expandability as well as easy maintenance property of the busway system provides the best alternative to improve the existing problems of the conventional power cable system of data centers, which requires constant extension, reinstallation and capacity modification of loads.



HIGH RISE BUILDING/COMMERCIAL

Although the demands for more electricity for families are growing, the space for EPS area has reduced. Due to the change, the need for busways and multi boxes have increased.



AIRPORT

In order to secure the stable power supply of the airport, the busway system provides the best customized solutions by installing high voltage busways at the transmission, low voltage busways at the control tower and general commercial buildings.

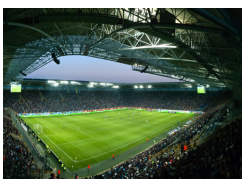

STADIUM

The needs for a busway system has been growing for its benefit such as large capacity of power transmission, providing a stable power supply for various loads and an eco friendly property as well as economical quality.

BUSWAY PRODUCT LINE-UP

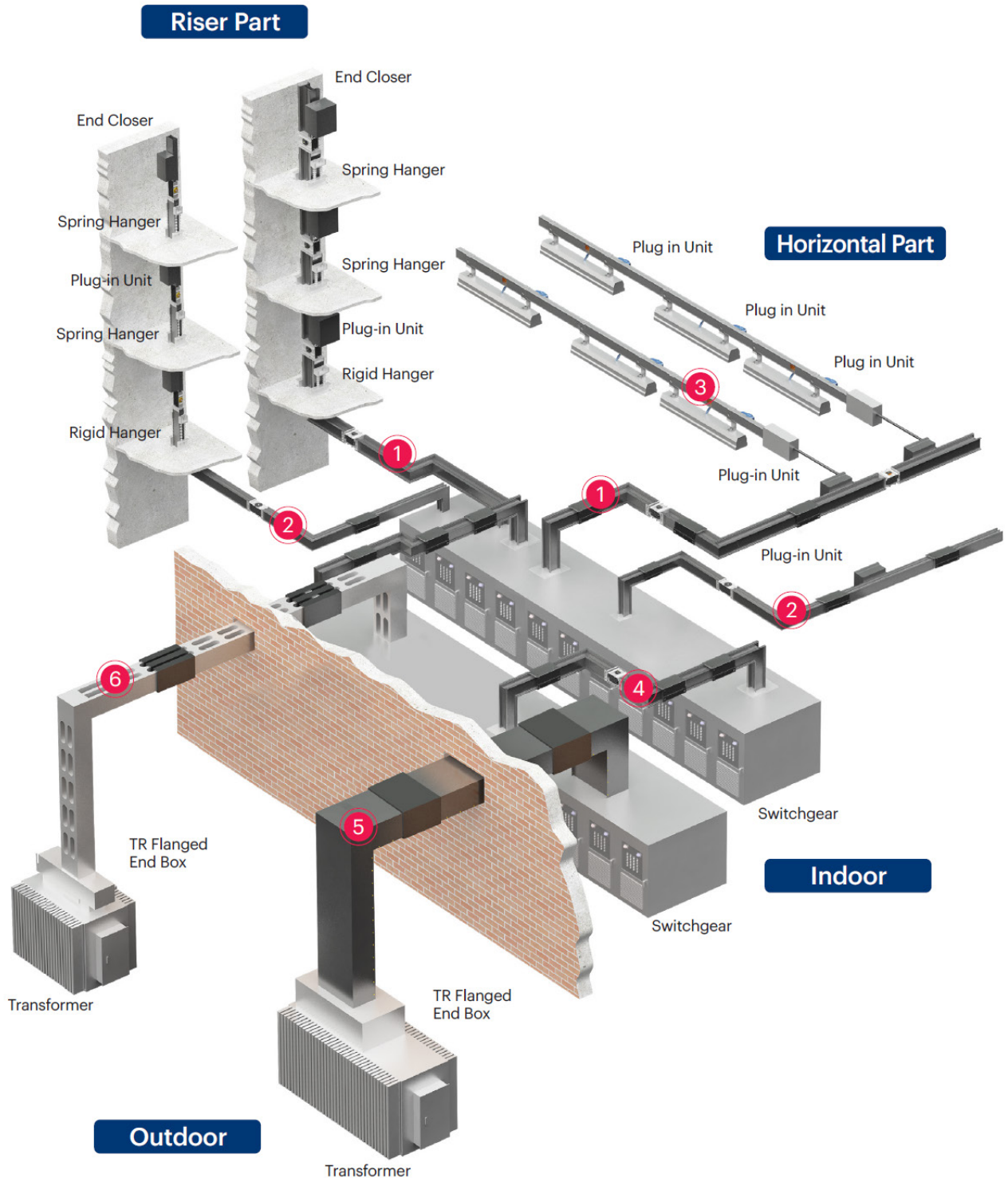

WHY BUSWAY?

EASY DISTRIBUTION OF LOADS

When supplying power using cables, each load has to be connected individually to cables which wastes space, and requires an additional distribution panel.

On the other hand, busways allow electricity to flow from main line and branch through the plug-in unit, simplify the circuit configuration and significantly reduce the cost.

CABLE WIRING SYSTEM

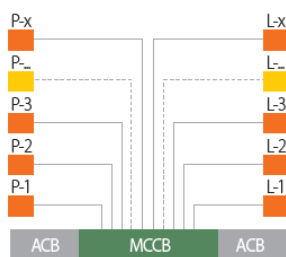

- One-to-one correspondence of power supply and loads
- Additional lines are needed in case of a load change

ACB : Air Circuit Breaker, MCCB : Molded Case Circuit Breaker

BUSWAY SYSTEM

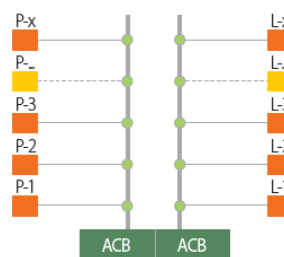

- One-to-many correspondence of power supply for specific power supply
- Additional lines are not necessary in case of a load change

EASY INSTALLATION

Cable installation requires cable pulling and cable tray job which are difficult and require long-term construction period.

On the other hand, busway installation method is very simple. Just connect a certain length of feeder, reducing the amount of labor hours required as shown in the comparison graph.



COMPACT

The compact design of the busway system provides high space efficiency at up to 50% compared to the cables. While cables require larger space to install multi lines as well as additional space for coiling areas, the busways use proper fittings to maximize space efficiency.



ADAPTABILITY TO VARIOUS INSTALLATION ENVIRONMENT WITH CONVENIENCE

The busway system comes with various fittings such as elbow, off-set and tee, and can transmit high capacity currents without electrical and mechanical loss.

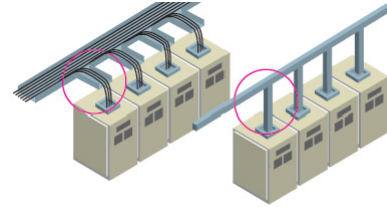

EXCELLENT SHORT CIRCUIT STRENGTH

The busway system has a high tolerance for short circuit. Its stability and reliability make it perfect for a high capacity energy transmission system.

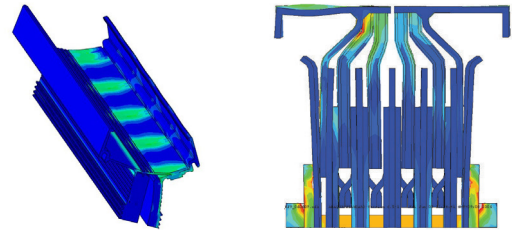

HIGH CURRENT DENSITY

Cable maximum allowable current ampacity limit is 1000A, in case requires higher current, additional lines is needed. Busway systems can transmit up to 6000A, by providing high current density, saving cost and time.

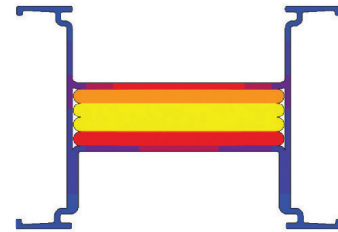

EASY MAINTENANCE

The design of the busway system makes it easy to detect abnormalities during installations, and ensures easy maintenance. When humidity or dust causes a malfunction on the system, the easy-to-maintain design allows replacing only the damaged part.

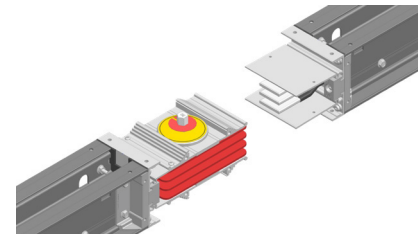

OUTSTANDING FEATURES OF EMC AND EMI

Unlike cables, busways do not require a shield, instead, the housing itself performs as a shield which enhances the features of EMC and EMI.



TOTAL SOLUTION

- Our engineers will be available from the onset of the project to assist with questions and provide timely support.
- The Series HP Support Team will offer full services for design, production, installation and testing for complete customer satisfaction.
- Starline Services Group offers a series of post-sale support packages to ensure successful start-up and maintenance of the product.

PROCESS

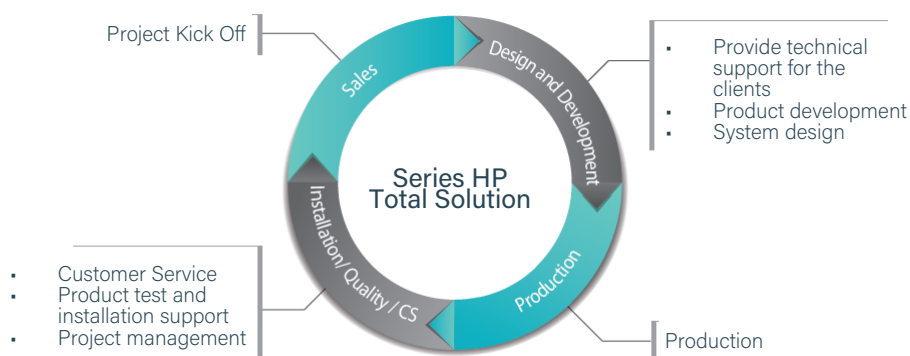

TECHNICAL EXCELLENCE

Unparalleled Reliability

- UL Certified
- Safe use in hazardous zones
- Uses qualified insulation such as epoxy and PET film for efficient insulation

Eco Friendly

- Fully recyclable
- Halogen free
- Does not contain RoHS 6 hazardous substance
- No toxicity in fire & Fire-Retardant
- Non Explosive

Total Engineering Technology

- Provide the optimal design by experienced engineers
- Unique and exclusive design program for the busway system
- Design based on structure stability inspection
- The excellent heat -radiating property of the aluminum housing, which ensures large capacity of power transmission
- Low weight & low cost
- Easy installation
- Deployable where access is difficult
- Automated epoxy insulation facility
- Unique joint kit connections



SERIES HP

Overview

Application

General Data

General Specifications

Joint Connection

Grounding and Harmonics

Plating/Painting

IP Code (Degree of Protection)

Feeder

Flanged End

Fittings

Hanger

Bus Plug

Etc

Technical Data

Joint Connection

Certification & Specification

OVERVIEW

SERIES HP BUSWAY

The system components are designed to carry voltage range below 600VAC, and to carry the current range of 630A to 6000A. Joint kit connections provide more space to connect which reduce the contact resistance to its minimum while connecting products. The standard offering for the system is IP54 rated, however, it can be upgraded to an indoor or outdoor IP65 rating on request. Series HP uses epoxy powder for insulation.

COMPACT SIZE

Series HP uses a high conductivity conductor and an effective heat radiating housing profile which allow more compact size than other busway models.

The product's light weight makes installation easier even in small space.

ECONOMICAL AND EASY INSTALLATION

Series HP uses aluminum housing and joint kit connections to enable easy, quick and low cost installation.

EASY DISTRIBUTION LOADS

Busways allow electricity to flow from main line and branch through plug-in units, simplifying the circuit configuration and significantly reducing the cost.

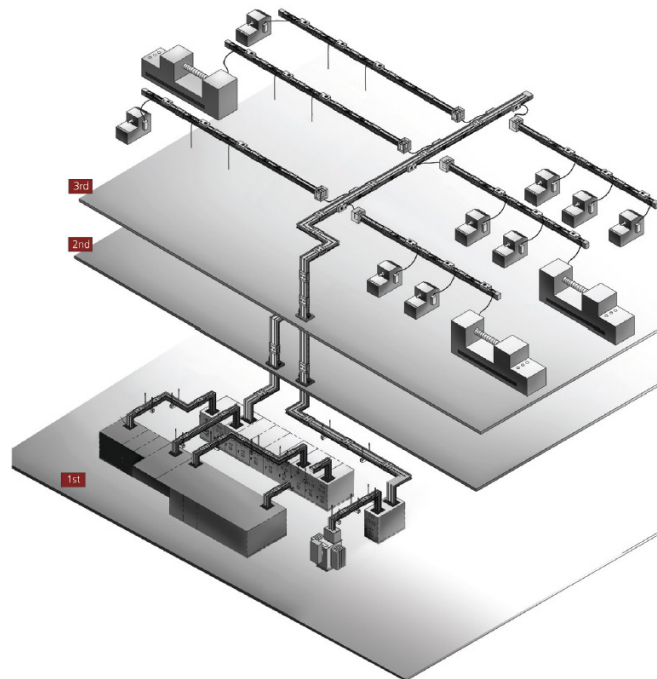

APPLICATION

FACTORY / PLANT ETC.

- The busways can be applied to a vast range of industries such as semiconductor, display and petrochemical plants.
- The temperature and the power supply monitoring system allows for easy maintenance.
- The system provides high space efficiency, and allows a significantly reduced installation period.

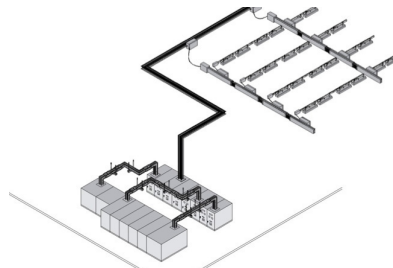
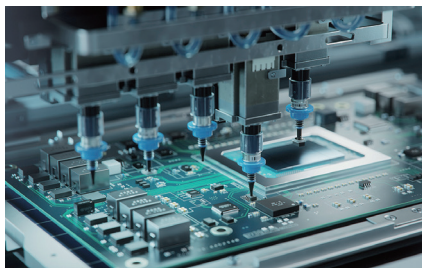

COMMERCIAL / INDUSTRIAL BUILDING

- Provides excellent space efficiency.
- The busways can be applied to high-rise buildings, office buildings, and data centers.
- Multi-box can be applied on request.

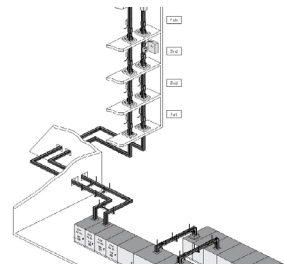

ELECTRICAL ROOMS

- The busway can be installed both horizontally and vertically at the electrical room.
- The maximized safety features are seismic-proof and explosion-proof.
- Provides excellent space efficiency and easy installation compared to cables.

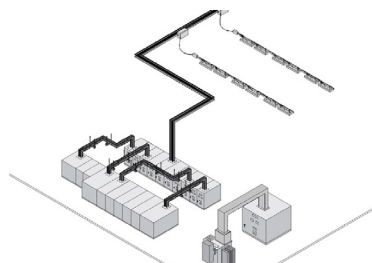

GENERAL DATA

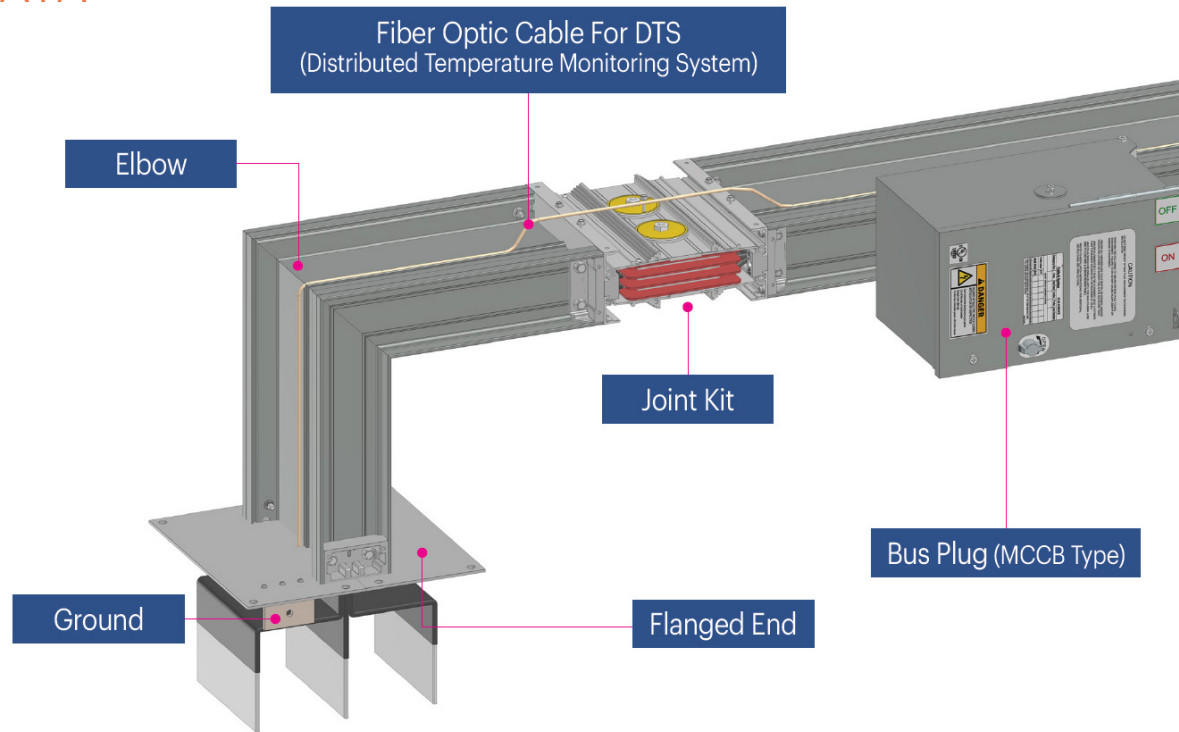

HIGH CURRENT DENSITY

The busway has a compact design utilizing effective heat-radiating housing profile and can carry from 630A up to 6000A with reduced loss of electric power.

LOW VOLTAGE DROP AND HIGH SHORT CIRCUIT STRENGTH

Busways provides efficient power transportation through optimal design. Voltage drop is very low due to low impedance.

The system is designed to carry high short circuit ratings.

PERMISSIBLE OPERATING TEMPERATURE

The cross sectional areas of the conductor and housing profile are designed to meet the standard permissible operating temperature of UL857.

ECO-FRIENDLY

Series HP is RoHS certified and does not utilize hazardous components or materials, such as lead, cadmium, mercury, chrome, PBBs and PBDEs.

STANDARD

- ANSI/UL857
- NEMA BU 1.1 Busways
- IEC 61439-6
- Busbar Trunking Systems
- BS EN 61439 Busways
- AS / NZS 3439.2

SERVICE CONDITION

- Ambient Temperature : -59°F ~ 131°F,
-15°C ~ 55°C
- Relative Humidity : 95% or below
(When the service condition of the environment does not meet the requirements listed above, please contact our design team.)

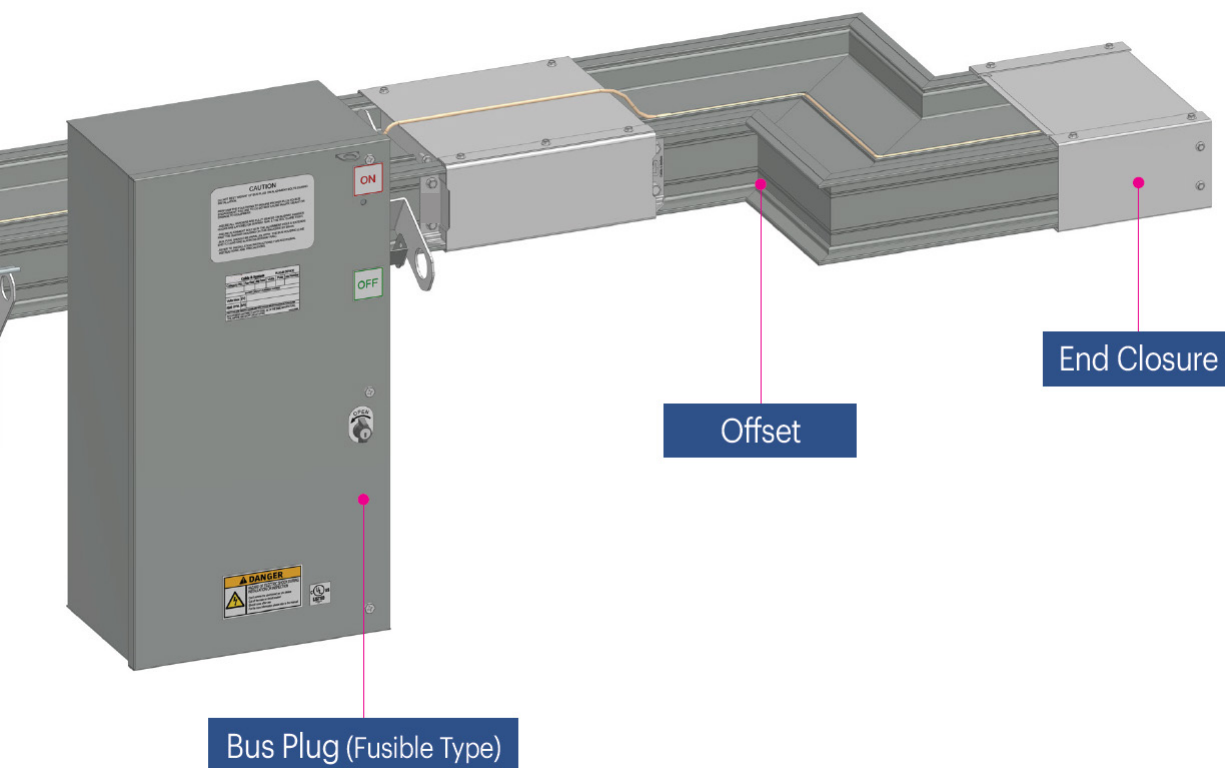

CONDUCTOR

Cu - Conductivity : over 96% , Purity over 99.9%

Al - Conductivity : over 61% , Purity over 99.6%

INSULATION PROPERTIES

Epoxy Class B (266°F/130°C)

HOUSING

Series HP uses an effective heat-radiating aluminum housing profile which produces excellent mechanical strength and heat radiation. The aluminum housing can be used as a electrical ground conductor due to its high level conductivity and cross sectional areas. An optional optical fiber temperature sensor can be installed at the housing.

CONNECTION

Joint Kit

Double Head Bolt / Visible Label / Disc Spring

Assembly Torque : 694~868lbf.in / 78~98N.m /

800~1000kgf.cm

GENERAL SPECIFICATIONS

Each of the busway's conductors are Class B Epoxy insulated to a thermal rating of 266F/130C for each phase and protected with an aluminum enclosure.

The design is a sandwich type structure and can be applied to voltages below 600VAC and range is between 630 and 6000A.

The system and its connections are designed to a standard rating of IP54, with additional ingress protection available.

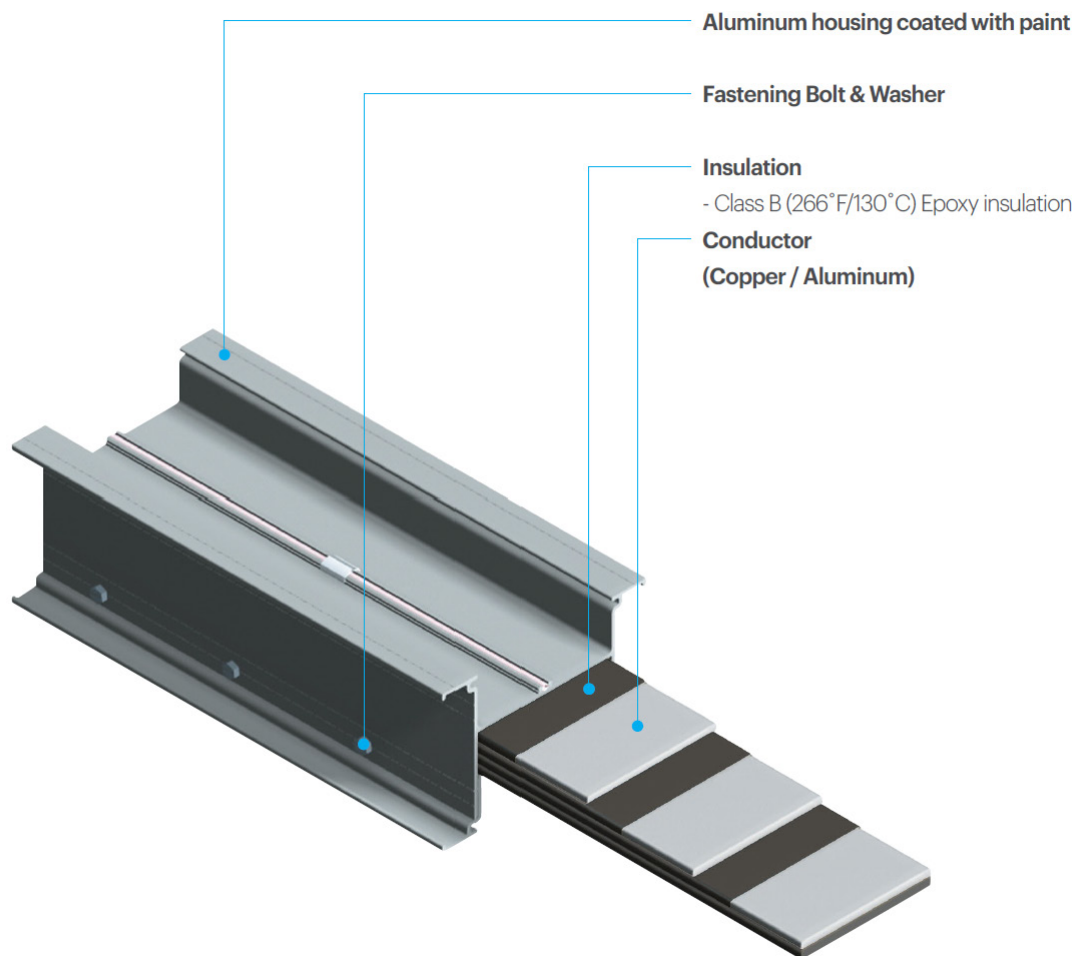

JOINT CONNECTION

FEATURE

Joint kit plates and conductors are standard tin plated, with the option of silver plating available. This prevents discoloration and corrosion of the joint plate. In order to ensure easy maintenance and reliability, double-headed bolts and visible labels are used to check the application, and a disc spring allows even connection of the contact surface.

DOUBLE HEADED BOLTS

Double-headed bolts are used to ensure a proper torque level when installing the joint kit. If a torque wrench applies a pressure of 694~868lbf.in / 78~98N.m / 800~1000kgf.cm to the outer bolt head, the head of the outer bolt and the tag attached to it will be sheared off automatically. Thus, it allows visual inspection for the proper application of the bolts at the connection. The remaining bolt head can be re-used when tightened to 694lbf.in/800kgf.cm using a torque wrench. After installing joint cover, a red line at the end of double headed bolt should be seen through the inspection cap.

Joint Kit

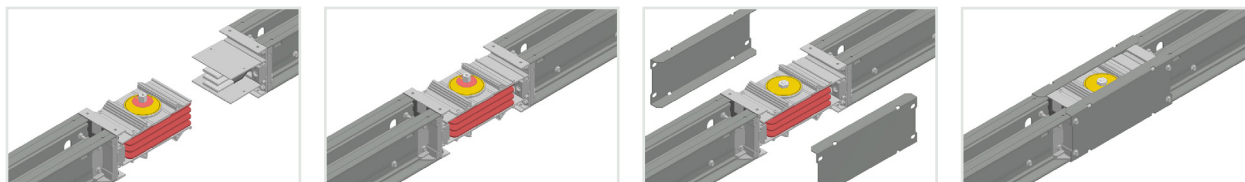

NUMBER OF DOUBLE HEADED BOLTS

Number of D.H bolts		1	2	4	6
Ampere (A)	AL	630, 800, 1000, 1250	1600, 2000, 2500	3200, 3600, 4000	5000, 6000
	CU	630, 800, 1000, 1250, 1600, 2000	2500, 3200, 3600, 4000	5000	6000

Precaution

- Be sure to clean the interior of the connections prior to installation.
- Do not twist the joint kit while inserting it or after it has been installed.
- Excessive pressure during installation may break the kit.
- Make sure that the double-headed bolts and the red tags are intact.
- If proper torques are not applied at the connection, it may cause heat during operation.

GROUNDING AND HARMONICS

The entire enclosure of the Series HP is made of aluminum, and the cross-sectional area of the enclosure is more than 100% of the conductor of each phase.

Thus, the aluminum enclosure of the busway serves as a grounding conductor of more than 100% and simultaneously improves the heat dissipation efficiency of the conductor. If additional grounding of 50% or 100% capacity is required, additional internal ground bars can be added to the assembly. Non-linear loads on the power distribution system can increase the amount of harmonic current generated. A 200% Neutral option is available.

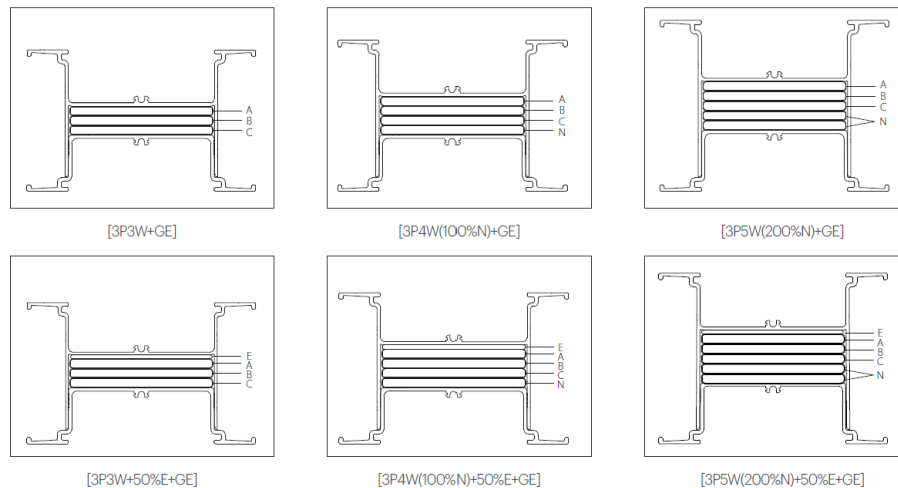

PLATING/PAINTING

PLATING

Standard tin plating is applied at taps, plugs and connections of conductors using an electroplating method to maintain the electrical characteristics and to prevent corrosion. Silver plating is available on request.

PAINTING

In order to improve heat radiation and to prevent corrosion, apply polyester-epoxy (hybrid) powder coating after treating the surface. A wide range of color options are available to meet the needs of our clients.







* Standard color : ANSI61

DEGREE OF PROTECTION









International protection degree codes provided by IEC 60529 (Degree of Protection Provided by Enclosure-IP Code)

IP □ □

Solid Particle Protection

-  0 No Protection
-  1 Protection against 50mm diameter solid particles. (back of a hand)
-  2 Protection against 12mm solid particles. (fingers)
-  3 Protection against 2.4mm solid particles. (tools or thick wires)
-  4 Protection against 1mm solid particles. (tools or most wires)
-  5 Protection against dust.
-  6 Complete protection against dust.

Liquid Ingress Protection

-  0 No Protection
-  1 Protection against falling drops of water.
-  2 Protection against falling drops of water with an enclosure tilted at a 15-degree angle from a vertical line
-  3 Protection against spray at a 60-degree angle from a vertical line
-  4 Protection against water splashed from all directions.
-  5 Protection against low pressure jets of water from all directions.
-  6 Protection against strong jets of water from all directions.
-  7 Protection against the effects of immersion between 15.0 centimeters and 1.0 meter.
-  8 Protection against longer periods of immersion under pressure.

INDOOR TYPE

This product is designed to withstand life waterproofing such as upper leaks and sprinklers, satisfying IP54 requirements

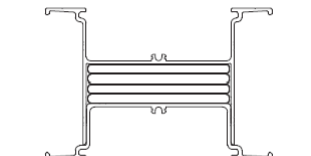

OUTDOOR TYPE

The outdoor product is designed with a double enclosure. This feature makes it naturally protected from dust and gas, and is an ideal solution for oil and gas plants.

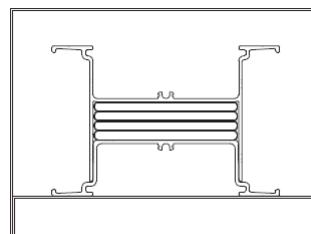

FEEDER

Sectional View

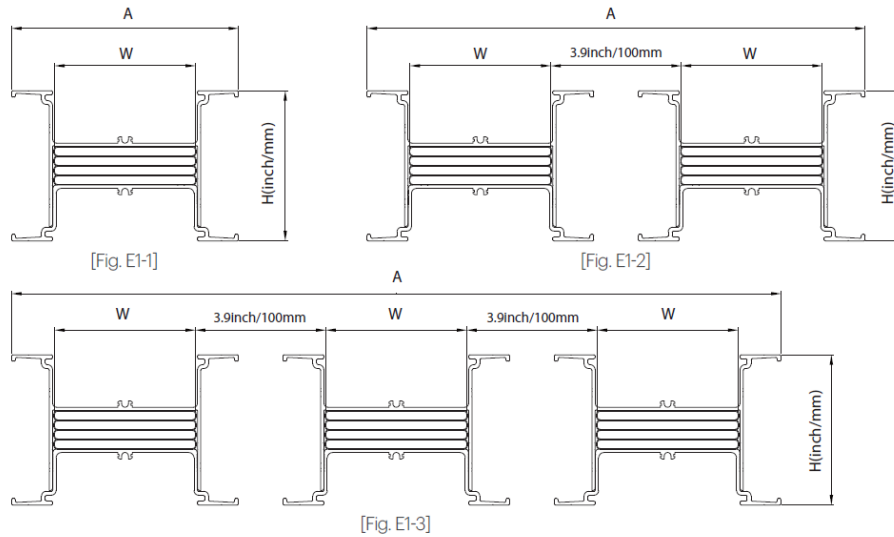

Ampere(A)	t		W		A		3W		4W		4W+50%E		4W+100%E		Fig.				
	inch	mm	inch	mm	inch	mm	lb/ft	kg/m	lb/ft	kg/m	lb/ft	kg/m	lb/ft	kg/m					
AL	0.25	6.35	630	1.61	41	4.21	107	4.57	6.81	5.23	7.8	5.51	8.21	5.87	8.75	E1-1			
			800	2.44	62	5.04	128	5.64	8.41	6.58	9.81	6.99	10.43	7.5	11.18				
			1,000	3.39	86	5.98	152	6.84	10.2	8.09	12.06	8.66	12.91	9.3	13.87				
			1,250	4.25	108	6.85	174	8.43	12.57	9.96	14.86	10.67	15.91	11.49	17.14				
			1,600	6.46	164	9.06	230	11.61	17.31	13.9	20.73	14.97	22.33	16.12	24.04				
			2,000	8.27	210	10.87	276	14.02	20.91	16.92	25.23	18.29	27.27	19.72	29.41	E1-2			
			2,500	4.96	126	16.46	418	18.24	27.2	21.8	32.51	23.46	34.98	25.3	37.73				
			3,200	6.46	164	19.45	494	22.64	33.77	27.22	40.6	29.38	43.81	31.78	47.39				
			3,600	7.24	184	21.02	534	24.76	36.93	29.87	44.55	32.28	48.14	39.7	59.2				
			4,000	8.27	210	23.07	586	27.49	41	33.29	49.64	36.04	53.74	44.4	66.22				
AL	0.25	6.35	5,000	7.24	184	32.2	818	36.87	54.98	44.53	66.41	48.15	71.8	59.33	88.48	E1-3			
			6,000	8.27	210	35.28	896	40.96	61.09	49.66	74.06	53.79	80.21	66.47	99.13				
			CU	0.25	6.35	630	1.61	41	4.21	107	8.36	12.49	10.29	15.34	11.2	16.7	13.95	20.81	E1-1
						800	1.61	41	4.21	107	8.36	12.47	10.29	15.34	11.2	16.7	13.95	20.81	
						1,000	2.24	57	4.84	123	10.61	15.83	13.23	19.73	14.48	21.6	18.2	27.14	
						1,250	2.87	73	5.47	139	12.84	19.15	16.14	24.07	17.74	26.45	22.52	33.59	
1,600	4.25	108				6.85	174	18.15	27.06	22.92	34.18	25.24	37.64	27.55	41.09				
2,000	5.71	145				8.31	211	23.46	34.98	29.84	44.5	32.96	49.16	36.06	53.77	E1-2			
2,500	7.68	195				10.28	261	30.76	45.87	39.3	58.61	43.5	64.87	47.72	71.17				
3,200	4.25	108				15.04	382	35.96	53.62	45.58	67.98	50.28	74.98	55.11	82.18				
3,600	4.96	126				16.46	418	41.04	61.21	52.22	77.87	57.67	86.01	63.1	94.1				
4,000	5.71	145				17.95	456	46.43	69.24	59.22	88.32	65.49	97.67	71.77	107.03				
CU	0.25	6.35	5,000	7.68	195	21.89	556	61.04	91.03	78.15	116.55	86.56	129.08	94.98	141.64	E1-3			
			6,000	6.46	164	29.84	758	77.93	116.21	99.76	148.77	110.39	164.62	121.15	180.67				

* H : 107.5mm/4.23"(3W+GE, 3W+50%E) / 115mm/4.53"(4W+GE, 4W+50%E) / 130mm/5.12"(4W+100%E, 3P+200%N)

FLANGED END

Flanged end is connected to either a transformer or panel. Dimension details are listed below.

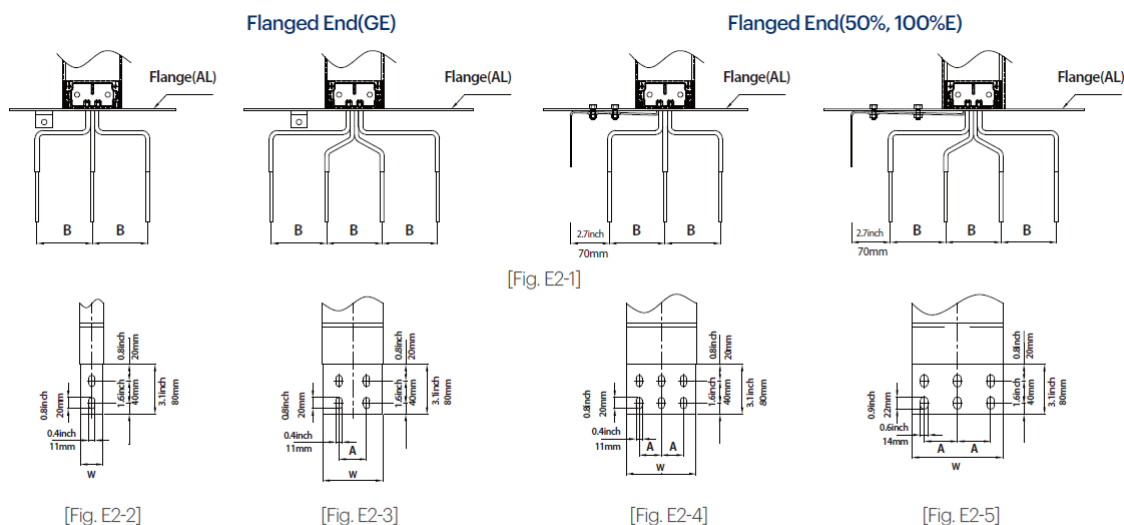

Ampere(A)	t		W		A		B		Fig.	
	inch	mm	inch	mm	inch	mm	inch	mm		
AL	0.25	6.35	1.61	41	-	-	3.94	130	E2-2	
			2.44	62	-	-				
			3.39	86	1.57	40				
			1,250	4.25	108	1.97	50	5.12	130	E2-3
			1,600	6.46	164	2.36	60			
			2,000	8.27	210	2.76	70			
			2,500	4.96	126	1.57	40			
			3,200	6.46	164	2.36	60			
			3,600	7.24	184	2.36	60			
			4,000	8.27	210	2.76	70			
5,000	7.24	184	2.36	60						
6,000	8.27	210	2.76	70						
CU	0.25	6.35	1.61	41	-	-	3.94			
			1.61	41	-	-				
			2.24	57	-	-				
			1,250	2.87	73	1.57	40	5.12	130	E2-3
			1,600	4.25	108	1.97	50			
			2,000	5.71	145	1.97	50			
			2,500	7.68	195	2.76	70			
			3,200	4.25	108	1.97	50			
			3,600	4.96	126	1.57	40			
			4,000	5.71	145	1.97	50			
			5,000	7.68	195	2.76	70			
			6,000	6.46	164	2.36	60			

* Contact our engineering staff for more detail

FLANGED END (INCH)

Drilling Pattern for Flanged End

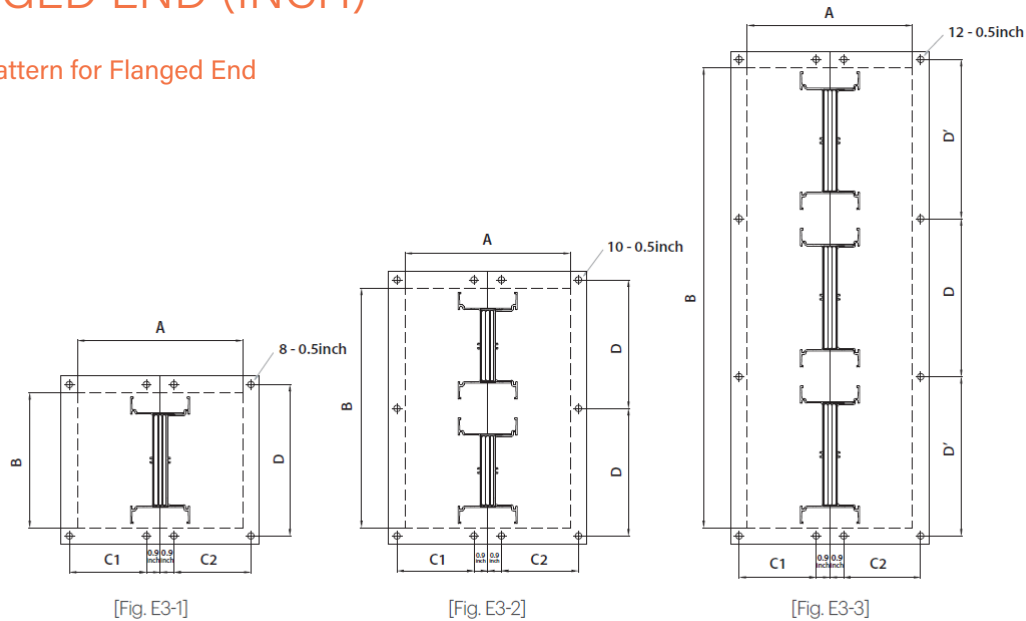

(inch)

Conductor	Rating (A)	3W Standard Dimension					4W Standard Dimension					4W+50%E, 100%E Standard Dimension					Fig.	
		A	B	C1, C2	D	D'	A	B	C1, C2	D	D'	A	B	C1	C2	D		D'
AL	630	9.45	4.8	4.33	5.98	-	13.39	4.8	6.3	5.98	-	16.14	4.8	9.06	6.3	5.98	-	E3-1
	800	9.45	5.63	4.33	6.81	-	13.39	5.63	6.3	6.81	-	16.14	5.63	9.06	6.3	6.81	-	
	1,000	9.45	6.57	4.33	7.76	-	13.39	6.57	6.3	7.76	-	16.14	6.57	9.06	6.3	7.76	-	
	1,250	9.45	7.44	4.33	8.62	-	13.39	7.44	6.3	8.62	-	16.14	7.44	9.06	6.3	8.62	-	
	1,600	9.45	9.65	4.33	10.83	-	13.39	9.65	6.3	10.83	-	16.14	9.65	9.06	6.3	10.83	-	
	2,000	9.45	11.46	4.33	12.64	-	13.39	11.46	6.3	12.64	-	16.14	11.46	9.06	6.3	12.64	-	E3-2
	2,500	11.81	17.05	5.51	9.11	-	16.93	17.05	8.07	9.11	-	19.69	17.05	10.83	8.07	9.11	-	
	3,200	11.81	20.04	5.51	10.61	-	16.93	20.04	8.07	10.61	-	19.69	20.04	10.83	8.07	10.61	-	
	3,600	11.81	21.61	5.51	11.4	-	16.93	21.61	8.07	11.4	-	19.69	21.61	10.83	8.07	11.4	-	
	4,000	11.81	23.66	5.51	12.42	-	16.93	23.66	8.07	12.42	-	19.69	23.66	10.83	8.07	12.42	-	
CU	5,000	11.81	32.8	5.51	11.22	11.38	16.93	32.8	8.07	11.22	11.38	19.69	32.8	10.83	8.07	11.22	11.38	E3-3
	6,000	11.81	35.87	5.51	12.24	12.4	16.93	35.87	8.07	12.24	12.4	19.69	35.87	10.83	8.07	12.24	12.4	
	630	9.45	4.8	4.33	5.98	-	13.39	4.8	6.3	5.98	-	16.14	4.8	9.06	6.3	5.98	-	E3-1
	800	9.45	4.8	4.33	5.98	-	13.39	4.8	6.3	5.98	-	16.14	4.8	9.06	6.3	5.98	-	
	1,000	9.45	5.43	4.33	6.61	-	13.39	5.43	6.3	6.61	-	16.14	5.43	9.06	6.3	6.61	-	
	1,250	9.45	6.06	4.33	7.24	-	13.39	6.06	6.3	7.24	-	16.14	6.06	9.06	6.3	7.24	-	
1,600	9.45	7.44	4.33	8.62	-	13.39	7.44	6.3	8.62	-	16.14	7.44	9.06	6.3	8.62	-		
E3-2	2,000	9.45	8.9	4.33	10.08	-	13.39	8.9	6.3	10.08	-	16.14	8.9	9.06	6.3	10.08	-	
	2,500	9.45	10.87	4.33	12.05	-	13.39	10.87	6.3	12.05	-	16.14	10.87	9.06	6.3	12.05	-	
	3,200	11.81	15.63	5.51	8.41	-	16.93	15.63	8.07	8.41	-	19.69	15.63	10.83	8.07	8.41	-	
	3,600	11.81	17.05	5.51	9.11	-	16.93	17.05	8.07	9.11	-	19.69	17.05	10.83	8.07	9.11	-	
	4,000	11.81	18.54	5.51	9.86	-	16.93	18.54	8.07	9.86	-	19.69	18.54	10.83	8.07	9.86	-	
	5,000	11.81	22.48	5.51	11.83	-	16.93	22.48	8.07	11.83	-	19.69	22.48	10.83	8.07	11.83	-	
E3-3	6,000	11.81	30.43	5.51	10.43	10.59	16.93	30.43	8.07	10.43	10.59	19.69	30.43	10.83	8.07	10.43	10.59	

Flanged end is connected to either a transformer or panel. Dimension details are listed below.

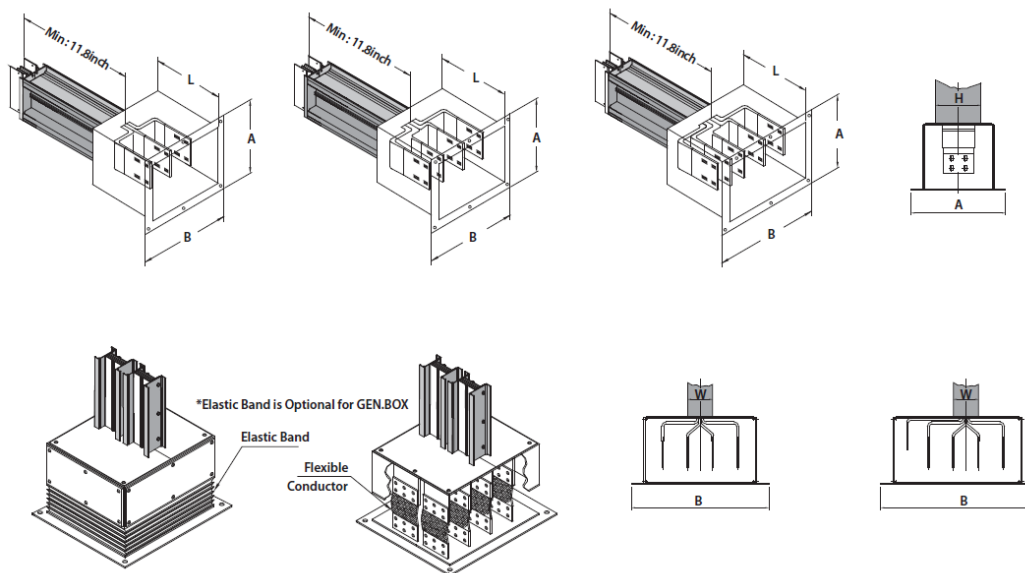

(inch)

Rating (A)		3W Standard Dimension			4W Standard Dimension			4W+50%E, 100%E Standard Dimension		
		A	B	L	A	B	L	A	B	L
AL	630	7.17	14.17	23.62	7.17	19.29	23.62	7.17	22.05	23.62
	800	7.99	14.17	23.62	7.99	19.29	23.62	7.99	22.05	23.62
	1,000	8.94	14.17	23.62	8.94	19.29	23.62	8.94	22.05	23.62
	1,250	9.80	14.17	23.62	9.80	19.29	23.62	9.80	22.05	23.62
	1,600	12.01	14.17	23.62	12.01	19.29	23.62	12.01	22.05	23.62
	2,000	13.82	14.17	23.62	13.82	19.29	23.62	13.82	22.05	23.62
	2,500	19.41	14.17	23.62	19.41	19.29	23.62	19.41	22.05	23.62
	3,200	22.40	14.17	23.62	22.40	19.29	23.62	22.40	22.05	23.62
	3,600	23.98	14.17	23.62	23.98	19.29	23.62	23.98	22.05	23.62
	4,000	26.02	14.17	23.62	26.02	19.29	23.62	26.02	22.05	23.62
CU	5,000	35.16	14.17	23.62	35.16	19.29	23.62	35.16	22.05	23.62
	6,000	38.23	14.17	23.62	38.23	19.29	23.62	38.23	22.05	23.62
	630	7.17	14.17	23.62	7.17	19.29	23.62	7.17	22.05	23.62
	800	7.17	14.17	23.62	7.17	19.29	23.62	7.17	22.05	23.62
	1,000	7.80	14.17	23.62	7.80	19.29	23.62	7.80	22.05	23.62
	1,250	8.43	14.17	23.62	8.43	19.29	23.62	8.43	22.05	23.62
	1,600	9.80	14.17	23.62	9.80	19.29	23.62	9.80	22.05	23.62
	2,000	11.26	14.17	23.62	11.26	19.29	23.62	11.26	22.05	23.62
	2,500	13.23	14.17	23.62	13.23	19.29	23.62	13.23	22.05	23.62
	3,200	17.99	14.17	23.62	17.99	19.29	23.62	17.99	22.05	23.62
3,600	19.41	14.17	23.62	19.41	19.29	23.62	19.41	22.05	23.62	
4,000	20.91	14.17	23.62	20.91	19.29	23.62	20.91	22.05	23.62	
5,000	24.84	14.17	23.62	24.84	19.29	23.62	24.84	22.05	23.62	
6,000	32.80	14.17	23.62	32.80	19.29	23.62	32.80	22.05	23.62	

FLANGED END (MM)

Drilling Pattern for Flanged End

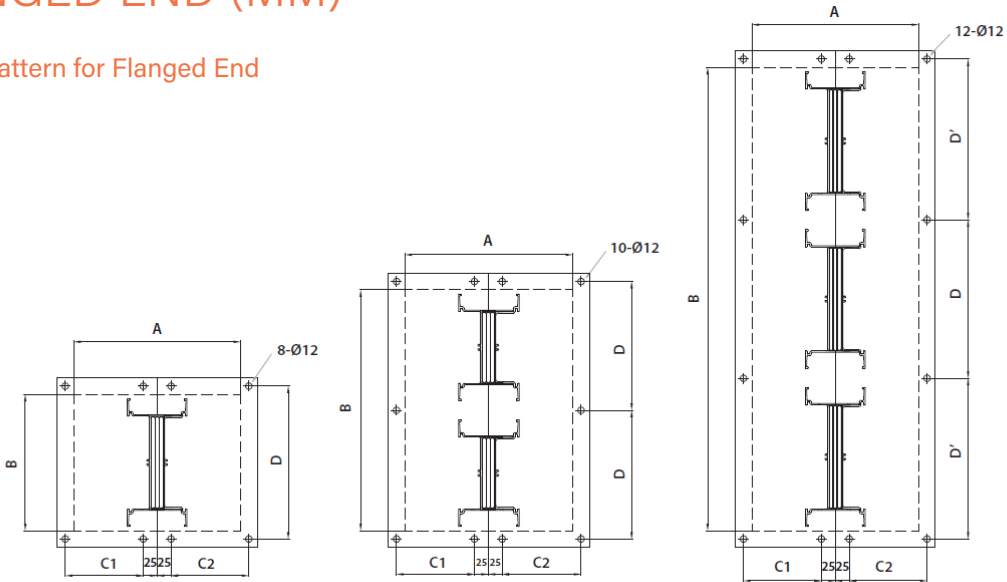

[Fig. E3-1]

[Fig. E3-2]

[Fig. E3-3]

(mm)

Conductor	Rating (A)	3W Standard Dimension					4W Standard Dimension					4W+50%E, 100%E Standard Dimension					Fig.	
		A	B	C1, C2	D	D'	A	B	C1, C2	D	D'	A	B	C1	C2	D		D'
AL	630	240	122	110	152	-	340	122	160	152	-	410	122	230	160	152	-	E3-1
	800	240	143	110	173	-	340	143	160	173	-	410	143	230	160	173	-	
	1,000	240	167	110	197	-	340	167	160	197	-	410	167	230	160	197	-	
	1,250	240	189	110	219	-	340	189	160	219	-	410	189	230	160	219	-	
	1,600	240	245	110	275	-	340	245	160	275	-	410	245	230	160	275	-	
	2,000	240	291	110	321	-	340	291	160	321	-	410	291	230	160	321	-	E3-2
	2,500	300	433	140	231.5	-	430	433	205	231.5	-	500	433	275	205	231.5	-	
	3,200	300	509	140	269.5	-	430	509	205	269.5	-	500	509	275	205	269.5	-	
	3,600	300	549	140	289.5	-	430	549	205	289.5	-	500	549	275	205	289.5	-	
	4,000	300	601	140	315.5	-	430	601	205	315.5	-	500	601	275	205	315.5	-	
	5,000	300	833	140	285	289	430	833	205	285	289	500	833	275	205	285	289	E3-3
	6,000	300	911	140	311	315	430	911	205	311	315	500	911	275	205	311	315	
6,000	300	911	140	311	315	430	911	205	311	315	500	911	275	205	311	315		
CU	630	240	122	110	152	-	340	122	160	152	-	410	122	230	160	152	-	E3-1
	800	240	122	110	152	-	340	122	160	152	-	410	122	230	160	152	-	
	1,000	240	138	110	168	-	340	138	160	168	-	410	138	230	160	168	-	
	1,250	240	154	110	184	-	340	154	160	184	-	410	154	230	160	184	-	
	1,600	240	189	110	219	-	340	189	160	219	-	410	189	230	160	219	-	
	2,000	240	226	110	256	-	340	226	160	256	-	410	226	230	160	256	-	E3-2
	2,500	240	276	110	306	-	340	276	160	306	-	410	276	230	160	306	-	
	3,200	300	397	140	213.5	-	430	397	205	213.5	-	500	397	275	205	213.5	-	
	3,600	300	433	140	231.5	-	430	433	205	231.5	-	500	433	275	205	231.5	-	
	4,000	300	471	140	250.5	-	430	471	205	250.5	-	500	471	275	205	250.5	-	
5,000	300	571	140	300.5	-	430	571	205	300.5	-	500	571	275	205	300.5	-	E3-3	
6,000	300	773	140	265	269	430	773	205	265	269	500	773	275	205	265	269		

Flanged End Box / Feed in Box

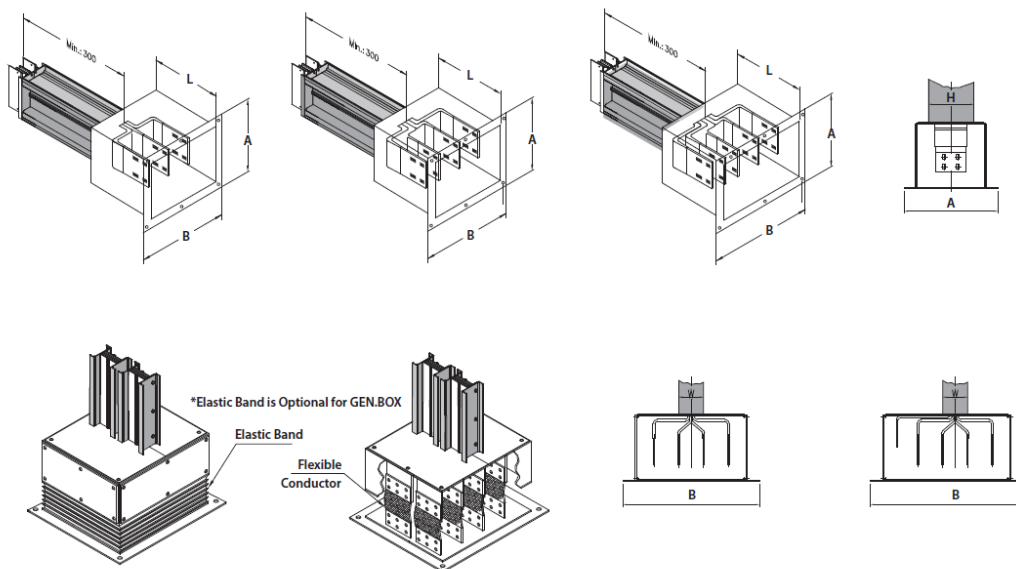

(mm)

Rating (A)		3W Standard Dimension			4W Standard Dimension			4W+50%E, 100%E Standard Dimension		
		A	B	L	A	B	L	A	B	L
AL	630	182	360	600	182	490	600	182	560	600
	800	203	360	600	203	490	600	203	560	600
	1,000	227	360	600	227	490	600	227	560	600
	1,250	249	360	600	249	490	600	249	560	600
	1,600	305	360	600	305	490	600	305	560	600
	2,000	351	360	600	351	490	600	351	560	600
	2,500	493	360	600	493	490	600	493	560	600
	3,200	569	360	600	569	490	600	569	560	600
	3,600	609	360	600	609	490	600	609	560	600
	4,000	661	360	600	661	490	600	661	560	600
CU	5,000	893	360	600	893	490	600	893	560	600
	6,000	971	360	600	971	490	600	971	560	600
	630	182	360	600	182	490	600	182	560	600
	800	182	360	600	182	490	600	182	560	600
	1,000	198	360	600	198	490	600	198	560	600
	1,250	214	360	600	214	490	600	214	560	600
	1,600	249	360	600	249	490	600	249	560	600
	2,000	286	360	600	286	490	600	286	560	600
	2,500	336	360	600	336	490	600	336	560	600
	3,200	457	360	600	457	490	600	457	560	600
3,600	493	360	600	493	490	600	493	560	600	
4,000	531	360	600	531	490	600	531	560	600	
5,000	631	360	600	631	490	600	631	560	600	
6,000	833	360	600	833	490	600	833	560	600	

FITTINGS

Series HP has a wide range of fittings to satisfy any layout configuration. A variety of elbow angles and offsets are available. Fitting designs are shown in the following figures, and they consist of the source-side and the load-side. Offset or combination elbows can be used where standard elbows are not feasible. (Dimensions for each fitting are shown in the following figures. Contact our design team for a minimum dimension.)

* Dimension(inch/mm)

Elbow
[Horizontal]

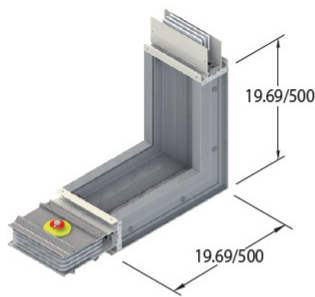

Offset
[Horizontal]

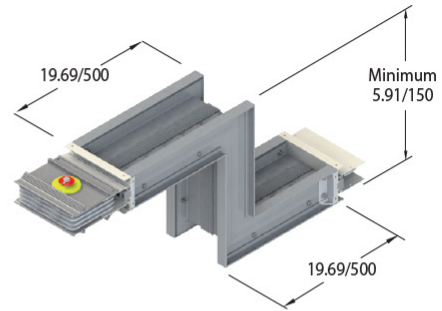

[Vertical]

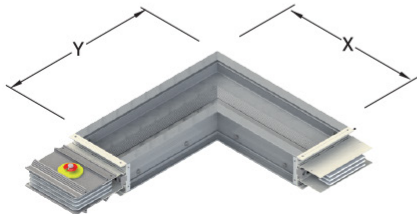

[Vertical]

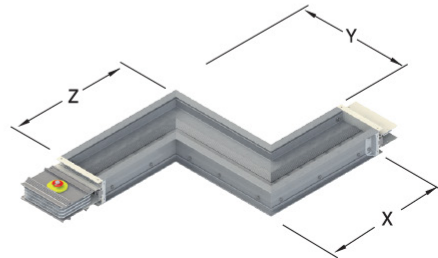

Vertical Elbow

Rating		X		Y	
		inch	mm	inch	mm
AL	630~1,250	19.69	500	19.69	500
	1,600~2,000	23.62	600	23.62	600
	2,500~4,000	27.56	700	27.56	700
	5,000~6,000	35.43	900	35.43	900
CU	630~1,600	19.69	500	19.69	500
	2,000~3,200	23.62	600	23.62	600
	3,600~5,000	27.56	700	27.56	700
	6,000	31.5	800	31.5	800

Vertical Offset

Rating		X		Y		Z	
		inch	mm	inch	mm	inch	mm
AL	630~1,250	19.69	500	5.91	150	19.69	500
	1,600~2,000	23.62	600	5.91	150	23.62	600
	2,500~4,000	27.56	700	5.91	150	27.56	700
	5,000~6,000	35.43	900	5.91	150	35.43	900
	6,000	31.5	800	5.91	150	31.5	800
CU	630~1,600	19.69	500	5.91	150	19.69	500
	2,000~3,200	23.62	600	5.91	150	23.62	600
	3,600~5,000	27.56	700	5.91	150	27.56	700
	6,000	31.5	800	5.91	150	31.5	800

Combination

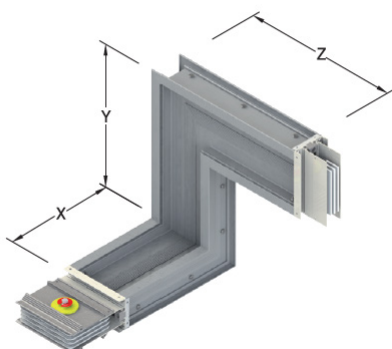

Rating	X		Y		Z		
	inch	mm	inch	mm	inch	mm	
AL	630~1,250	19.69	500	19.69	500	19.69	500
	1,600~2,000	23.62	600	23.62	600	23.62	600
	2,500~4,000	27.56	700	27.56	700	27.56	700
	5,000~6,000	35.43	900	35.43	900	35.43	900
CU	630~1,600	19.69	500	19.69	500	19.69	500
	2,000~3,200	23.62	600	23.62	600	23.62	600
	3,600~5,000	27.56	700	27.56	700	27.56	700
	6,000	31.5	800	31.5	800	31.5	800

Tee

[Horizontal]

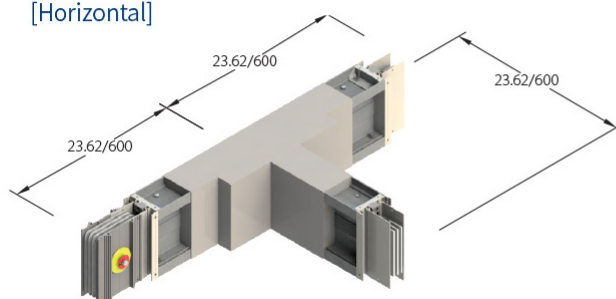

[Vertical]

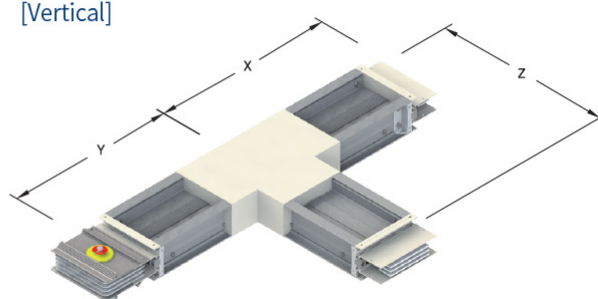

Vertical Tee

Rating	X		Y		Z		
	inch	mm	inch	mm	inch	mm	
AL	630~1,250	19.69	500	19.69	500	19.69	500
	1,600~2,000	23.62	600	23.62	600	23.62	600
	2,500~4,000	27.56	700	27.56	700	27.56	700
	5,000~6,000	35.43	900	35.43	900	35.43	900
CU	630~1,600	19.69	500	19.69	500	19.69	500
	2,000~3,200	23.62	600	23.62	600	23.62	600
	3,600~5,000	27.56	700	27.56	700	27.56	700
	6,000	31.5	800	31.5	800	31.5	800

FITTINGS

Reducer

A reducer is used to connect a large capacity busway to a small capacity busway. It can be used for an economical setup to distribute loads.

*Any change made to load distribution or to capacities follows electricity regulations.

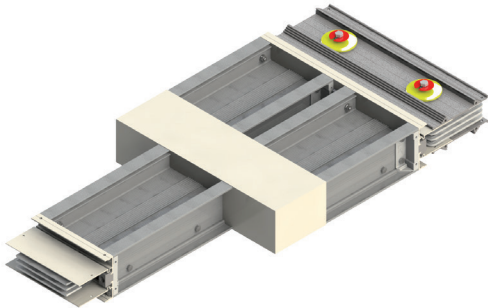

Expansion

The fitting is designed to allow a 60mm extension of a straight line.

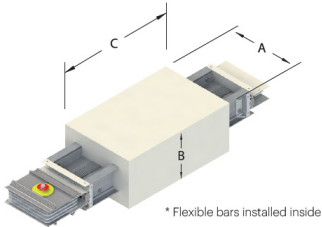

(inch)

Expansion		3W Standard Dimension			4W Standard Dimension			Phase Flexible			Phase Flexible			Earth Flexible Tube		
Conductor	Rating (A)	A	B	C	A	B	C	Each Cross Section (mm ²)	Quantity (EA)	Total Cross Section (mm ²)	Each Cross Section (mm ²)	Quantity (EA)	Total Cross Section (mm ²)	Model	Quantity (EA)	Length
AL	630	12.09	23.62	25.59	12.09	25.98	25.59	16.54	1	16.54	6.69	2	13.39	GSHS-1635F 0.6T x 3"	2	17.72
	800	12.91	23.62	25.59	12.91	25.98	25.59	21.65	1	21.65	6.69	2	13.39		2	17.72
	1000	13.86	23.62	25.59	13.86	25.98	25.59	25.98	1	25.98	6.69	2	13.39		2	17.72
	1250	14.72	23.62	25.59	14.72	25.98	25.59	17.72	2	35.43	6.69	2	13.39		2	17.72
	1600	16.93	23.62	25.59	16.93	25.98	25.59	25.98	2	51.97	12.80	2	25.59		2	17.72
	2000	18.74	23.62	25.59	18.74	25.98	25.59	32.48	2	64.96	12.80	2	25.59		2	17.72
	2500	24.33	23.62	25.59	24.33	25.98	25.59	19.49	4	77.95	12.80	4	51.18		4	17.72
	3200	27.32	23.62	25.59	27.32	25.98	25.59	25.98	4	103.94	12.80	4	51.18		4	17.72
	3600	28.90	23.62	25.59	28.90	25.98	25.59	28.35	4	113.39	12.80	4	51.18		4	17.72
	4000	30.94	23.62	25.59	30.94	25.98	25.59	32.48	4	129.92	12.80	4	51.18		4	17.72
CU	630	12.09	23.62	25.59	33.46	25.98	25.59	16.54	1	16.54	6.69	2	13.39	GSHS-1635F 0.6T x 3"	2	17.72
	800	12.09	23.62	25.59	33.46	25.98	25.59	21.26	1	21.26	6.69	2	13.39		2	17.72
	1000	12.72	23.62	25.59	33.46	25.98	25.59	12.99	2	25.98	6.69	2	13.39		2	17.72
	1250	13.35	23.62	25.59	33.46	25.98	25.59	17.32	2	34.65	6.69	2	13.39		2	17.72
	1600	14.72	23.62	25.59	33.46	25.98	25.59	21.26	2	42.52	12.80	2	25.59		2	17.72
	2000	16.18	23.62	25.59	33.46	25.98	25.59	25.98	2	51.97	12.80	2	25.59		2	17.72
	2500	18.15	23.62	25.59	33.46	25.98	25.59	32.48	2	64.96	12.80	4	51.18		4	17.72
	3200	22.91	23.62	25.59	33.46	25.98	25.59	21.26	4	85.04	12.80	4	51.18		4	17.72
	3600	24.33	23.62	25.59	33.46	25.98	25.59	23.62	4	94.49	12.80	4	51.18		4	17.72
	4000	25.83	23.62	25.59	33.46	25.98	25.59	25.98	4	103.94	12.80	4	51.18		4	17.72
5000	29.76	23.62	25.59	33.46	25.98	25.59	32.48	4	129.92	12.80	4	51.18	4	17.72		
6000	37.72	23.62	25.59	33.46	25.98	25.59	28.35	6	170.08	12.80	4	51.18	4	17.72		

Expansion		3W Standard Dimension			4W Standard Dimension			Phase Flexible			Phase Flexible			Earth Flexible Tube		
Conductor	Rating (A)	A	B	C	A	B	C	Each Cross Section (mm ²)	Quantity (EA)	Total Cross Section (mm ²)	Each Cross Section (mm ²)	Quantity (EA)	Total Cross Section (mm ²)	Model	Quantity (EA)	Length
AL	630	307	600	650	307	660	650	420	1	420	170	2	340	GSHS-1635F 0.6T x 3"	2	450
	800	328	600	650	328	660	650	550	1	550	170	2	340		2	450
	1000	352	600	650	352	660	650	660	1	660	170	2	340		2	450
	1250	374	600	650	374	660	650	450	2	900	170	2	340		2	450
	1600	430	600	650	430	660	650	660	2	1320	325	2	650		2	450
	2000	476	600	650	476	660	650	825	2	1650	325	2	650		2	450
	2500	618	600	650	618	660	650	495	4	1980	325	4	1300		4	450
	3200	694	600	650	694	660	650	660	4	2640	325	4	1300		4	450
	3600	734	600	650	734	660	650	720	4	2880	325	4	1300		4	450
	4000	786	600	650	786	660	650	825	4	3300	325	4	1300		4	450
CU	630	307	600	650	850	660	650	420	1	420	170	2	340	GSHS-1635F 0.6T x 3"	2	450
	800	307	600	650	850	660	650	540	1	540	170	2	340		2	450
	1000	323	600	650	850	660	650	330	2	660	170	2	340		2	450
	1250	339	600	650	850	660	650	440	2	880	170	2	340		2	450
	1600	374	600	650	850	660	650	540	2	1080	325	2	650		2	450
	2000	411	600	650	850	660	650	660	2	1320	325	2	650		2	450
	2500	461	600	650	850	660	650	825	2	1650	325	4	1300		4	450
	3200	582	600	650	850	660	650	540	4	2160	325	4	1300		4	450
	3600	618	600	650	850	660	650	600	4	2400	325	4	1300		4	450
	4000	656	600	650	850	660	650	660	4	2640	325	4	1300		4	450
5000	756	600	650	850	660	650	825	4	3300	325	4	1300	4	450		
6000	958	600	650	850	660	650	720	6	4320	325	4	1300	4	450		

HANGER

Vertical Mounting Hangers

Rigid hangers are used on the lowest floor, and they can be used instead of spring hangers depending on the set up design. Spring hangers are used to support the busway between floors. The number of springs depends on the weight of the installed busway and plug-in unit. Spring hanger's height can be easily adjusted when installed. A medium hanger should be installed if the height between the floors exceeds 15 ft.

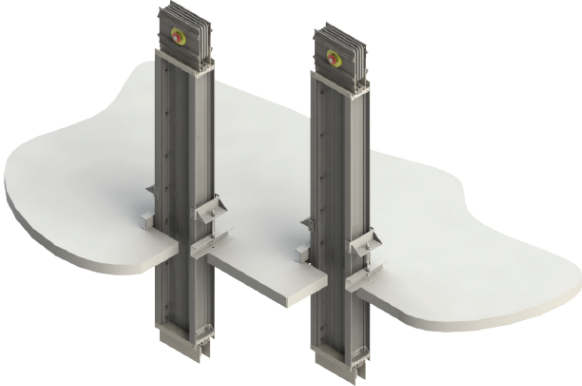

[Rigid Hanger] [Spring Hanger]

Rigid Hanger

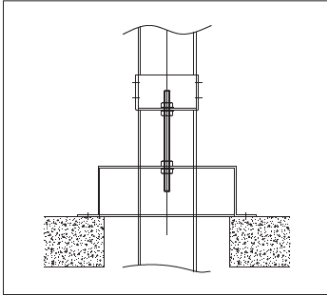

[1 Row]

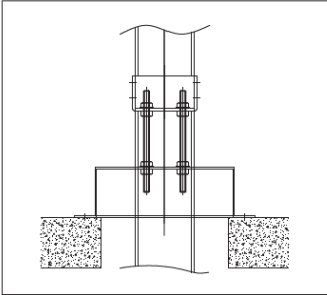

[2 Row]

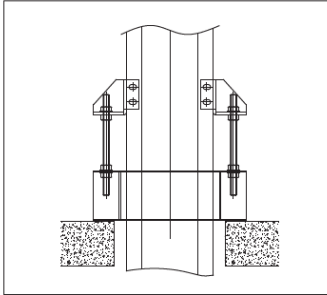

[Side View]

Spring Hanger

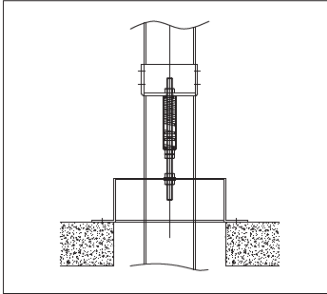

[1 Row]

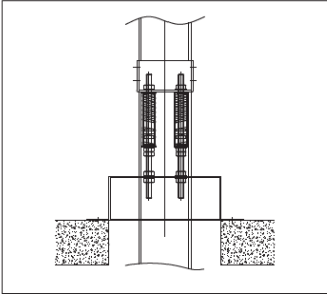

[2 Row]

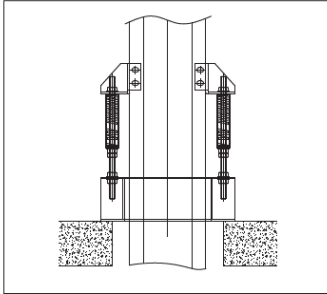

[Side View]

* Hangers with more than 2 rows depending on the installation environment are also available on request. Please contact the design team for further information.

Horizontal Hangers

General Hangers

The standard installation method for these hangers is to install them horizontally at 5ft intervals/1.5 meters. They generally require 0.5inch/12mm diameter stud bolts.

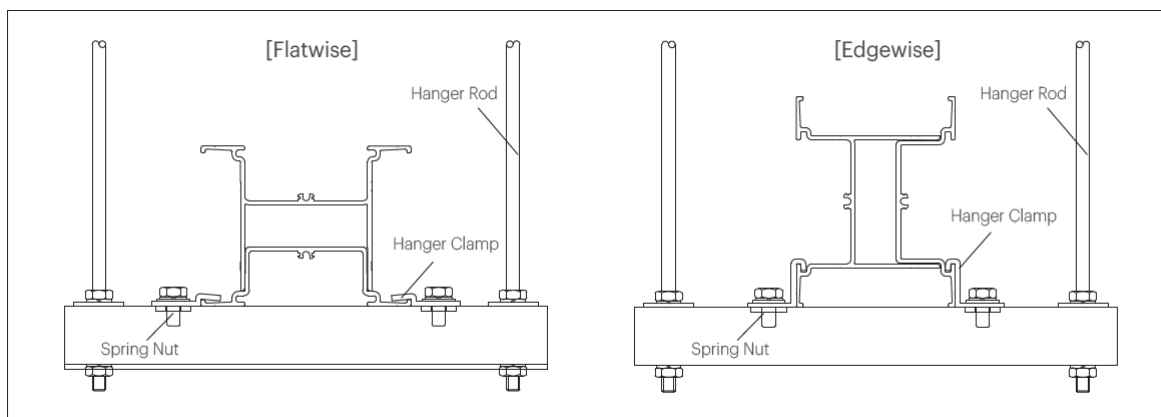

Single drop rod hanger

Single drop rod hangers are available for up to 1600A. It supports the product in flatwise directions on 10ft centers and sway bracing is required. Additional hangers may be necessary depending on the installation site. The contractor must provide the drop rods to assembly for single drop rod hangers.

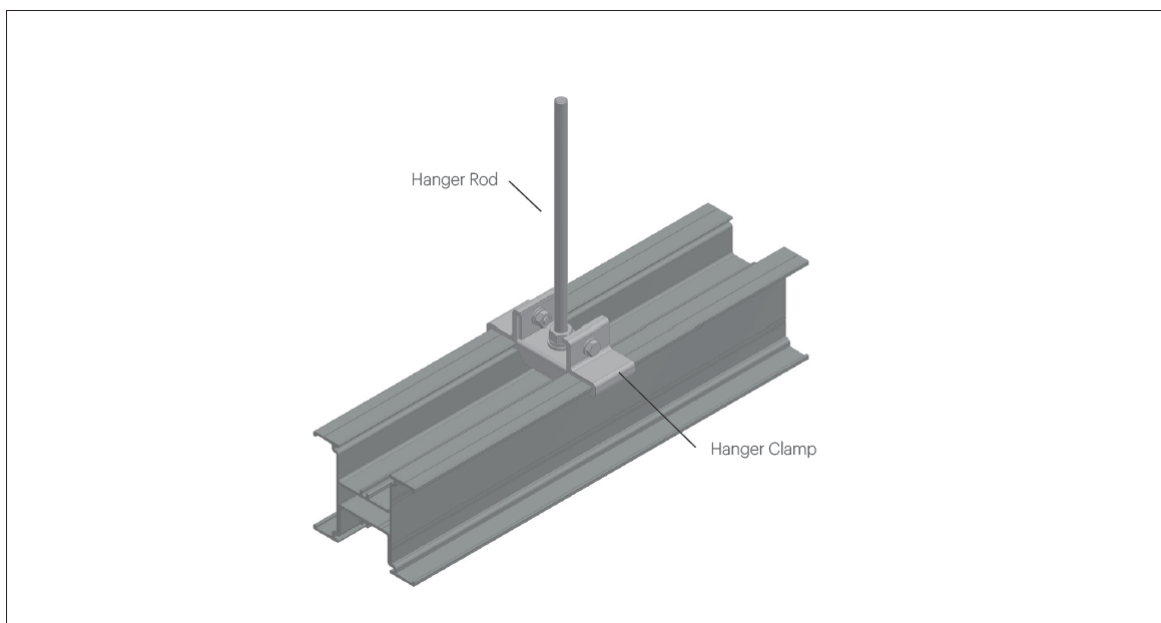

BUS PLUG

Plug-in unit descriptions

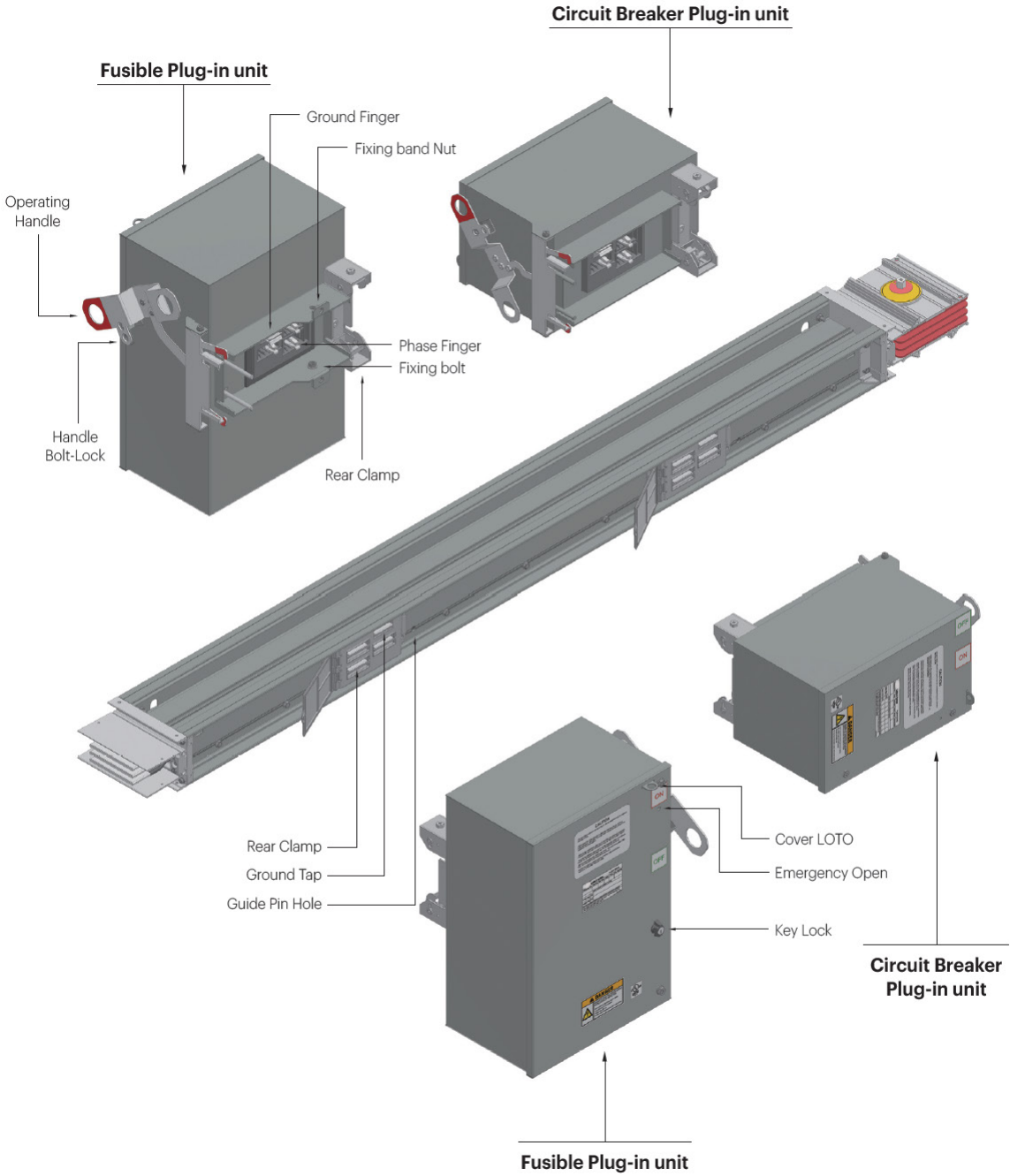

Interlock & Finger safety

Main Device is On status, the bus plug is not separated from the feeder

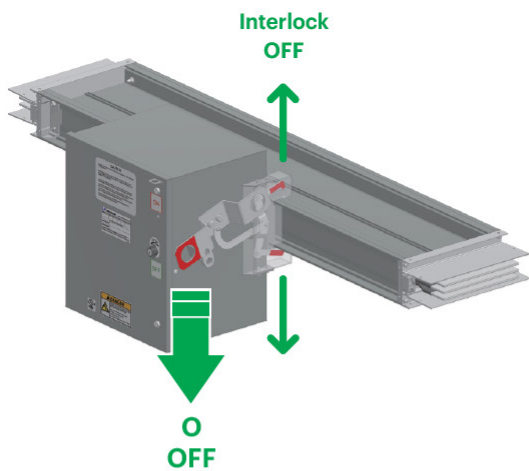

Main Device is On status, the Front door can't open

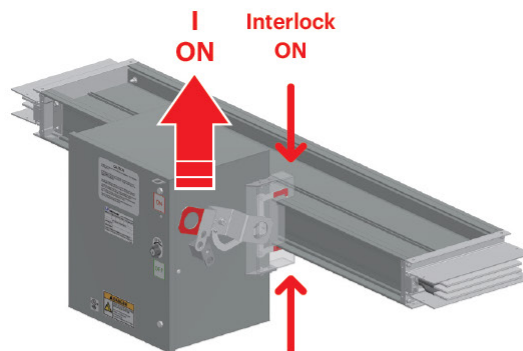

Door Interlock will be released, in case press Emergency Hole

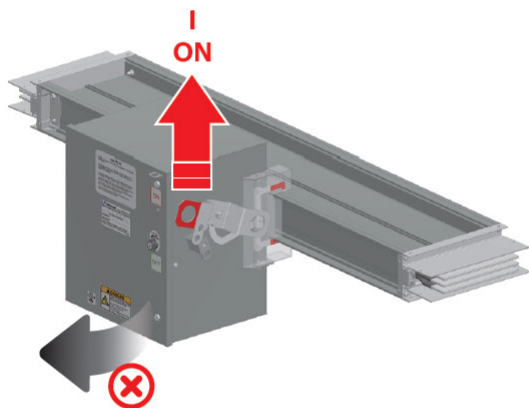

Front door is opened, the Main Device can't On status

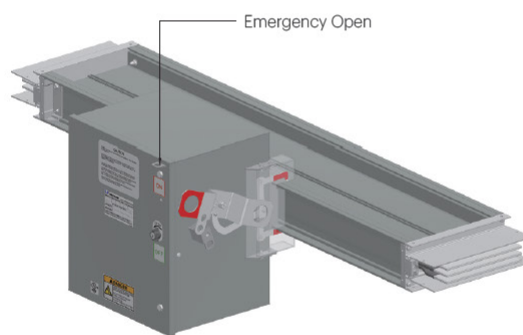

Insulation partition is installed to prevent body access to the primary side

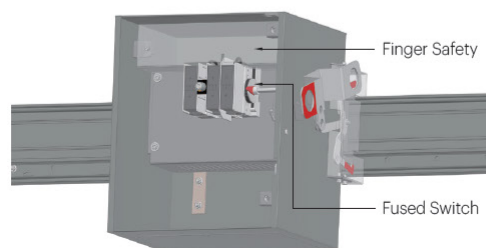
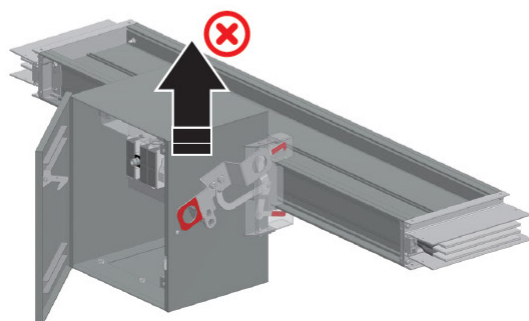

Wall Flange

Wall flange is a product used to close the space between the busway and the wall when penetrating the wall. Glass wool and fire foam is used to fill the wall cavity around the busway. It is not provided by the manufacturer. The standard dimensions of a wall opening should be 1.2inch/30mm larger than the external dimensions of the busway.

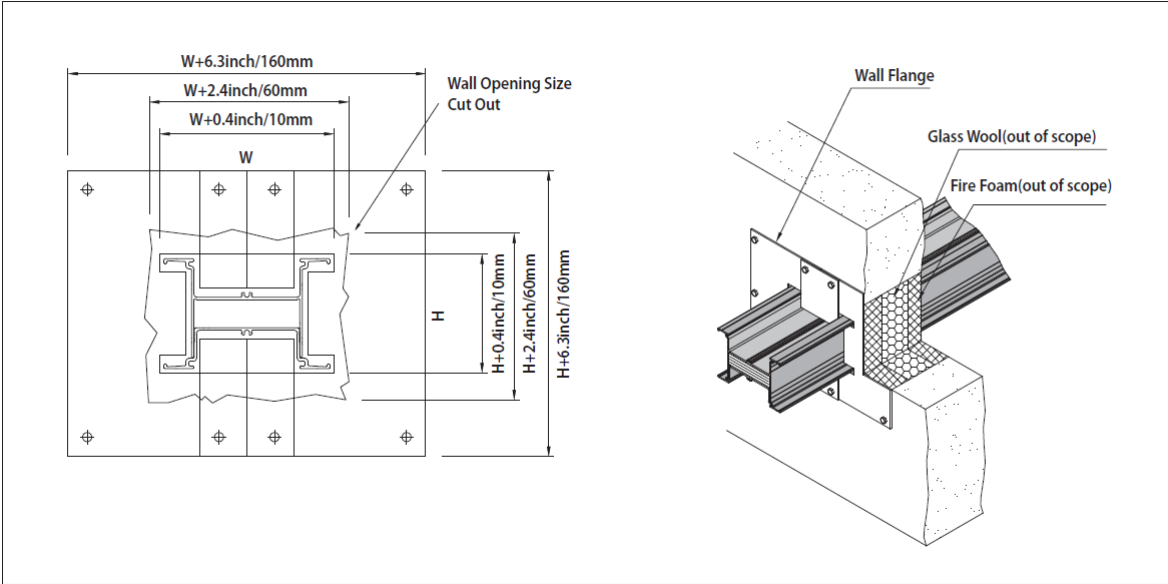

Floor Flange

Floor flange is a product used to close the space between the busway and the floor when penetrating the floor. Glass wool and fire foam are not provided by the manufacturer. The standard dimensions of a floor opening should be 1.2inch/30mm larger than the external dimensions of the busway.

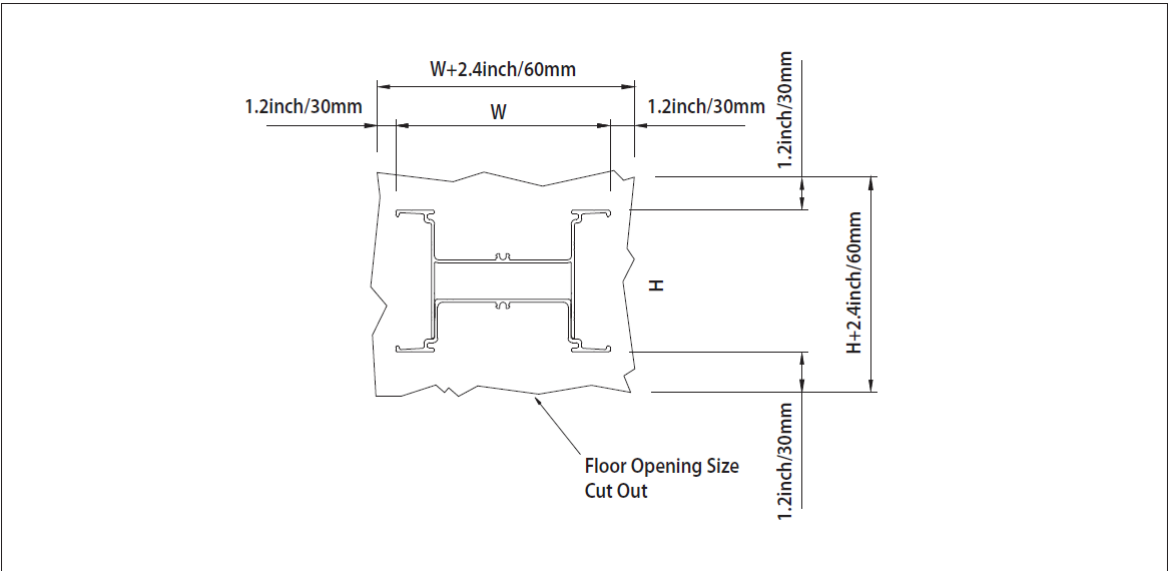

The required minimum distances between a busway and a wall, or a ceiling are shown below.

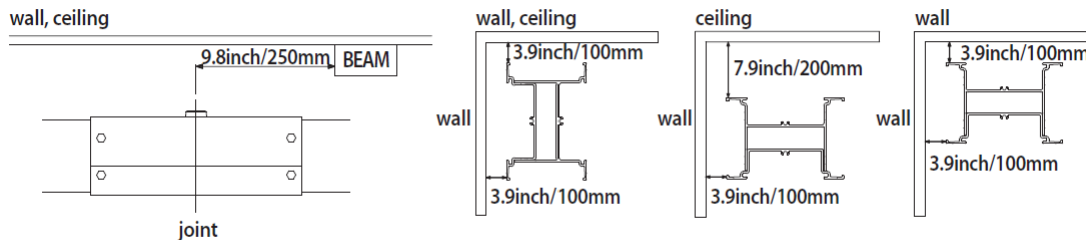

The required minimum distances between busways are shown below.

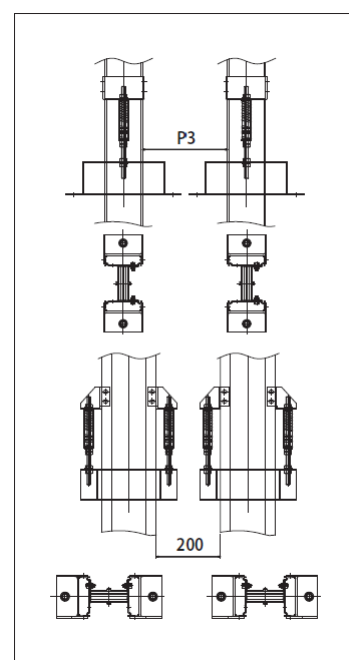
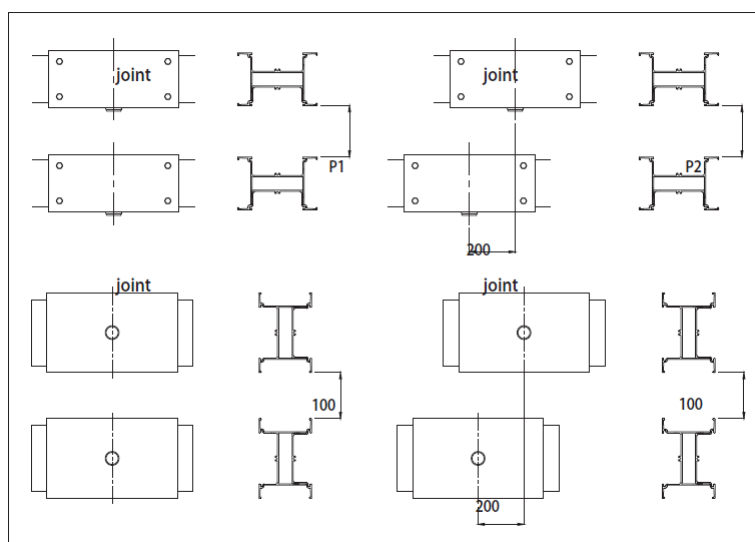

	Standard Dimension					
	3W and 3W		3W and 4W		4W and 4W	
	inch	mm	inch	mm	inch	mm
P1	5.9	150	6.9	175	7.1	180
P2	4.3	110	5.3	135	5.1	130
P3	7.5	190	8.5	215	9.1	230

* Outdoor installation requires further discussion with our design team about proper distance.

TECHNICAL DATA (FT)

Impedance and Voltage Drop

The formula to measure the voltage drop of a busway is shown below. The impedance and voltage drop values for aluminum and copper conductors are shown in the table below. The values listed are measured between upper and middle lines at 60Hz. For a 50Hz installation, multiply the reactance (X) by 0.83.

$$V_d = I \times \sqrt{3} (R \cos\theta + X \sin\theta)$$

V_d = voltage drop[V] · I = rated load amperes[A] · R = resistance[Ω] · X = reactance[Ω] / \cos = power factor / \sin = reactive factor

$$\text{Actual voltage Drop} = \alpha \times V_d \times \frac{\text{Actual load current}}{\text{Rated load current}} \times \frac{\text{Actual length of the line (ft)}}{100\text{ft}}$$

· α (Load Constant) $\alpha = 1$, concentrated load
(a place such as an electrical room)

$\alpha = 0.5$, Distributed load
(a place such as a vertical section)



· F: Flanged End (panel connections)
· P: Plug-in Unit

Ampere(A)	$10^{-5} \Omega/\text{ft} (=10^{-3} \Omega/100\text{ft})(60\text{hz})$			Voltage Drop(/100ft)				
	R	X	Z	0.7	0.8	0.9	1	
AL	630	4.26	1.24	4.44	4.22	4.53	4.77	4.65
	800	2.43	0.80	2.56	3.15	3.36	3.51	3.36
	1,000	2.08	0.67	2.19	3.36	3.59	3.76	3.61
	1,250	1.69	0.55	1.78	3.42	3.65	3.82	3.66
	1,600	1.16	0.37	1.23	3.00	3.21	3.36	3.23
	2,000	0.94	0.30	0.99	3.04	3.24	3.39	3.25
	2,500	0.73	0.24	0.77	2.97	3.17	3.31	3.17
	3,200	0.58	0.19	0.61	2.99	3.19	3.35	3.22
	3,600	0.52	0.17	0.55	3.04	3.25	3.41	3.27
	4,000	0.47	0.15	0.49	3.03	3.23	3.38	3.24
	5,000	0.35	0.11	0.37	2.82	3.01	3.15	3.03
6,000	0.31	0.10	0.33	3.17	3.39	3.54	3.40	
CU	630	2.28	1.24	2.60	2.71	2.81	2.83	2.49
	800	2.28	1.17	2.57	3.37	3.51	3.56	3.16
	1,000	1.67	0.91	1.91	3.15	3.27	3.30	2.90
	1,250	1.34	0.75	1.53	3.18	3.29	3.31	2.90
	1,600	0.94	0.52	1.08	2.87	2.96	2.99	2.62
	2,000	0.73	0.41	0.84	2.80	2.88	2.90	2.54
	2,500	0.57	0.32	0.65	2.70	2.79	2.81	2.46
	3,200	0.47	0.26	0.54	2.85	2.94	2.97	2.61
	3,600	0.41	0.23	0.47	2.80	2.90	2.93	2.57
	4,000	0.37	0.20	0.42	2.78	2.87	2.89	2.53
	5,000	0.28	0.16	0.32	2.69	2.78	2.80	2.45
6,000	0.22	0.12	0.25	2.63	2.72	2.75	2.43	

TECHNICAL DATA (MM)

Impedance and Voltage Drop

The formula to measure the voltage drop of a busway is shown below. The impedance and voltage drop values for aluminum and copper conductors are shown in the table below. The values listed are measured between upper and middle lines at 60Hz. For a 50Hz installation, multiply the reactance (X) by 0.83.

$$V_d = I \times \sqrt{3}(R \cos\theta + X \sin\theta)$$

$$V_d = \text{voltage drop [V]} \cdot I = \text{rated load amperes [A]} \cdot R = \text{resistance}[\Omega] \cdot X = \text{reactance}[\Omega] / \cos = \text{power factor} / \sin = \text{reactive factor}$$

$$\text{Actual voltage Drop} = \alpha \times V_d \times \frac{\text{Actual load current}}{\text{Rated load current}} \times \frac{\text{Actual length of the line (m)}}{100\text{m}}$$

• α (Load Constant) $\alpha = 1$, concentrated load
(a place such as an electrical room)

$\alpha = 0.5$, Distributed load
(a place such as a vertical section)



• F: Flanged End (panel connections)
• P: Plug-in Unit

Ampere(A)	10 ⁻³ Ω/m (=10 ⁻³ Ω /100m) (60hz)			Voltage Drop(/100m)				
	R	X	Z	0.7	0.8	0.9	1	
AL	630	13.98	4.07	14.56	13.85	14.87	15.66	15.25
	800	7.97	2.62	8.39	10.32	11.01	11.52	11.04
	1,000	6.83	2.21	7.18	11.02	11.77	12.32	11.84
	1,250	5.55	1.82	5.84	11.22	11.97	12.52	12.01
	1,600	3.82	1.23	4.02	9.85	10.52	11.02	10.60
	2,000	3.08	1.00	3.24	9.96	10.63	11.12	10.67
	2,500	2.40	0.80	2.53	9.74	10.39	10.86	10.40
	3,200	1.91	0.61	2.00	9.82	10.48	10.98	10.56
	3,600	1.72	0.55	1.81	9.99	10.67	11.18	10.74
	4,000	1.54	0.50	1.62	9.93	10.60	11.09	10.64
	5,000	1.15	0.37	1.21	9.24	9.87	10.34	9.94
6,000	1.02	0.33	1.08	10.41	11.11	11.63	11.16	
CU	630	7.49	4.07	8.53	8.90	9.21	9.30	8.18
	800	7.49	3.84	8.42	11.07	11.50	11.67	10.38
	1,000	5.49	2.99	6.25	10.35	10.72	10.82	9.52
	1,250	4.39	2.45	5.03	10.44	10.78	10.86	9.50
	1,600	3.10	1.71	3.54	9.40	9.72	9.80	8.60
	2,000	2.40	1.35	2.76	9.17	9.46	9.53	8.32
	2,500	1.86	1.05	2.13	8.87	9.16	9.22	8.06
	3,200	1.54	0.85	1.76	9.34	9.66	9.75	8.55
	3,600	1.35	0.74	1.54	9.20	9.51	9.60	8.42
	4,000	1.20	0.67	1.37	9.13	9.42	9.49	8.29
	5,000	0.93	0.52	1.06	8.84	9.13	9.19	8.03
6,000	0.73	0.39	0.83	8.62	8.93	9.02	7.97	

TECHNICAL DATA (FT)

Short Circuit Strength

Series HP has been tested under actual short circuit conditions according to UL 857. The results are shown in the table below.

Feeder

Rating(A)	Al(kA)		Cu(kA)	
	Standard	Option	Standard	Option
630	30	85	35	85
800	30	85	35	85
1,000	65	100	50	100
1,250	65	100	50	100
1,600	65	125	50	125
2,000	85	150	85	150
2,500	125	200	85	150
3,200	125	200	125	200
3,600	125	200	125	200
4,000	125	200	125	200
5,000	125	200	125	200
6,000	125	200	125	200

Bus Plug (MCCB)

MCCB Frame (AF)	Main Device (MCCB)	Short-circuit Rating (rms, kA)		
		240V	480V	600V
100	UTE100	100	65	-
150	UTS150	150	100	50
250	UTS250	150	100	50
400	UTS400	150	100	50
600	UTS600	150	100	50
800	UTS800	150	100	50
1,200	UTS1200	150	100	35

* Above data is for 3 cycles.

1) Maximum 150kA. (Please contact Starline representatives for details)

Bus Plug (Fusible)

Fuse Class	UNIT Frame	Main Device (Disconnect Switch)	Poles	Short Circuit Rating	Max. Horsepower Rating		
	(AF)			rms (kA)	240V	480V	600V
R	30	OT160G03	3	200	40	75	100
	60			200	40	75	100
	100			200	40	75	100
	200	OT200US03		200	75	150	200
	400	OT200US03		200	125	250	350
	600	OT200US03		100	200	450	500
J	30	OS30FAJS30	3	200	7.5	15	20
	60	OS60GJS30		200	15	30	50
	100	OS100GJS30		200	30	60	75
	200	OS200JS30		200	60	125	150
	400	OS400JS30		200	125	250	350
	600	OS600JS30		200	200	400	500
L	800	OS800L12	3	200	250	500	500
	1,200	OS1200L03		200	-	-	-

* Disconnect Switch manufactured by ABB.

JOINT CONNECTION

Joint KIT

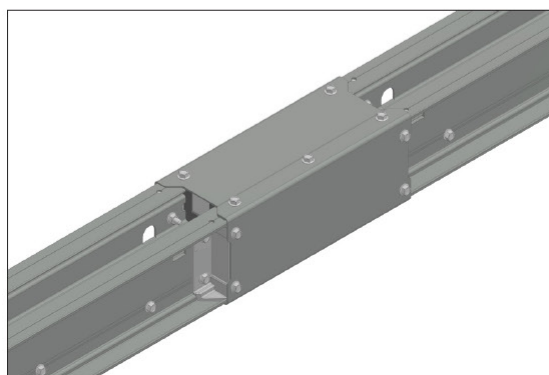
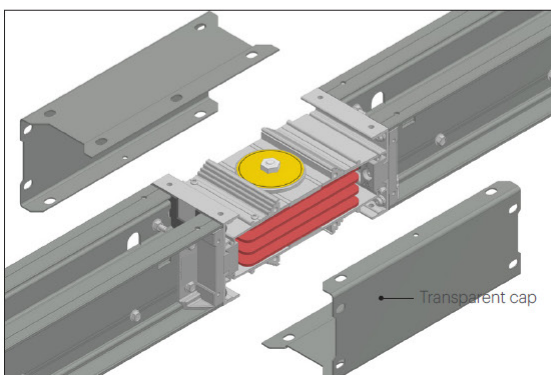
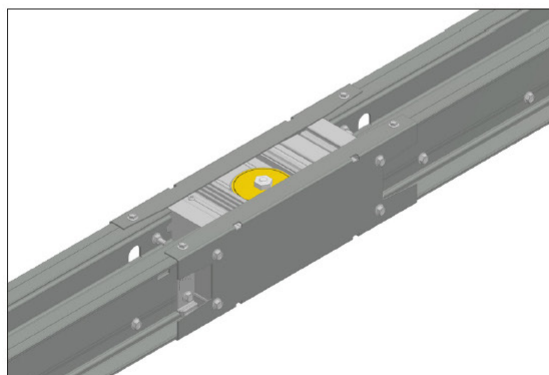
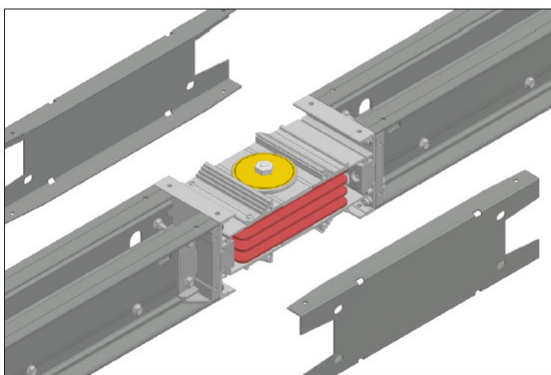
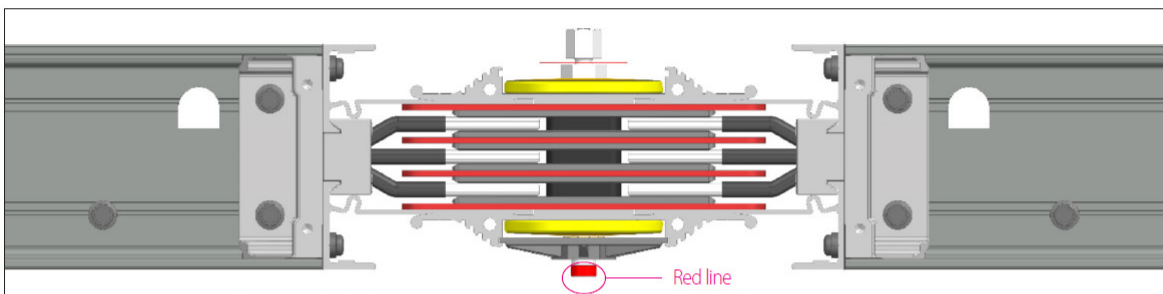
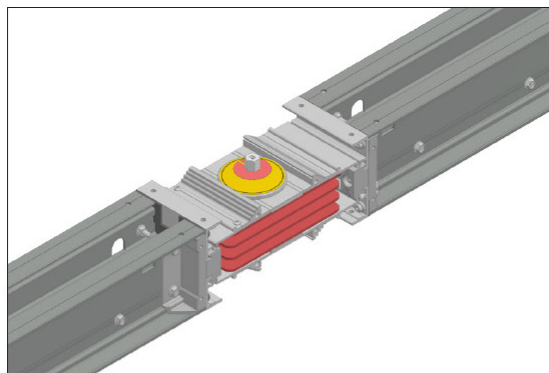
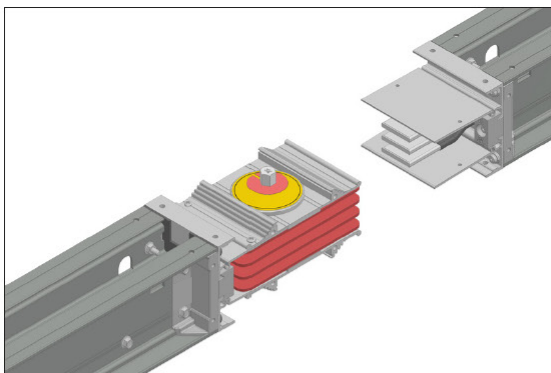

CERTIFICATION & SPECIFICATION



UL Certification

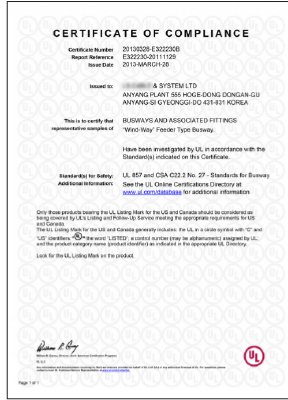

cUL Certification



Seismic Qualification (SEISMIC ZONE 4)



TUV Eco Friendly Certification



ISO 9001



ISO 14001



OHSAS 18001

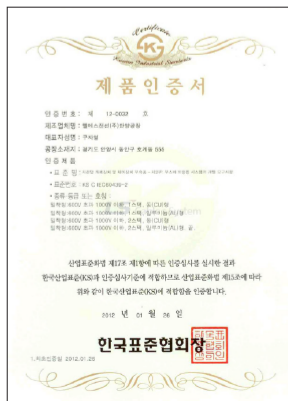

KS Certification

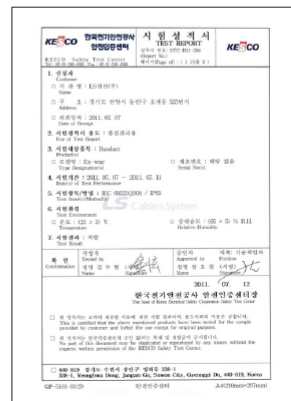

Dust and Water Proof Certification

Starlinepower.com | 724-597-7800

©2024 Legrand. All rights reserved. The industry-leading brands of Approved Networks, Ortronic, Raritan, Server Technology, and Starline empower Legrand's Data, Power & Control to produce innovative solutions for data centers, building networks, and facility infrastructures. Our division designs, manufactures, and markets world-class products for a more productive and sustainable future. The exceptional reliability of our technologies results from decades of proven performance and a dedication to research and development. LIT#2079