

STARLINE SERIES HP

Operation and Maintenance Manual

TABLE OF CONTENTS

SAFETY INFORMATION	3
SUMMARY	4
Scope of application	4
Specification	4
Terms of use	4
Precaution	4
STORAGE AND HANDLING	5
Storage	5
Handling	6
INSTALLATION	7
Check points before installation	7
Supporting busway	8
Fastening the joint part	12
Installation of fittings	15
Bus plugs	19
Others	29
START-UP TEST	31
Check point before energizing	31
Precaution during energizing	31
MAINTENANCE	32
General maintenance work	32
Expansion of branch	32
Expansion and replacement of busway line.	33

SAFETY INFORMATION

GENERAL INFORMATION AND WORKER SAFETY

This manual contains important contents that must be observed in order to prevent accidents and to guarantee the quality of products and systems during installation. Each item includes worker safety considerations, as indicated by a danger warning symbol. Precautions for each item are classified by severity level, as outlined below.



Immediate hazardous situations, without proper precautions, may result in death or serious injury.



Potential dangerous situations, without proper precautions, could lead to death or serious injury.



Potential hazardous situations, and without proper precautions, possible physical damage to equipment.



These instructions and precautions are designed to the user avoid dangerous situations. Failure to take proper precautions may result in unintended consequences.

If more than one warning occurs, it is considered to be a higher risk situation.

GENERAL INFORMATION AND INSTALLATION MANUAL PRECAUTIONS

This manual contains precautions and instructions for the installation of Starline Series HP. Please note that this product is strictly differentiated from other companies' products, other power equipment, or other models produced by us, and its use is restricted.

While we have attempted to cover as much of the product and site as possible, please be aware that this manual is not intended to cover the full range of on-site changes. Therefore, we cannot guarantee the quality of the products and construction for any situation that may occur at the construction site.

This manual is periodically revised through careful review of construction sites and products. If you require additional information or changes, please contact Starline Holdings, LLC, and we will promptly revise the manual.

To ensure the quality of the busway system, it is crucial to follow a series of careful installation, operation, and maintenance procedures, starting from product transport, storage, handling, installation, and inspection. As a large-capacity, heavy-weight product, it can be challenging to secure the quality of busway when installed by untrained non-experts. Therefore, installation must be performed by qualified technicians who are well-informed about this manual. Please exercise caution and ensure that the engineer has thoroughly reviewed this manual before installation.

SUMMARY

This manual includes installation, commissioning, operation, testing and maintenance of Starline Series HP. The purpose of this manual is to prevent the occurrence of safety accidents and product degradation by improper installation.

1.1 SCOPE OF APPLICATION

This operation manual is limited to Series HP, a sandwich type LV busway and system components, including feed units, plug-in units and accessories. The system is rated for 1000 Volts AC or less, and a 630 - 6000 Amps.

1.2 SPECIFICATION

- IEC 61439-1, 6
- UL 857
- KS C 8450
- NEMA BU 1.1
- NEC C37.23
- AS / NZS 3439.2

1.3 TERMS OF USE

1.3.1 Ambient temperature

- -5 ~ 40 °C (23~104 °F)

1.3.2 Altitude

- Below sea level 2,000m (6,600 feet)

* Consult your local Starline Representative if your environment does not meet the product's storage, handling, or installation requirements or terms of use.

1.4 PRECAUTION

- Before installation, please confirm transportation, storage and handling matters.
- Please wear safety equipment such as safety helmets, safety goggles, insulated gloves, and safety shoes at the time of construction and be sure to apply them under the supervision of the safety manager.
- Successful busway operation requires proper product handling, construction and maintenance as well as proper product design and production. Ignoring basic construction and maintenance items can lead to fatal personnel accidents or damage to the product.
- The installation of busway system must be carried out by a qualified technician. It should be constructed by a person who is knowledgeable about electrical power equipment, best safety practices, and product installation processes.

STORAGE AND HANDLING

Handle and store the materials with care to avoid potentially damaging the inside and outside of the product. Before construction work, it is necessary to remove the elements that may affect the quality of the product and safely handle and store it.

2.1 STORAGE

Busway system components should be stored in a clean and dry room while awaiting installation. This also applies to busway systems that have been installed but have not yet been energized. In particular, the busway should not be stored outdoors. Even if it is an outdoor type product, you must keep it indoors because its performance cannot be exhibited until the installation is completed.

1. The storage of the product must comply with the following:
 - Keep on flat and stable surface and avoid inclined space.
 - Store in a place that is dry and not at risk of becoming wet or submersed.
 - Store in a place with consistent temperature and air circulation. Rapid changes in temperature may cause condensation to occur, which is to be avoided.
 - Keep in a place free from dust, welding spark, contaminants and any vibration.
2. For long-term storage or products that cannot be installed immediately, keep the product stored in factory packaging. If you put other weight on the upper part of the packing or keep other products in a stack, there is a risk of damage to the product. If it is stored for more than 3 months, moisture absorbent should be replaced and plating condition should be checked.
3. When disassembling the packing, please use

wooden block as shown below. Please protect it with vinyl etc. for each since there is a risk of penetration of dust or foreign matter into the connection part or joint kit. In particular, it should not be stored in a damp place on a floor without support or leaned against a wall.

4. When storing the PH BOX, keep the brush (electrical contact part) in a place protected from foreign matter and moisture, and store it separately. The spring tension of the brush is an important part of the product quality. Be careful not to cause physical deformation as it leads to an accident.
5. Please be careful not to put elbows and other fitting materials in two stages by default. Take care when storing the flanged end since it is connected to other electric power devices (TR, ACB, ATS, GENERATOR, ..) and the conductor of the flanged end is exposed to the outside. Physical deformation and contamination of electrical connection can increase the contact resistance and lead to heat or accidents.

NOTICE

in the factory shipment state until the product is installed. Avoid places where physical impact or external force is constantly being kept during product storage, especially in areas where there is risk of condensation or flooding.

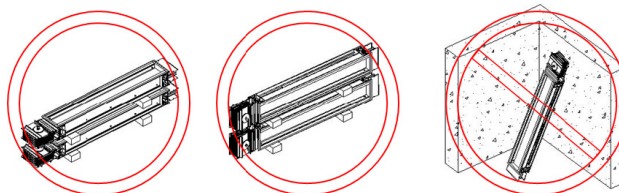

HANDLING AND STORAGE

2.2 HANDLING

Be careful when transporting or handling heavy objects as this may cause injury or damage to the product. Excessive impact, distortion, and rough handling may result in damage to the enclosure or internal insulation of the product.

1. Please check the attached documents such as packing list and product contents when you receive the product.
2. When disassembling, please remove band by using a band cutter. In case of wooden packing, use nail puller to remove the package and be careful not to damage the product..
3. Please check the condition of the contents after unpacking. During transport, please check if moisture and corrosion are caused by physical damage and condensation.
4. Please check the catalog of the product and check the weight of each product. There is a risk of injury during transportation and handling of the product. For safety, the maximum allowable load of the transportation and construction equipment should be compared with the weight of the product and appropriate equipment should be used.
5. When installing in high places with manual or automatic platform lift, please fix it firmly and install it after confirming it does not move.
6. When transporting goods by hoist, forklift or crane, it is necessary to check the weight of the product, select appropriate equipment, transport it, and balance it so that it does not tilt. Use nylon strip when transporting by hoist or crane. Especially, be careful not to damage the product when using metallic cable or wire.
7. Do not use the busway end (connection parts or joint kit) when transporting or stacking. Do not use excessive force.
8. Do not drag the enclosure or connections onto the floor.

WARNING

- Failure to firmly support the product during handling or shipping may result in serious accidents, such as falling.
- It must be handled and transported in compliance with safety regulations. The product should be firmly fixed, handled and transported in a stable place.
- Never transport the product by supporting connection parts.

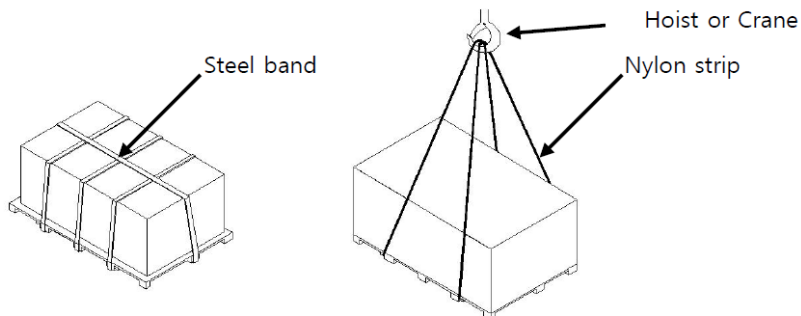

Figure 2. Handling

INSTALLATION

NOTICE

Before construction, check the risk factors and make a construction plan carefully. All components of the busway must be stored and handled in a dry and clean environment until the construction is completed and energized.

3.1 CHECK POINTS BEFORE INSTALLATION

1. Check the BOM (Bill of Material) at the time of receipt of the product to confirm the products in the construction section. Also, please confirm that there is no damage during transportation and storage.
2. busway construction should be installed according to the approved drawings. Before installation, check the layout of the whole system; the TR/switchboard, phase arrangement, enclosure size must be confirmed on the approval drawings.
3. Confirm the product on the approved drawing and the actual product to be installed. Please confirm the products such as feeder, PH feeder and various fittings to be installed in the corresponding position with the approval drawing.
4. Be sure to install insulation resistance, phase sequence and each phase/earth conductor continuity before installation. The product is shipped after factory inspections for insulation resistance, appearance, and withstand voltage test. However, since it may be damaged or destroyed during shipping, handling and storage, be sure to check the insulation resistance, phase sequence and each phase/earth conductor continuity of each product before installation (Refer to page 31). The surface of the joint conductor should be checked for foreign matter which should be removed.
5. If the installation period is longer than one day, the insulation resistance of the installed line before/ after its installation must be checked on a daily basis. There is always a possibility of damage due to environmental factors or other process of the line being installed. Please check insulation resistance of each line as well as each product.
6. The busway system must be protected from moisture, submersion and other contaminants during construction or use. These include:
 - Indoor busway must be protected from moisture and submersion during/after installation. In addition, there is a risk of condensation inside and outside the busway due to the temperature change of the building under construction. Therefore, the product should be protected to prevent condensation. It is ideal to install after the wall and ceiling finish because there is a risk of submersion and dew condensation, especially when installing the riser parts in the condition that the wall finishing or the upper ceiling finishing is not completed. When installing riser parts, install waterproof jaws in preparation for busway.
 - Be mindful of the way outdoor type busway is handled and stored, as the system is not outdoor rated until the system installation is complete.
 - Install the product at a distance from the pipe where there is a risk of leakage during installation. In particular, be careful when installing the product in close proximity to a cooling pipe or a ventilation duct that emits cold air, which may cause condensation.
 - When installing outdoors, install it away from the floor or roof. If the busway is covered with snow during winter season, condensation or submersion may occur.

INSTALLATION

3.2 SUPPORTING BUSWAY

Busway is generally supported by stud bolt, system channel, angle, channel etc. on building (ceiling, floor, wall, beam). It should be installed at a sufficient distance from the ceiling and walls in order to secure adequate heat dissipation space as well as install the joint cover while supporting busway and disassemble/reassemble for maintenance. In particular, it should not be installed behind distribution boards or switchboards (Refer to NEC Article 364). The recommended minimum clearance between the busway ends should be maintained at least 100 mm(3.94 in.) to allow for the removal and assembly of the joint cover.

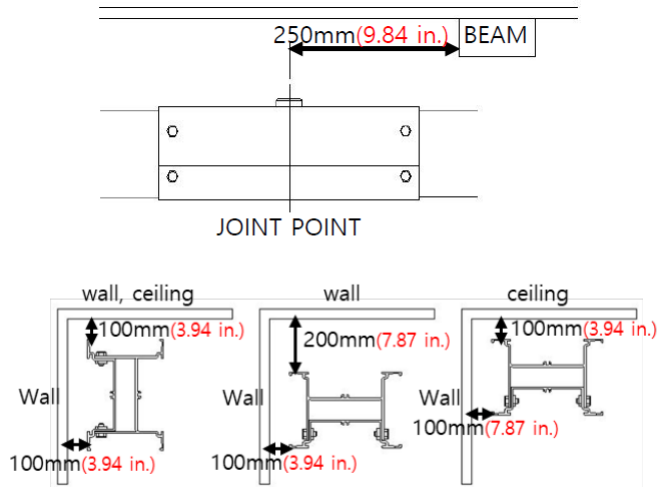

The required minimum distances between busways.

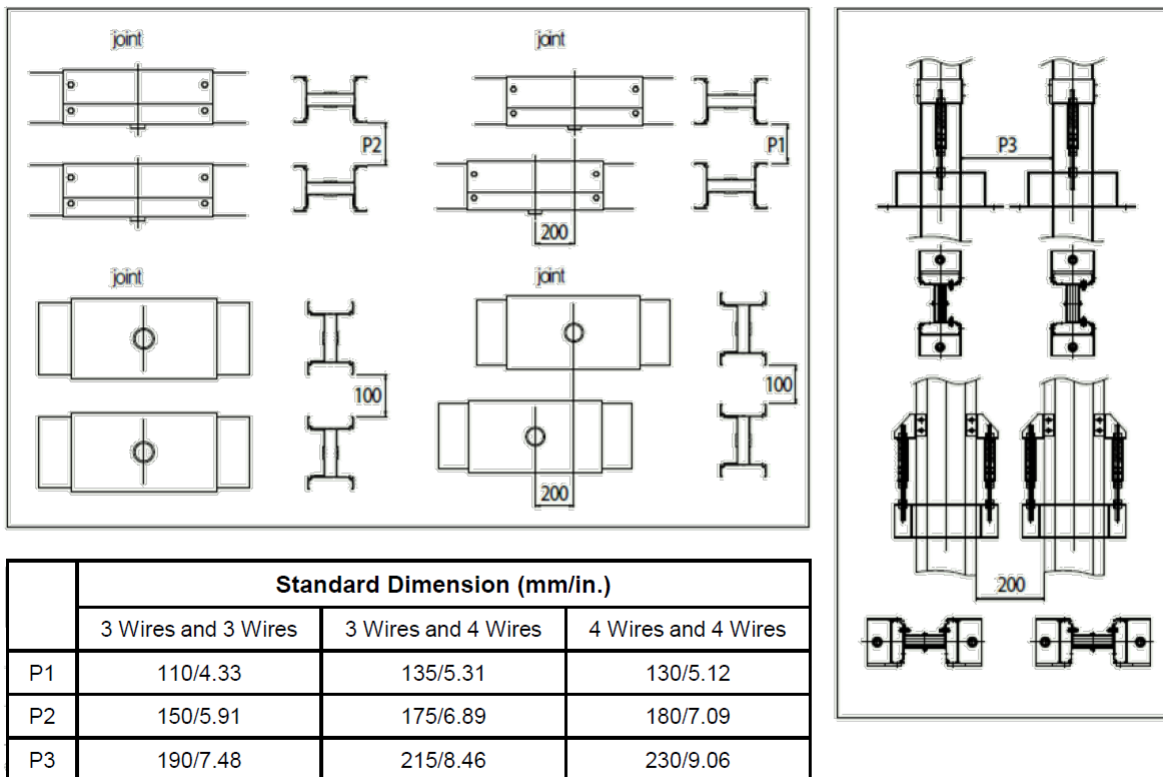

Figure 3. Minimum Installation Distances

INSTALLATION

3.2.1 HORIZONTAL PART SUPPORT

The installation of the horizontal part is generally carried out in the following order.

1. Support hanger rod to ceilings or other safe structures. (It should be reviewed and installed by an expert if section shape steel like System Channel, Angles are used instead of Hanger rod.)
2. Make sure that the building structure is capable of supporting the entire busway system.
3. Install Hanger bar.
4. Put the busway on the hanger bar and adjust the final installation position.
5. Install joint kit and joint cover.
6. Install Hanger clamp after installation is finished. (Direction of busway installation should be checked. Hanger clamp is different for edgewise/flatwise installation.)

Single Drop Rod Hanger Installation

- Single drop rod hangers are available for up to AL 1600A in the flatwise direction.
- Sway bracing is required every 30 feet. Additional hangers may be necessary depending on the installation site. The contractor must provide the drop rods to assembly for single drop rod hangers.

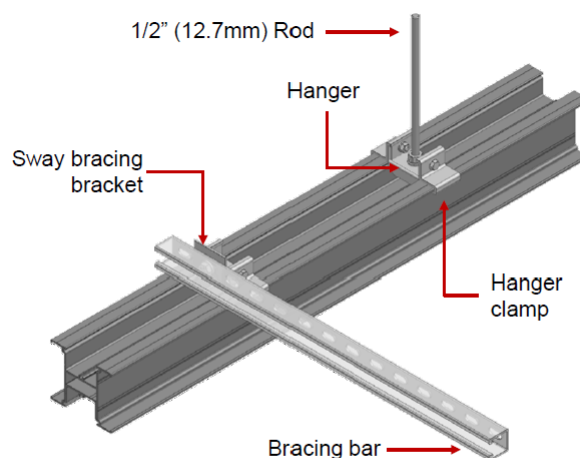

Figure 5. Single Drop Rod

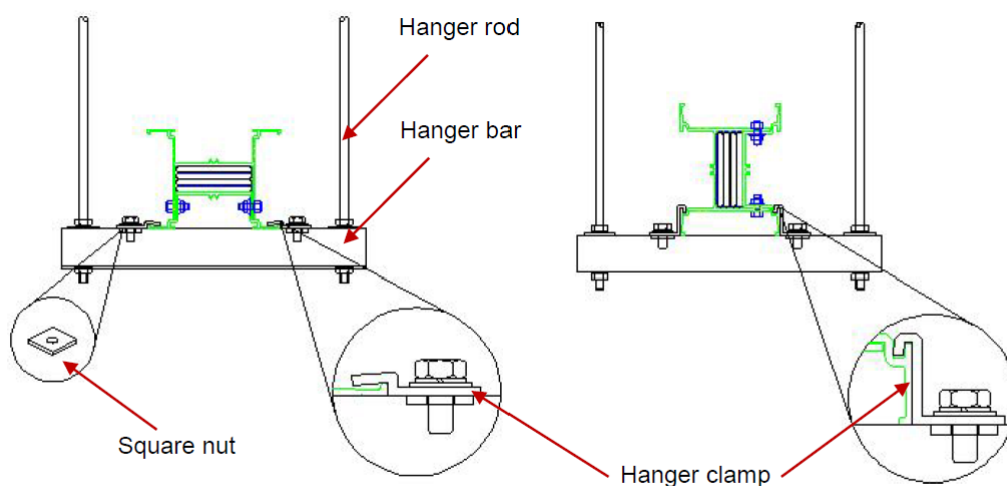

Figure 4. Trapeze Hanger

INSTALLATION

When working on the full-thread bolt with the anchor bolt on the ceiling or the wall, be aware of the following:

1. Clarify the installation position of the busway before installation and specify the full thread bolt support point. Also check whether it is flat-wise or edge-wise installation and the busway rating beforehand.
2. Make sure that the busway is installed with firm support.
3. Each busway should be supported in two places in order to ensure the stability of installation.
4. The supporting point and the center of the joint should be separated by at least 200mm(7.87 in.). Damage to the joint cover may occur when supporting on the joint part, and it is difficult to disassemble the joint cover at a later inspection.
5. When bolting the anchor on the ceiling or the beam, each support must withstand at least the weight of the product plus 90 kg(198.4lb). (IEC 61439-1,6)

6. The supporting distance of the hanger should be within 1.5m(5ft). In case of support exceeding 1.5m(5ft) due to the site conditions, supporting should be carried out according to the weight of busway and support material.
7. If it is difficult to support on the ceiling, the wall bracket can be used and supported from the wall side. However, it should be possible to install a hanger clamp, and the weight and the interval of support should be carried out on the same basis.

⚠ WARNING

- Because the product is installed mainly in a high position, it is necessary to strictly observe the safety precautions to avoid personnel accidents or damage to the product.
- Please review the approved drawing carefully before the installation to check whether there is interference with the busway route and other facilities such as the ventilation ducts and the pipe, etc.
- Be sure to read the manual before the installation and make sure that various parameters in the construction site are checked and installed by experts.

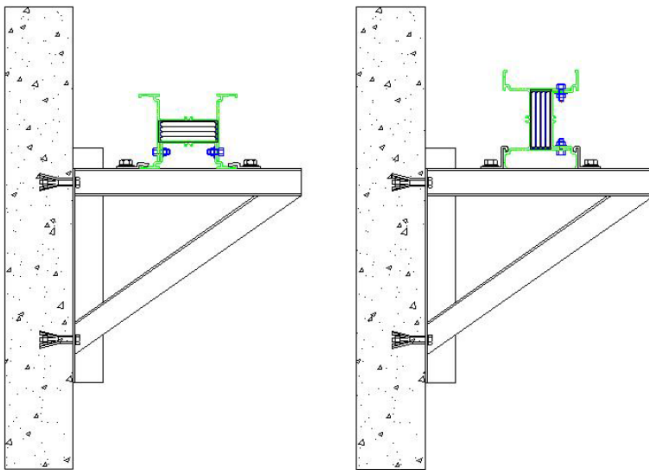

Figure 6. Wall Hanger

INSTALLATION

3.2.2. VERTICAL PART SUPPORT

The basic supporting brackets are the spring hanger and the rigid hanger when installing the vertical section, and the installation standard is according to the vertical section installation standard. Please refer to Attachment #1 on the last page of the manual.

The spring hanger supports the weight of the busway in each floor using the compressive restoring force of the spring. The compression of the spring is set at the factory at the time of shipment, however, when the site changes, adjust the spring compression strength according to the detail of the construction.

⚠ CAUTION

- When spring hanger is shipped from the factory, the weight of the floor and the busway system at the bottom is pre-set considering the system. Removing or loosening the upper red nut of the spring hanger to accommodate the product will not support the layer properly because the pre-set compressive strength is weakened.
- It should not be removed during construction. After installation, check the line and remove the red nut.
- When a vertical granular section is installed, it is necessary to adjust the vertical angle between the layers. When positioning or installing the base channel, install it so that it does not bend or twist depending on the vertical direction of the upper and lower layers.

The installation of the vertical part of is generally carried out in the following order:

1. Set the base channel installation position according to vertical and horizontal level.
2. Display anchoring point on the bottom of each floor. (Use base channel bottom hole as template).

3. Drill the anchor hole on the floor, install base channel after installing anchor. Fix the base channel firmly so it does not move.
4. Rigid hanger or spring hanger is attached to the product. Confirm the correct serial number and allocate it to the floor.
5. Remove the nut on the bottom and place it on the base channel. The difference between the building drawing and the actual drawing and the actual production dimension is adjusted by adjusting the nut.
6. When installing the vertical part, it is easier to install the floor by pushing the product from the upper floor through floor opening, so that the work can be carried out by one team in two groups.
7. When connecting the final connection, check the horizontal and vertical directions to prevent warping and twisting.
8. After installing and inspecting the whole vertical part, remove the red nut on the upper part of the spring hanger to absorb vibration, external impact, and busway deformation due to thermal expansion.
9. When installing the vertical part, the standard is to install Medium Hanger at over 4.5m(14.8 ft) and to install wall bracket at over 6m(19.7 ft) layer. Medium Hanger can be installed by installing Medium Hanger in the floor height of 4.5m(14.8 ft) or less according to the situation of the site or busway capacity, but it is required to be included in the preliminary specification, and it can be constructed according to UL857 regulations according to customer's request.

(Note) Among international regulations related to busway construction

- NEMA BU1.1: If the floor height is more than 16 feet, additional support construction is required.
- UL 857: If the floor height is more than 3.5m(11.5 ft), additional support structure construction is required.

INSTALLATION

3.3 FASTENING THE JOINT PART

3.3.1 Fastening the joint kit

It is the most important factor to guarantee the performance of busway system as it is an electrical connection part. It should be installed with the utmost care during construction.

⚠ WARNING

- Be sure to keep it in dry and clean room.
- Make sure that the entire connection surface before installation is clean and protected from dust, moisture, and other contaminants.

Installation of the joint kit of the joint part is generally carried out as follows:

1. Remove the packing and debris in joint parts.
2. The M12 double-head bolt is tightened with 300~400 kgf cm (29.42~39.43 N m) torque at the factory to prevent the product from the damage during transportation. Loosen the double-head bolt by counter clockwise before assembly.
3. Careful alignment is necessary both vertically and horizontally. Push both ends of the product up to the point where the distance between the enclosures is 250mm(9.84 in.). Be careful not to scratch the connector or subject it to unreasonable impact.
4. The tolerance error of the joint part is $\pm 2\text{mm}$ (78.7 mil) so that the joint cover can be fastened.

5. Slowly tighten the outer head of the double head bolt with a wrench. The outer head of the double head bolt is designed to break at 800~1000 kgf·cm (78.45~98.07 N·m), so slowly tighten the outer head until it breaks.
6. After the outer head is broken and separated, the red tag will fall off and the proper connection of the joint part can be visually confirmed.
7. Confirm the proper distance between the enclosure and the joint kit after finishing the connection. Confirm that the connection between the conductors is done properly without gap. (Check if there is a gap between the conductor by gap gage).
8. Separated red tags should be kept by location and submitted at the final inspection.
9. When installing the final joint cover, make sure that the distance between the end block of the product and the hole of the connection cover is correct.

⚠ WARNING

- When reinstalling by line change during construction, or when changing line after completion of installation, be sure to replace double head bolt or use torque wrench to secure proper fastening force of joint part.

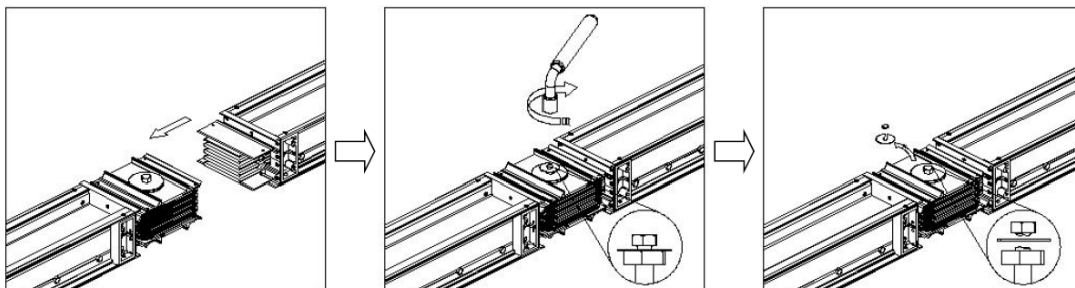

Figure 7. Joint Part

INSTALLATION

When installing the joint kit on the side, top and bottom:

It is possible to install the product on the side when the installation space is narrow or the product is horizontally aligned due to the site condition and construction is impossible. In this case, the joint kit can be attached to or detached from the product. In both cases, make sure that the product does not tilt horizontally and vertically, and that the product is properly aligned with the center.

In particular, if the joint kit is detached from the product and pushed side-by-side, excessive shock may cause damage to the kit's internal components.

* When inserting the joint kit, the distance between the ends of the enclosure should be 250mm(9.84 in.) or more as shown in the figure below. Especially when installing more than 2 stacks, be sure to secure at least 250mm (9.84 in.) apart.

* Be careful not to align the joint kit excessively and shock the joint kit. Otherwise, the insulation may be destroyed.

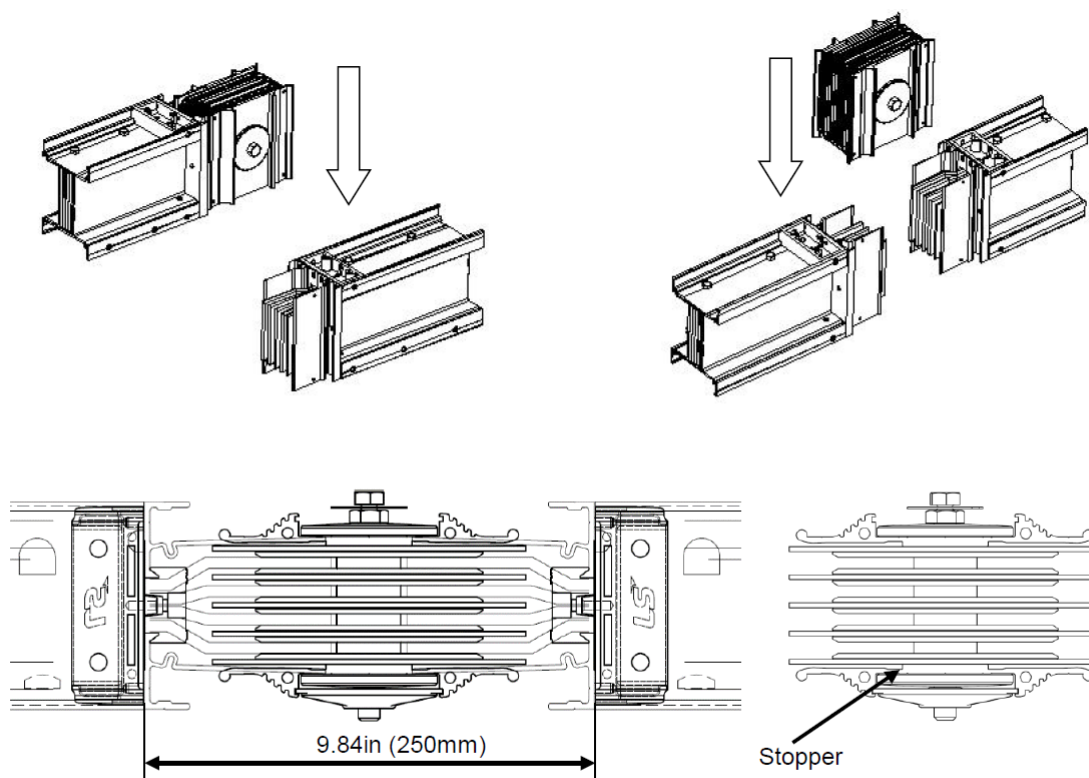

Figure 8. Joint Part

INSTALLATION

3.3.2 INSTALLATION OF JOINT COVER

3.3.2.1 Indoor joint cover

The Series HP joint cover is a basic 2 piece structure. Install in accordance with the following.

1. Check the alignment of the product and make sure that the double headed bolt of the joint kit is broken. (After completion of product installation and busway system check, final joint cover is installed. After assembling the upper joint cover, check the double headed bolt break, then install the joint cover.)
2. The joint cover should be installed after confirming that foreign substances such as dust and moisture in the connection parts is not present. (Generally, if a joint cover is installed after a considerable period of time after installation of the joint kit, the connection part is wrapped with vinyl or the like to prevent foreign matter from entering.)
3. When installing a joint cover, make sure that it is not installed in an area where there is danger of flooding such as pipes, ducts, etc.

4. Make sure that the hole of the joint cover matches the hole of the product and install it. Pre-assembled to allow slight movement during initial assembly.
5. Tighten the bolts in the proper sequence.

* Be careful not to break the bolts when tightened with power tools. (M6 bolt Suitable torque: 80~100 kgf cm (7.85~9.81 N m). Detailed adjustment is possible according to the situation of the construction site.

⚠ WARNING

- After installation is completed, carefully check whether the bolts and nuts of the entire joint cover are tightened or damaged.
- When the bolts for joint cover (M6 X 18mm(0.7 in.)) are damaged, the damaged bolts must be completely removed and reassembled with new bolts.

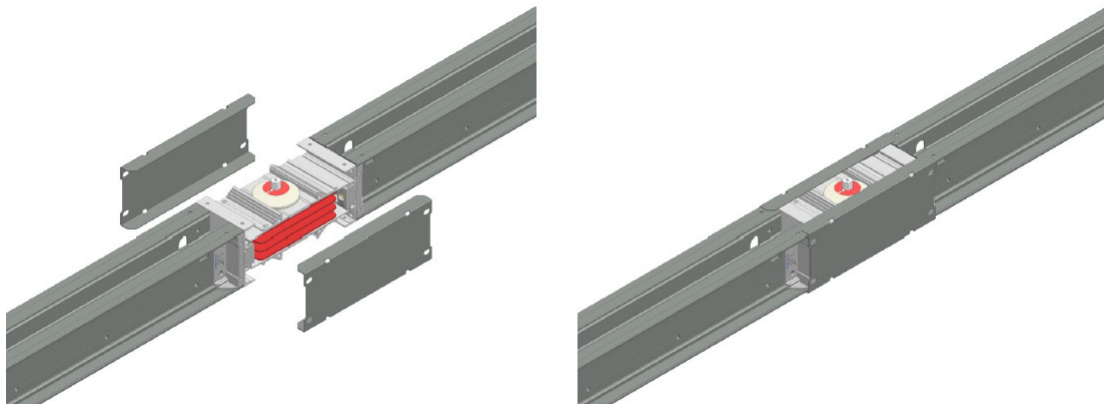

Figure 9. Joint Cover

INSTALLATION

3.4 INSTALLATION OF FITTINGS

3.4.1 Installation of Expansion Joint

The purpose of the expansion joint is to absorb elongation from the busway system, construction as well as mechanical length from building shortening.

Series HP is designed to have flexibility at joint parts. However an expansion joint must be used for below cases.

- When busway is installed through different buildings.
- When a building has expansions.
- When a straight run is abnormally long.
- When busway variant is expected due to big temperature differences at installation area.
- When building shortening is expected with its high rise construction design.

Expansion joint is designed to absorb elongation and transformation on busway route by simultaneous movement of enclosure and conductor. (Max. absorption is 50mm(2 in.)/EA) As enclosure and conductor are designed to move simultaneously, special caution is required for handling & storage on expansion joint.

CAUTION

- When handling and storing, be sure to keep busway in a dry clean room. Keep it in an environment free from condensation, especially because the space inside is empty.
- The enclosure bolts are for structural support of the product. Do not remove it until the installation is complete.
- Expansion joint body part is where sliding occurs. Remove any obstacles that might interfere with the installation, and do not fix the body part with other support brackets.

The precautions for installation are as follows.

1. Expansion bolts should never be removed until installation is complete. Expansion bolts should be removed after the complete installation of the riser part, not removal after expansion installation.
2. Expansion joint for horizontal run busway must be supported by the hanger on the left and right neck area.
3. Expansion joint for vertical run busway must be supported by the medium hanger at upper or lower neck area with precautions to make sure the product is installed straight without bending.

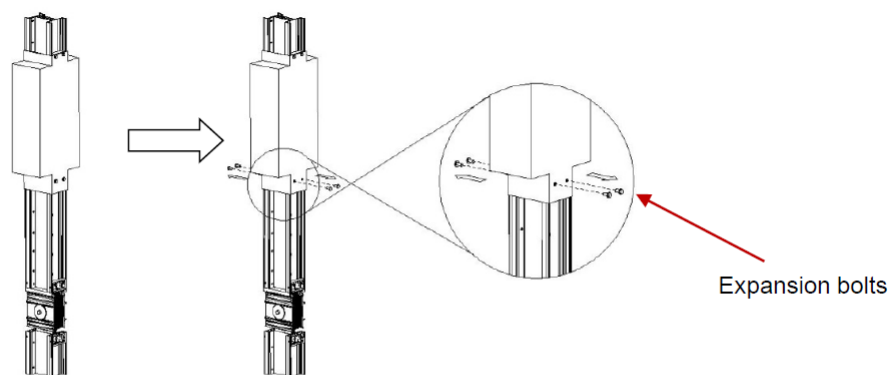

Figure 10. Expansion

INSTALLATION

3.4.2 INSTALLATION OF FLANGED END

Flanged end facilitates mechanical and electrical contact with distribution and boards such as ACB, TR, ATS and MCCB panels. Therefore, the flange or the conductor should not be subjected to excessive impact. The flange plate or the conductor should not be touched or being stressed during handling and moving, and it should be handled firmly using nylon strap as shown below.

Before installation, check the following with the switchboard manufacturer:

- The phase arrangement of the switchboard and the busbar direction must be determined.
- Upon different rating of busway, busbar and its holes at switchboard must be machined to fit with busway flanged end.
- The size of switchgear busbars must be selected safely, considering rated capacity of the power system and busway system.
- Top opening size must be managed per each busway rating, wiring and product type. And the opening should withstand busway weight. (Please refer to the catalogue for the size of flanged end holes and top opening)

⚠ CAUTION

- Flanged end bolt at upper side must be tightened to panel's upper side enclosure. Otherwise, bolt and nut may fall into inside of switchboard when there are vibrations.
- The busbar fastening bolts inside the switchboard are packed separately when shipped. Be sure to use corresponding bolts of the busway capacity.
- After completion of the installation, the grounding tap at the bottom of the flange and the inner earth terminal of the switchboard should be connected to GV cable or ground bus bar. The capacity of the ground wire must be selected corresponding to the ground system and its configuration.

⚠ CAUTION

- When handling and storing, be sure to keep it in a dry clean room.
- Contacting point of the flanged end is surface treated with silver or tin plating for electrical connection. Keep the surface clean and be careful not to apply any mechanical impact.

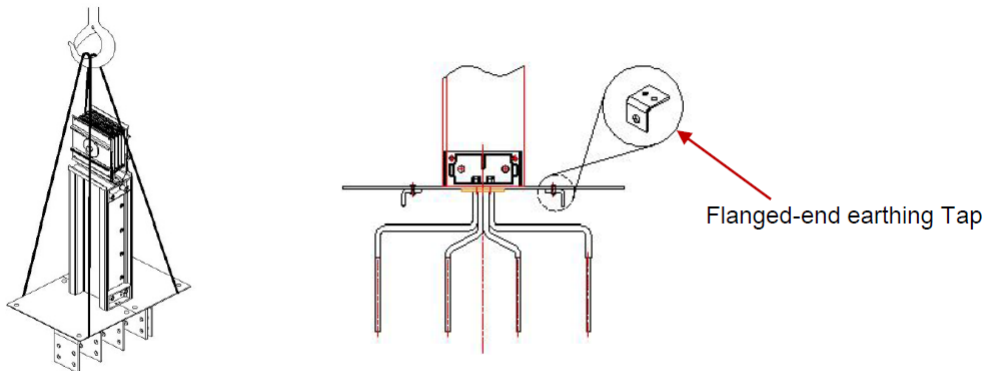

Figure 11. Flange End

INSTALLATION

3.4.3 INSTALLATION OF END CLOSURE

End closure is a product for terminal finishing. Because the conductor charging part is exposed to the outside, it must be installed at the end of the installation line for safety.

- Before installation, make sure that foreign substance is caught or cleaned at the jointing area.
- Make sure that the insulation plate inside the end closure is positioned between the conductors of the product.
- It should not be installed where there is a sudden temperature difference so that condensation does not occur due to the structure with empty space inside. Also, it is a structure that is supported only by the enclosure, so if you step on or apply excessive shock, there is a danger of insulation breakdown.

WARNING

Adding or removing busway lines must work in the power failure state.

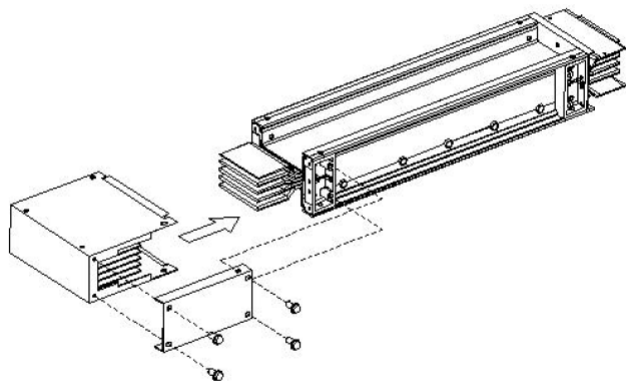

Figure 12. End Closer

3.4.4 INSTALLATION OF REDUCER

The reducer reduces the busway capacity, so the following should be considered when reducer is designed:

- Reducer usage is restricted according to the capacity and branch distance of circuitbreakers installed on busway according to the regulations. An overcurrent circuit breaker must be installed at the time of load branching that does not satisfy the regulations. As shown below, two types of reducer can be installed depending on whether the breaker is installed or not.
- According to NEC Article 364 busway, only 1/3 can be reduced within 15m(49.2 ft) from the end. For example, Min. 300A can be reduced from 900A busway

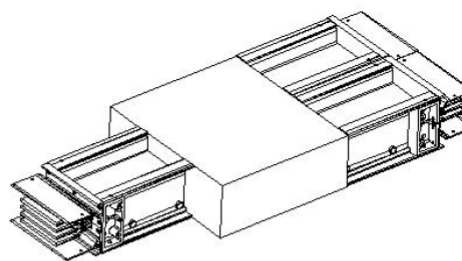

Figure 13. Reducer with kit

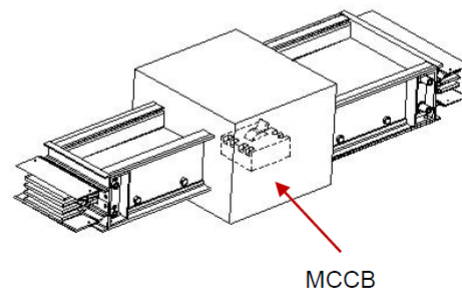

Figure 14. Reducer Box

INSTALLATION

3.4.5 INSTALLATION OF HORIZONTAL TEE

The horizontal tee is for load branching from initial power supply, special precautions are required for its phase sequence.

It is possible to change the phase arrangement in the line branch part. So, it can be used when the phase arrangement of various power devices is not correct. Be sure to check the phase alignment mark and install it after counter checking with approved drawing.

⚠ WARNING

Check the direction of phase array sticker or red circular sticker when installing. Depending on the direction of installation, the phase alignment may change, leading to an accident.

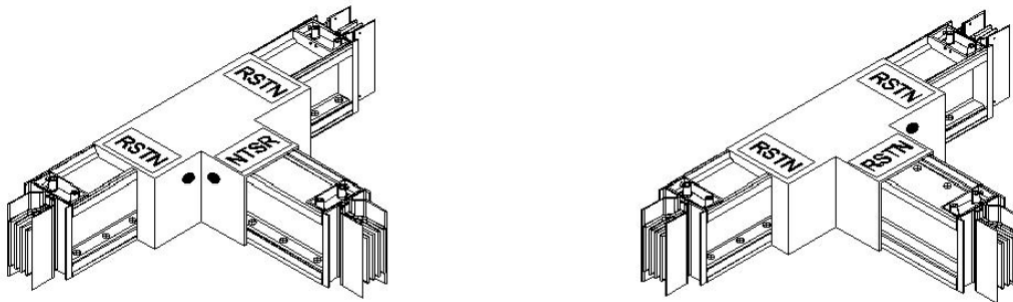

Figure 15. Horizontal Tee

INSTALLATION

3.5 BUS PLUGS

Depending on the type of overcurrent protection device, bus plugs are classified as a substation branch product as follows.

- MCCB Bus Plug
- Fusible Switch Bus Plug (Class R, J and L)

There are Plug-in and Bolt-on type according to the load distribution rating. The Plug-in type is a method of inserting clip type contact into conductor and making electrical contact by tension. Series HP busway distributes the load in Plug-in type up to 800A. The Bolt-on type is used for relatively high capacity load distribution, 800A or more. Since the bolt-on unit and tap busbar connected to the product are directly fastened by bolts, it must be carried out after power off.

The plug-in unit can be installed in operation state if allowed depending on the country and site regulations. During work on the operation state, inner circuit breaker must be OFF. It is necessary to equip installers with safety gear such as safety helmets, insulation gloves and safety glasses. Also check the safety

precautions such as earthing protection equipment before working on operating line. Bolt-on unit is shipped with tap protection box attached to each tap. To protect the tap busbar, keep it until the installation and remove the protection box before bolt-on unit installation.

The plug-in unit has the contact inserted into the conductor, making electrical contact and being entirely silver plated. Be sure to protect it from contaminants and moisture when storing and handling. In particular, keep the standard interval of the contact for proper tension as provided. If you insert a driver or other tool and spread it, it will lead to an accident such as an open phase or contact failure.

Bus plug should not be installed at the joint point. The joint part must be accessible for the future inspection, expansion, and replacement. When designing the busway system, check the dimension depending on the capacity of the load so that the unit is not placed in the joint part.

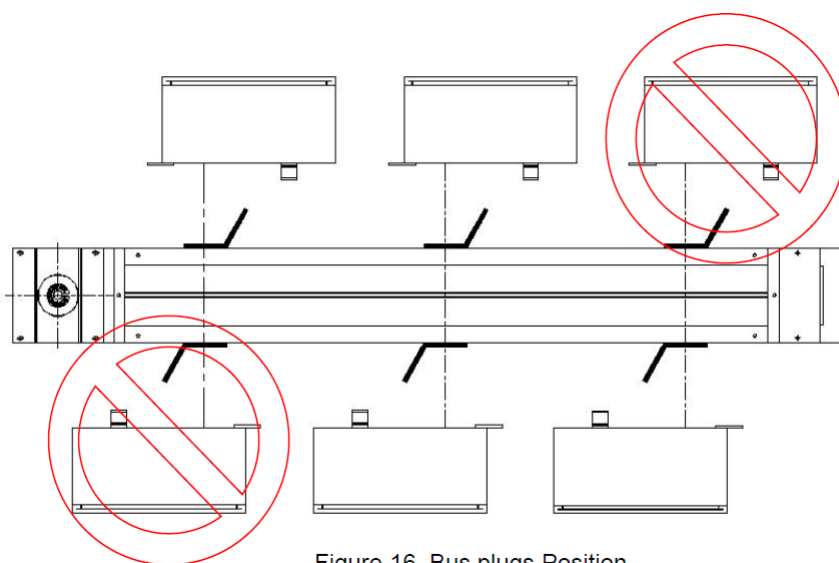

Figure 16. Bus plugs Position

INSTALLATION

3.4.5 INSTALLATION OF HORIZONTAL TEE

Equalizer type joint kit must be used at plug-in feeder of two or three stacks (from 2500A to 6000A).

Before designing the busway routing, sufficient space must be ensured in order to install the bus plug.

The inter-lock structure is applied to Series HP bus plug, and ON/OFF operation is possible with the unit external lever without opening the door. The MCCB operating status can be checked externally. When MCCB is ON, 1) The door does not open and 2) the busway box is not separated. The box external lever is set to OFF before installation. It is fixed with the lever fixing bolt and does not move to prevent lever/box damage during transportation. Before installation, be sure to check whether it works after removing the lever fixing bolt. Make sure that the ON/TRIP/OFF indicator is displayed correctly.

Bus plugs must be installed firmly on the product. If there is a gap in the installation, there is a risk of accidents due to poor contact and could be susceptible to vibration and noise. The installation should be carried out according to the manual. If bus

plugs are larger or heavier than standard plug-in / tap off box, bus plugs are necessary to support the system with additional hangers or supports.

▲ WARNING

- When handling and storing, be sure to keep it in a dry clean room.
- Keep the finger contact clean and be careful not to apply mechanical shock.
- When working on operation state, you must follow the safety procedures.
- Be sure to check approved drawings and keep appropriate number of spare plug in hole / tap to prepare for design change, expansion and replacement.
- Modification or disassembly of the product in the field is strictly prohibited. If changes are made due to site conditions, they must be corrected after returning to the factory.
- Following figures are examples. There may be differences by ampere frame.
- The inter-lock structure can be applied or not.

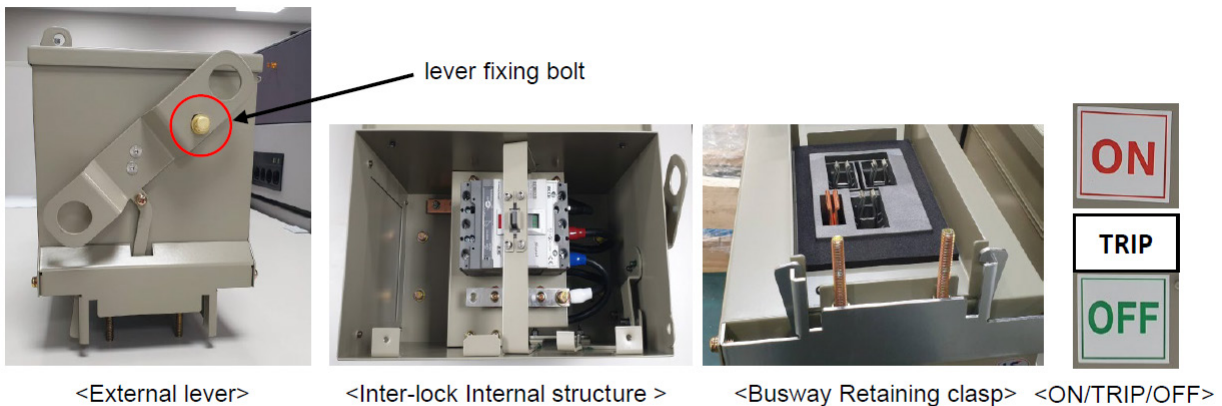

Figure 17. Circuit Breaker Bus Plugs Description

INSTALLATION

3.5.1 PLUG-IN UNIT

Plug-in unit & feeder description

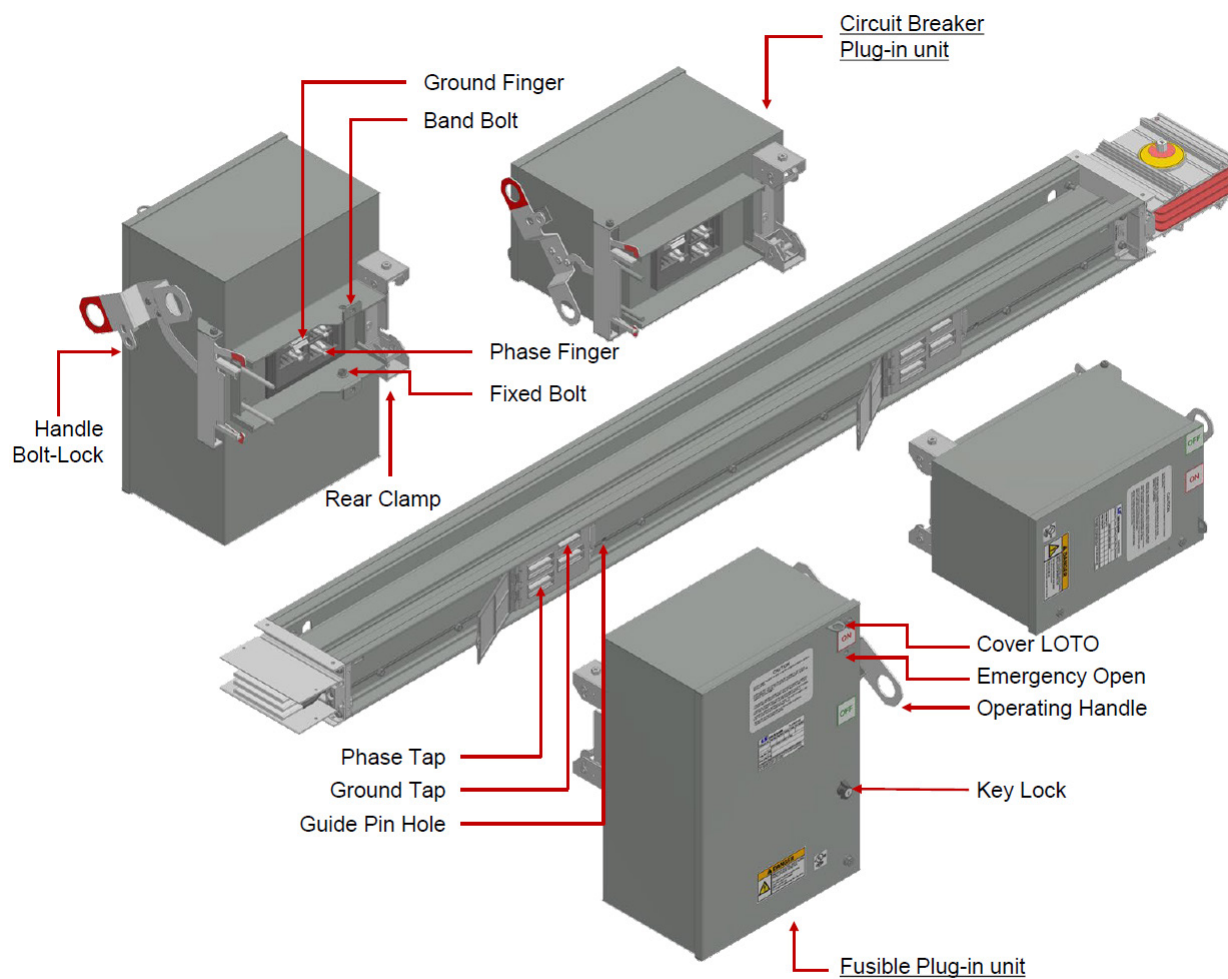

Figure 18. Plug-in unit and Feeder Description

INSTALLATION

PRE-INSTALLATION PLUG-IN FEEDER

- Check the breaker rating and installation point with approved drawings.
 - Check the specification of the busway, the specification of the plug-in unit and the wiring.
 - Check the phase arrangement between the busway and the breaker.
 - Please note that the phase arrangement of breakers could be different depending on the type and country of the breaker manufacturer.
1. 3.5.1.1 Ensure that the busway is firmly fixed in place.
 2. Verify that there is no current flowing through the busway's enclosure.
 3. Unbolt the busway's PH cover and open it. (Figure 19, a, b)
 4. Check that the tap bar is properly aligned.
 5. Inspect the plug-in mold for any foreign material or moisture penetration. (Figure 19)

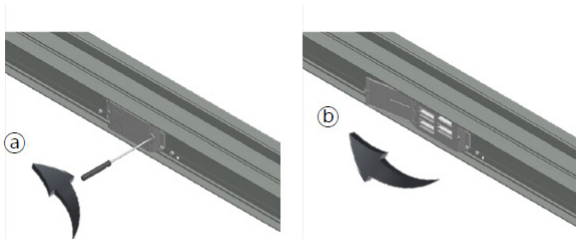

Figure 19. Busway Pre-installation

⚠ DANGER

- This plug-in unit should only be installed and serviced by qualified personnel.
- Turn off the power of busway prior to installing the plug-in unit.
- Verify that there is no current flowing through the busway's enclosure. (Check for short circuit)
- Ensure that the busway is firmly fixed in place.

PRE-INSTALLATION PLUG-IN UNIT

1. Inspect the appearance of the product.
2. Place the operating handle on OFF (O) position. (Figure 20, 21)
3. Make sure that the bolt-lock of the handle is locked. (Figure 20, 21 a)
4. Remove two nuts on the guide pins. (Figure 20, 21 b)
5. Remove two fixed bolts. (Figure 20, c)
6. Loosen the upper and lower bolts of the rear clamp. (Figure 22)

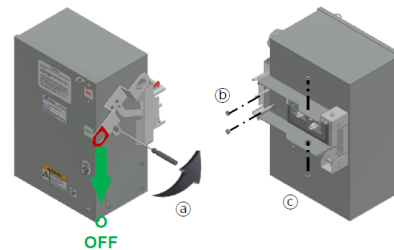

Figure 20. Fusible Plug-in unit Pre-installation

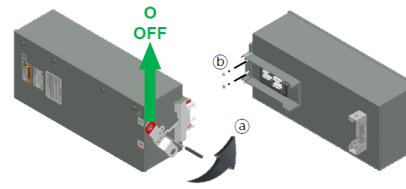

Figure 21. MCCB Plug-in unit Pre-installation

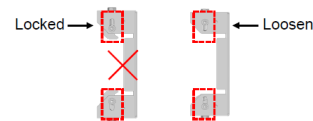

Figure 22. Rear Clamp

⚠ WARNING

- This plug-in unit should only be installed and serviced by qualified personnel.
- When handling and storing, ensure the unit is kept in a dry, clean room.
- Keep the finger contacts clean and avoid applying any mechanical shock.
- Turn off the plug-in unit before installation to prevent electrical shock.

INSTALLATION

MOUNTING THE PLUG-IN UNIT

1. Ensure proper alignment between the tapbar body and the finger safety of the plug-in mold.
2. Tilt the plug-in unit toward the guide-pins and insert the guide-pins into the guide-pin holes of the busway to adjust the position. (Figure 23, a)
3. Use the guide-pins as support points and press the left side of the plug-in unit to insert the finger contact into the tap bar. (Figure 23, b)
4. Tighten the upper and lower nuts of the guide-pins. (Figure 24, c)
5. Tighten the upper and lower fixing bolts. (Figure 25, d)
6. Tighten the bolts of the rear clamp. (Figure 26, e)
7. For large capacity plug-in units of 400 A and above, use fixing bands to firmly secure the box and busway. (Figure 27, f)
8. Inspect the installation to ensure proper installation.

NOTICE

- Check the status of bolts and nuts to ensure proper installation.

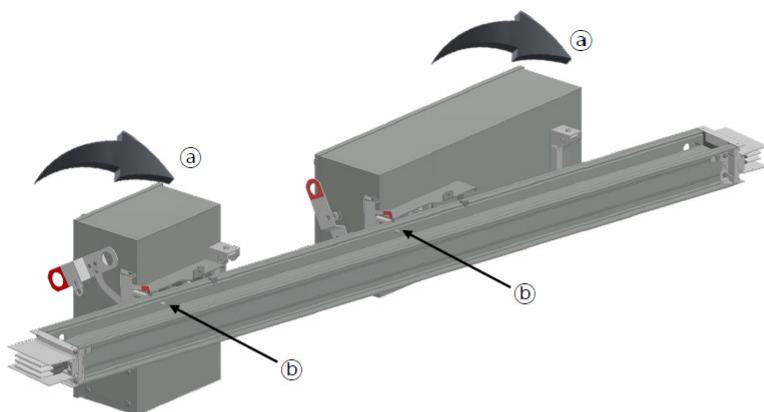

Figure 23. Mounting

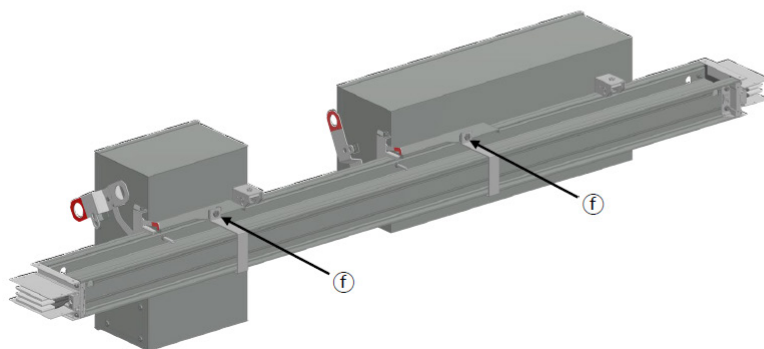

Figure 27. Fixing Band

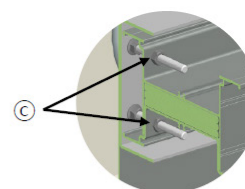

Figure 24. Guide Pins

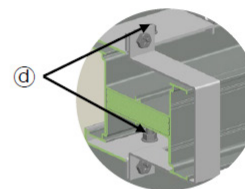

Figure 25. Fixing Bolts

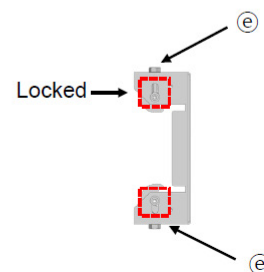

Figure 26. Rear Clamp

INSTALLATION

Drop rod or latch installation

1. For large capacity plug-in units of 400 A and above, use a drop rod or latch to firmly secure the box. (Figure 28, a)
2. Slot hole size is $\varnothing 0.6 \times 1.0$ inch.

Operation Instructions

1. Release the handle bolt-lock of plug-in unit.
2. Turn on the plug-in unit.

Operating Position Instructions

Fusible plug-in unit

- Turn-on position. (Figure 29)
- Turn-off position. (Figure 30)

Circuit Breaker Plug-in unit

- Turn-on position. (Figure 31)
- Turn-off position. (Figure 32)

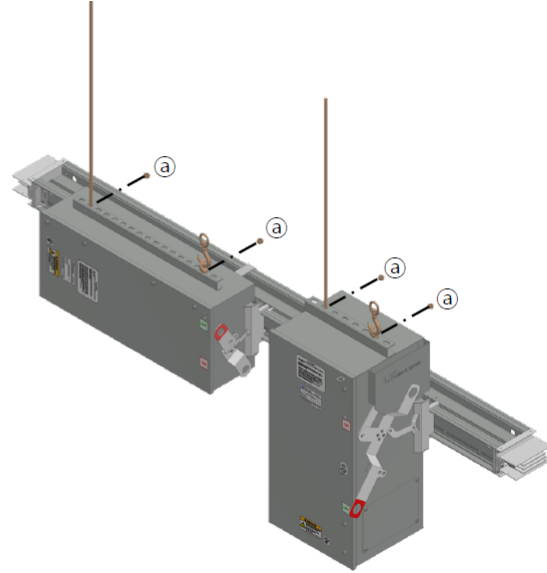

Figure 28. Drop Rod or Latch Installation



Figure 29. Turin-on

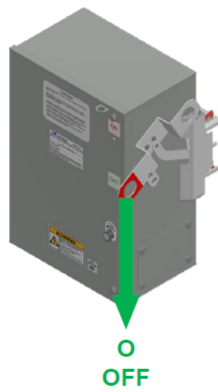

Figure 30. Turin-off

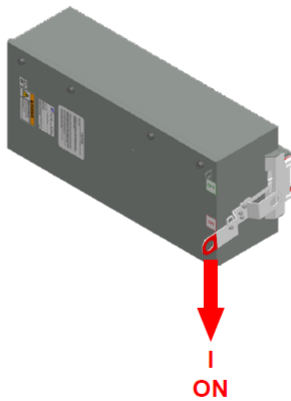

Figure 31. Turin-on

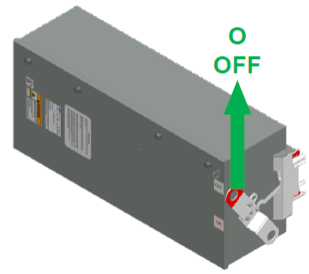

Figure 32. Turin-off

INSTALLATION

3.5.2 BOLT-ON UNIT

Bolt-on unit & feeder description

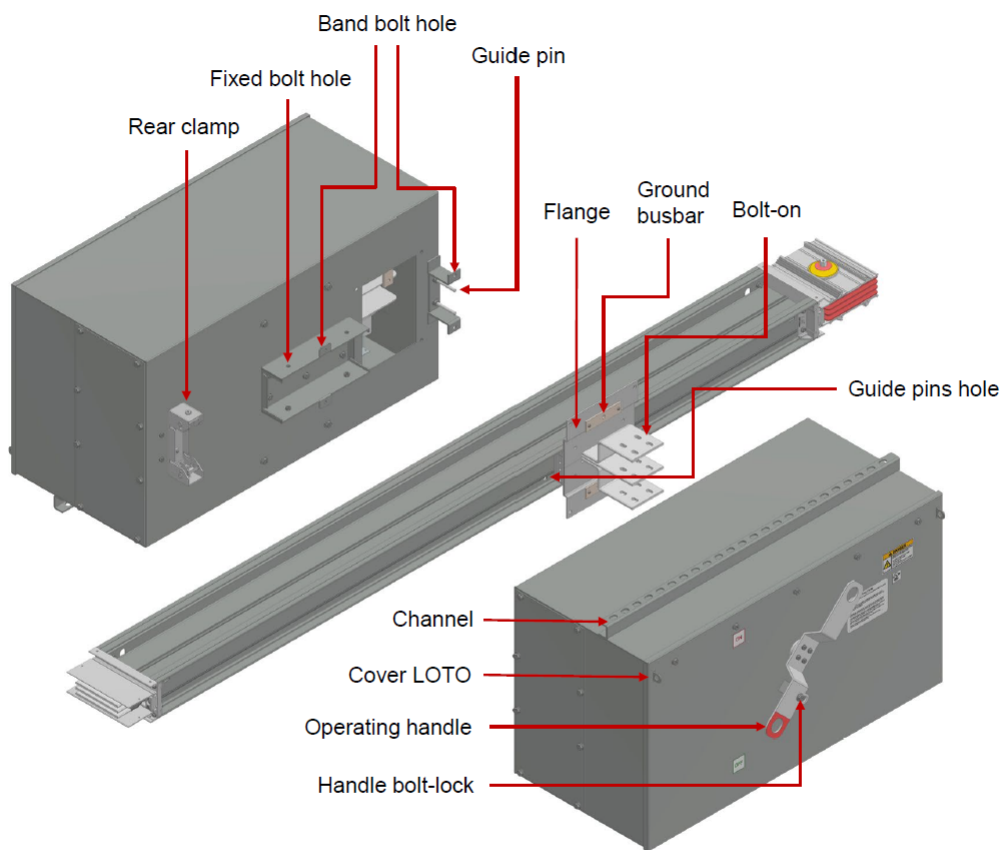

Figure 33. Bolt-on unit and Feeder Description

INSTALLATION

PRE-INSTALLATION BOLT-ON FEEDER

- Check the fused switch and fuse rating and installation point with approved drawings.
 - Check the specification of the busway, the specification of the bolt-on unit and the wiring.
 - Check the phase arrangement between the busway and the fused switch.
 - Please note that the phase arrangement of breakers could be different depending on the type and country of the fused switch manufacturer.
 - It must be installed in power failure state.
1. Ensure that the busway is firmly fixed in place.
 2. Verify that there is no current flowing through the busway's enclosure.
 3. The bolt-on protection box is attached to the product to protect the conductor. The factory shipment should be maintained until installation. Check that the Bolt-on is properly aligned.
 4. Loosen the bolts of the bolt-on protection box and remove the bolt-on protection box at the top and check for internal cleanliness and do not remove the flange at the bottom. (Figure 34, a, b)

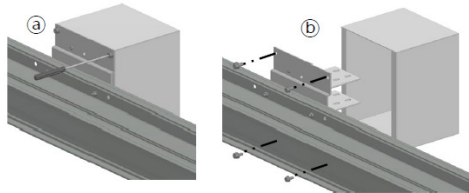

Figure 34. Busway Pre-installation

⚠ DANGER

- This Bolt-on unit should only be installed and serviced by qualified personnel.
- Turn off the power of busway prior to installing the Bolt-on unit.
- Verify that there is no current flowing through the busway's enclosure. (Check for short circuit).
- Ensure that the busway is firmly fixed in place.

PRE-INSTALLATION BOLT-ON UNIT.

1. Inspect the appearance of the product.
2. Make sure that the operating handle on OFF (O) position. (Figure 35)
3. Make sure that the handle bolt-lock is locked. (Figure 35, a)
4. Remove two pair of the guide pins nuts. (Figure 35, b)
5. Remove four pair of the fixed bolts. (Figure 35, c)
6. Loosen two pair of the rear clamp bolts. (Figure 36)

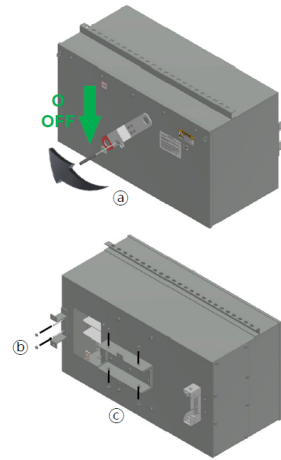

Figure 35. Bolt-on unit Pre-installation

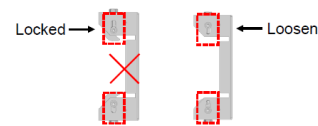

Figure 36. Rear Clamp

⚠ WARNING

- This bolt-on unit should only be installed and serviced by qualified personnel.
- When handling and storing, ensure the unit is kept in a dry, clean room.
- Keep the bolt-on clean and avoid applying any mechanical shock.
- Turn off the bolt-on unit before installation to prevent electrical shock.

INSTALLATION

MOUNTING THE PLUG-IN UNIT

1. Insert the guide pins into the guide pin holes of the busway to align the position. (Figure 37, a)
2. Use the guide pins as support points and press the rear side of the bolt-on unit. (Figure 37, b)
3. Assemble the flange of the bolt-on protection box and the enclosure of the bolt-on unit with four pair of the bolts. (Figure 37, c)
4. Lock two pair of the guide pins nuts. (Figure 38, d)
5. Lock four pair of the fixing bolts. (Figure 39, e)
6. Lock two pair of the rear clamp bolts. (Figure 40, f)
7. Use the fixing bands to firmly secure the bolt-on unit and busway. (Figure 41, g)
8. Inspect the installation to ensure proper installation.

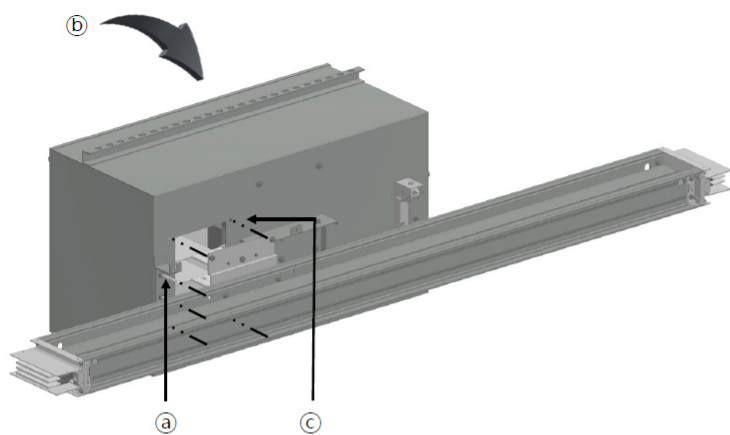

Figure 37. Mounting

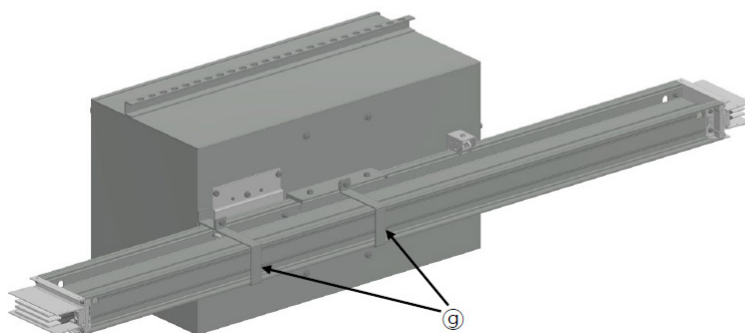

Figure 41. Fixing band

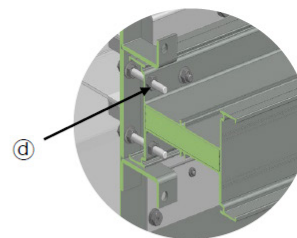

Figure 38. Guide pins nuts

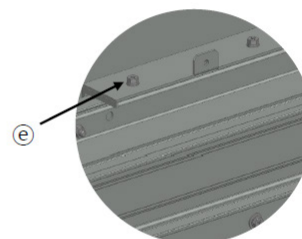

Figure 39. Fixing bolts

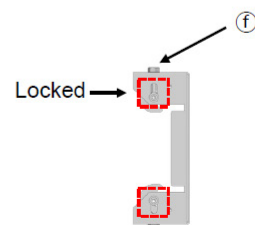

Figure 40. Rear clamp

INSTALLATION

MOUNTING THE BOLT-ON UNIT

Connect the ground busbar on the left or right side of the flange to the ground wire inside the bolt-on unit. (Figure 42)

Connect the bolt-on of the bolt-on unit and primary side of the fused switch with the flexible busbar. At the time of shipment, the primary side of the fused switch and the flexible busbar are assembled firmly.

(Figure 42)

During installation firmly assemble the flexible busbar connected to the bolt-on.

NOTICE

Check the status of bolts and nuts to ensure proper installation.

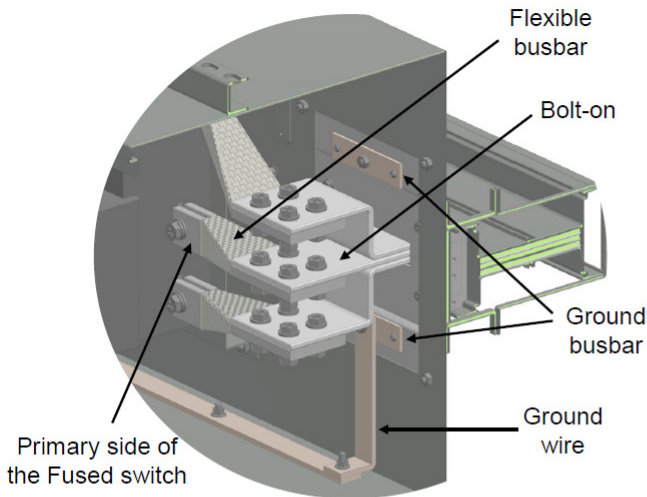

Figure 42. Drop Rod or Latch Installation

Drop rod or latch installation

1. Use a drop rod or latch to firmly secure the bolt-on unit. (Figure 43, a)
2. Slot hole size is $\varnothing 0.6 \times 1.0$ inch.

Operation instructions

1. Loosen the handle bolt-lock of bolt-on unit.
2. Turn on the bolt-on unit.

Operating position instructions

- Turn-on position. (Figure 44)
- Turn-off position. (Figure 45)

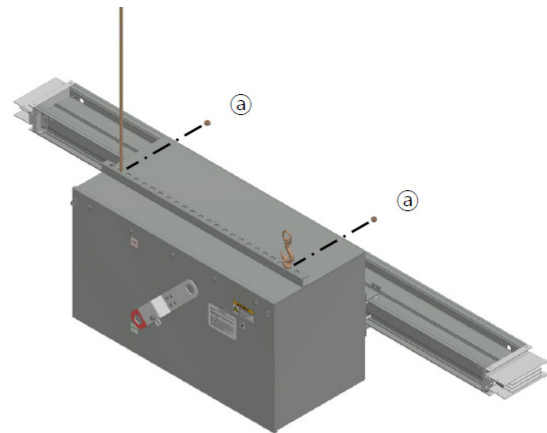

Figure 43. Drop Rod or Latch Installation

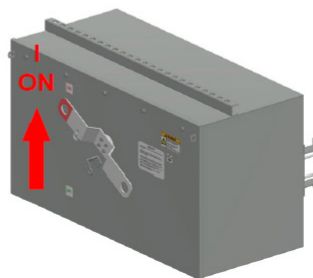

Figure 44. Turn-on

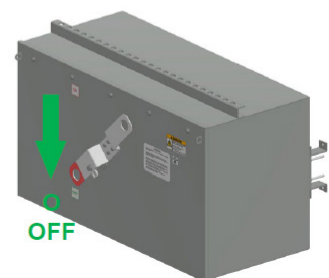

Figure 45. Turn-off

INSTALLATION

3.6 OTHERS

3.6.1 Wall flange

When busway penetrates through the wall, both sides must be finished with steel plate of 1.6mm(63 mil) or more. When setting fire prevention and explosion-proof division by building or area, glass fiber or fire form can be added inside wall. When installing busway, check the specifications and check the wall finish specifications. If there is no addition, steel flange finishing is set as standard for wall and floor penetration

3.6.2 Direction of Installation

Starline Series HP can be mounted horizontally (flatwise direction) or vertically (edgewise direction). However, when horizontally installed, it should not be turned upside down. Because the drain hole is not machined on the bottom side of the product structure, when installed upside down, fluid such as water may float on the product and there is a high risk of ingress through the M8 bolt for assembly. Be sure to check the direction of installation.

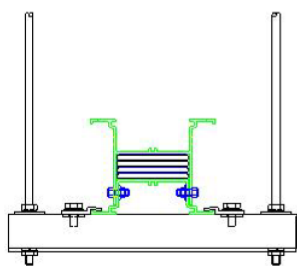
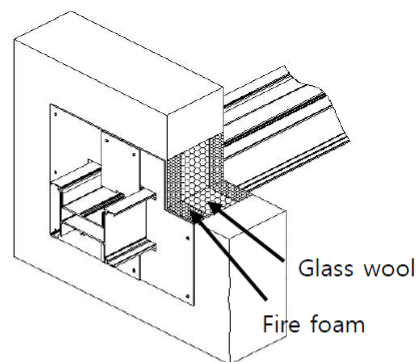
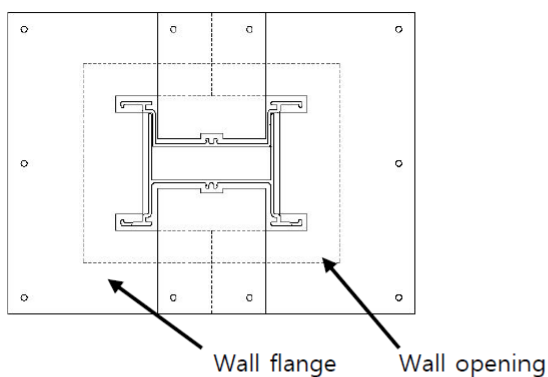

Flatwise direction

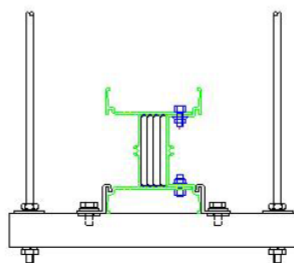

Edgewise direction

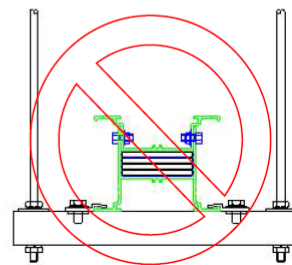

INSTALLATION

3.6.3 BUSWAY MEASUREMENT

In general an empty section is left in the middle of the line. This is to prepare for variations in the dimensions of approved drawing, errors in settling of the switchboard, and other interference or unexpected line changes. After completing the installation all sections except this empty part, measure and manufacture the actual part and construct the final line.

In the measurement of the actual part,

1. Measure the distance between the ends of the enclosure as shown below.
2. The actual dimension is the measured distance minus the connection part of 250mm(9.84 in.).

NOTICE

It is necessary to clearly distinguish the distance between the enclosures ($L + 250\text{mm}(9.84 \text{ in.})$) or actual product size (L). There is a high risk of failure due to errors in exchanging information when manufacturing the actual section.

START-UP TEST

After the installation is completed, please follow the procedure of test below to guarantee the quality.

4.1 CHECK POINT BEFORE ENERGIZING

1. Make sure that all connecting bolts in joint part and flanged end connections are properly tightened.
2. Check that vertical and horizontal support brackets and hangers are properly fastened, the horizontal bolt (stud bolt) was not loosened and whether the vertical part is bent or the spring hanger is not excessively deformed.
3. Check if all circuit breakers (MCCB or fuse in plug in / tap off box) in the branch are OFF. (It is necessary to check if the MCCB indicator outside the box is facing OFF).
4. Check that sufficient insulation is ensured with the switchboard connected to the busway system and that it is mechanically securely fastened.
5. Insulation resistance measurement is carried out to confirm short-circuit or phase-to ground fault or ground fault. Insulation resistance value of busway varies according to the length of the system line, the capacity of busway, and the ambient humidity during measurement. Therefore, the line name, capacity, humidity and temperature should be recorded together when making the insulation resistance test report. Insulation resistance standards vary from country to country, but $1\text{M}\Omega/100\text{m}$ ($0.3\text{M}\Omega/100\text{ft}$) is common ($0.5\text{M}\Omega/100\text{m}$ ($0.15\text{M}\Omega/100\text{ft}$) for Germany). If insulation resistance below this value is measured, you must get technical support including product and installation checks.
6. Check phase alignment with connected breakers and power devices.

4.2 PRECAUTION DURING ENERGIZING

1. When the busway is first energized, check for short-circuit and ground fault due to poor installation. Energizing must be carried out in the presence of a busway technician who can always take on-site action.
2. Due to the busway system feature, it is installed through several layers and walls, so it must be energized after powering off the circuit breaker for branching.
3. When the load is applied, the load must be turned on sequentially. Turn ON the load on the power supply side and turn ON the load on the terminal load side sequentially. That is, starting from the main side, the load is sequentially applied to the end load at the feeder side
4. After energizing, turn 'ON' the overcurrent breaker, and then operate the switches of the individual lighting, heat and power loads.
5. During normal operation, some vibration and noise may occur throughout the busway system, but excessive noise and vibration may be caused by damage to parts inside the product, misplacement of metal parts, improper bolt tightening. Check them during energizing process.
6. Since the electric spark during the test run is a problem in the busway enclosure, insulator or system, it is necessary to immediately identify the cause after line switchover and eliminate the cause of spark occurrence element.

⚠ WARNING

- Operation in the energized state can result in serious injury or death. Therefore, it is necessary to pay attention to safety precautions and work with care.

MAINTENANCE

After the first energization with Series HP, generally it is not necessary to test with turning off the power if the following cases are met (maintenance-free).

1. Installation is carried out properly according to the manual.
2. Line is energized by the start-up test procedure, and insulation test or related inspection is assured.
3. Mechanical damage of the product does not occur due to excessive external impact during operation. It is not continuously interfered by dust or other equipment.
4. It is not continuously exposed to water or other liquids, and there is no condensation inside or outside the product due to rapid temperature difference.
5. It is not affected by impacts such as short circuit, fire and gas.
6. There is no use of abnormal load.

If any of the above items need inspection, detailed inspection is required by Starline. However, this is only applied to the busway. Other circuit breakers, cables, and bus bars should be inspected according to the each manufacturer's checklist.

5.1 GENERAL MAINTENANCE WORK

- If an accident occurs due to a short circuit, ground fault, or physical impact of the product, continuous inspection is necessary after the accident is recovered.
- In general, the most effective method of inspection when the busway is energized is to use the infrared camera to monitor the temperature of joint part and enclosure of busway. Since the weakening of the insulation and the weakening of fastening force on the enclosure and the joint part lead to the temperature rise, please measure the

infrared temperature regularly and compare the result to the normal condition.

- When repairing, upgrading or replacing busway, it is necessary to remove dust. Use a brush or vacuum cleaner to remove dust. Do not use equipment such as an air compressor or blower as this may cause dust to enter into inside of the busway or joint part.
- When re-energizing after turning off the power for inspection, expansion, and replacement, re-energizing should be carried out according to the test item of the previous chapter.

▲ WARNING

- Work under the line when powered can result in serious injury or death. Therefore, you should pay close attention and follow safety regulations.
- Maintenance work must be done with all power devices turned off except infrared camera measurement.

5.2 EXPANSION OF BRANCH (REMOVAL AND INSTALLATION OF BUS PLUGS)

One of the biggest advantages of the busway system is that it is easy to remove and install the bus plugs. If you need to add plug-in / bolt-on unit due to load expansion, you should check if there is spare plug-in hole or tap-off hole on the busway first. If there is, insert the bus plugs in the required position. Please take note that plug-in unit (~630A) can be removed while the line is powered, however regarding bolt-on unit (800A~) power should be turned off as it has bolt assembled structure.

If there is no available spare hole, you must add a new line with plug-in hole or tap-off hole.

MAINTENANCE

5.3 EXPANSION AND REPLACEMENT OF BUSWAY LINE

Due to the fluctuation of the load, it needs to expand or replace the line of the busway. It must be carried out when the power is turned off and keep the following 5 safety regulations.

1. Separate the line.
2. Install the safe guard line. (Prevention of arbitrary energization of other workers).
3. Confirm the power is turned off. (Using meter stick or tester).
4. Check the ground connection and short-circuit between each phase.
5. Install the safety cover and guard in order to keep away from other power devices.
 - The handling and storage of the product during the expansion and replacement should be in compliance with the handling and storage items of the previous chapter.
 - It is necessary to expand and replace by technicians or experts who have experience in busway construction.
 - Must be installed while wearing appropriate safety gear, such as helmets, safety shoes, safety belts, safety glasses, insulated gloves, etc.)

⚠ WARNING

- Work while the line is powered can result in serious injury or death.
- Therefore, you should pay close attention and follow safety regulations.

5.3.1 Expansion and replacement of horizontal busway line

1. Disconnect all branch loads connected to the busway line. (Plug in unit breaker 'OFF')
2. Disconnect the main power source.

3. busway is completely disconnected from the other power sources. Safety guard should be installed before the line is re-energized.
4. Product separation
 - In case of initial separation, it must be separated from the side in the transverse direction. After you separate initial part, you can separate the part in the both transverse and longitudinal direction. Please note that it is easier to separate the feeder first for the initial separation compare to separating the elbow first.

5.3.2 Expansion and replacement of vertical busway line

1. Before separation, check if it is in compliance with the 5.3.1~3 on the previous chapter.
2. When separating the vertical part, it is necessary to consider the product length change due to thermal expansion. So we recommend to do the work after the line is cooled down. (approximately 12 hours after the line is shut down)
3. Tighten the red bolts of spring hanger of each floor up to the top of the hanger bracket so that it can be firmly supported at each floor when removing the product.
4. When you remove the product, please follow the instruction 5.3.1 -4
5. When removing intermediate products from each floor, it is necessary to work with caution because the supporting structure changes and the deformation and excessive weight of the product may concentrate on the connection part and change the connection part. (Especially when the floor height is high and 2Pcs or more is installed in the floor).
6. Remove spring or rigid hanger from base-channel.
7. Please do not lean the products against the wall during expansion or installation.

MAINTENANCE

5.3.3 Separation, storing and reinstalling of the joint kit

1. The disconnection procedure of the connection part is carried out in the reverse order of the installation procedure.
2. During disconnection procedure, make sure that the M6 X 18L Hexa bolt for fastening the joint cover does not enter inside of the busway and do not damage the gasket on the joint cover.
3. Loosen the high tension bolt (M12 high tension bolt) for joint kit and remove the connection part. Be careful not to damage the head of the bolt with the proper tool.
4. Please note that there is a risk of slipping when disconnecting the high tension bolt because the busway joint part and joint kit are fixed to each other by the inter-plane friction force.
5. The separated joint kit must be stored in a dry and clean place to prevent dust from being inserted. If the surface of the conductor in the joint kit is dirty or corroded, it may lead to unexpected heat generation or accidents at the joint part.
6. Care must be taken when reusing a joint kit. Since the head of the double head bolt is already broken at the time of initial construction, it must be tightened with torque wrench 800~1000 kgf·cm (78.45~98.07 N · m) when replacing or reinstalling the Double-Head bolt.

CAUTION

- When removing the joint kit, there is a risk that the kit slips down to the bottom after the bolt's fastening force is lost. The connection kit must be firmly supported during disconnection procedure.

TEST REPORT – N PHASE O

Test Report

Tester	Check	Confirm

PJT	
Date	

TEST DATA						
TEST ITEM	Line Name	Specification	Before	After	Before	After
Insulation Resistance (MΩ)	Dielectric					
	R-S					
	R-T					
	R-N					
	S-T					
	S-N					
	T-N					
	R-G					
	S-G					
	T-G					
Dielectric (μA)	N-G					
	RT-SNG					
Phase Sequence/ Conductor & Earth Continuity	SN-RTG					
	R-G					
	S-G					
	T-G					
N-G						

※ Insulation Resistance (DC 1kV) : : Line length 0~15m → 100MΩ ↑, 15~60m → 50MΩ ↑, 60m ↑ → 20MΩ ↑
 ※ Dielectric Test (DC 3kV for 1 minutes) : leakage current 5mA ↓

TEST REPORT – N PHASE X

Test Report

PJT	
Date	

Tester	Check	Confirm

TEST DATA										
TEST ITEM	Line Name	Specification	Before		After		Before		After	
Insulation Resistance (MΩ)	Dielectric									
	R-S									
	R-T									
	S-T									
	R-G									
	S-G									
Dielectric (μA)	T-G									
	RT-SG									
	S-RTG									
Phase Sequence/ Conductor & Earth Continuity	R-G									
	S-G									
	T-G									

※ Insulation Resistance (DC 1kV) : Line length 0~15m → 100MΩ ↑, 15~60m → 50MΩ ↑, 60m ↑ → 20MΩ ↑
 ※ Dielectric Test (DC 3kV for 1 minutes) : leakage current 5mA ↓

INSTALLATION OF HANGER

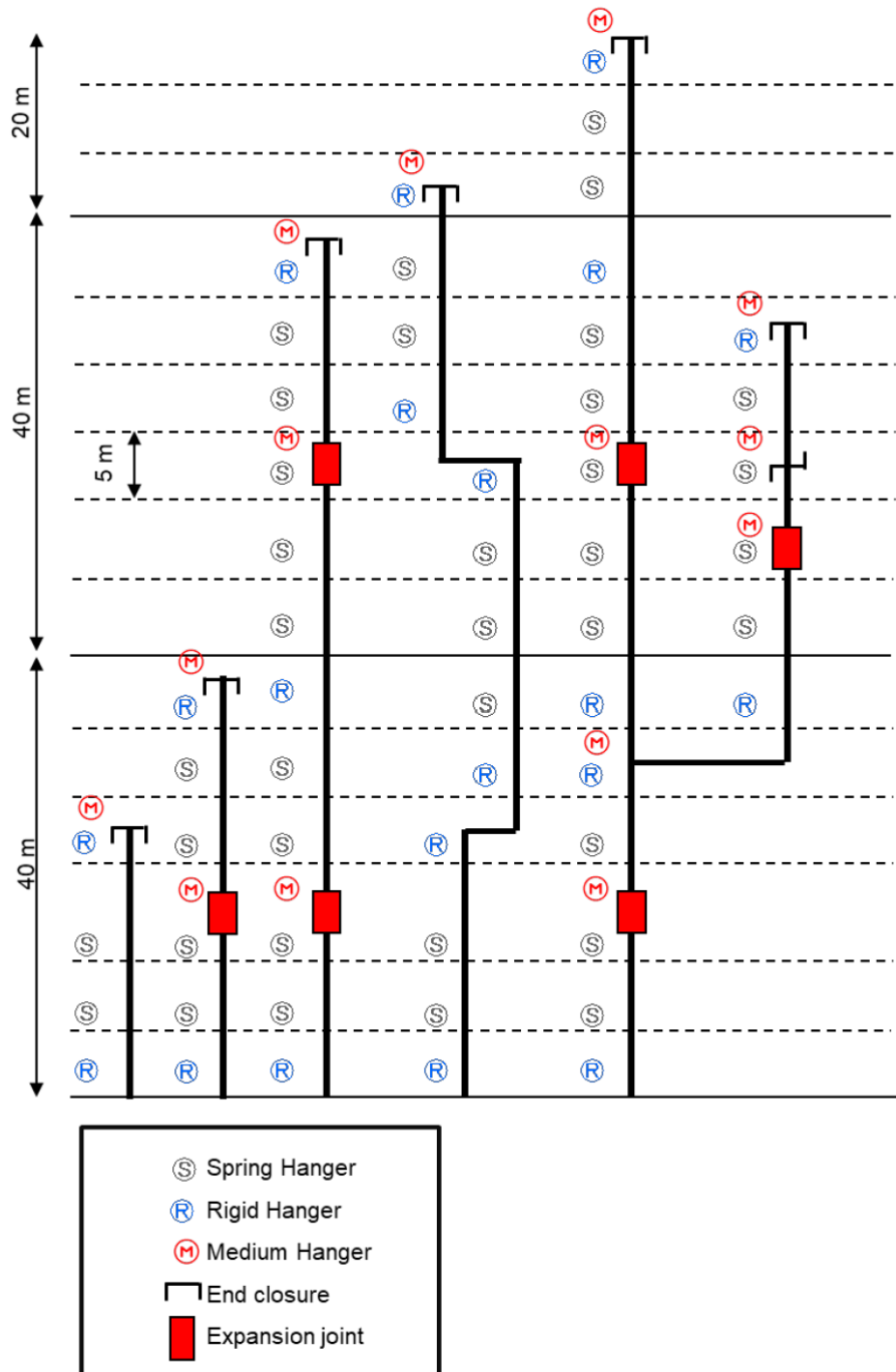

Starline[®]
A brand of  Legrand

Starline Holdings, LLC
724.597.7800
starlinepower.com