

Reliability, Flexibility, and Safety

The Three Essential Qualities You Should Look for
in a Track Busway Power Distribution System



ABSTRACT

Track busway systems are quickly becoming the solution of choice in data centers, industrial and manufacturing plants, and other facilities with high-level power distribution needs. However, not all busway systems are the same. An effective busway system offers three essential qualities – (1) Reliability (2) Flexibility and (3) Safety. When evaluating a busway system, you should apply these qualities to four primary elements: (1) track busway sections (2) joints between sections (3) plug-in units (or tap-off boxes) and (4) power monitoring systems. Furthermore, you should look for a busway solutions provider with the experience, quality, and service offerings to serve as a reliable business partner for your company. By applying the principles outlined in this white paper, you will be able to select a top-quality busway solution that will serve the ongoing power needs of your facility over the long run.

INTRODUCTION

For data center owners and Consulting and Specification Engineers (CSEs), busway systems

are rapidly becoming the solution of choice for effective power distribution. Busways can be suspended from the ceiling, placed on vertical supports, or even mounted on the server cabinets themselves to provide a direct power source to servers and racks.

Busway systems offer numerous advantages over traditional Remote Power Panels (RPPs). Suspended or mounted track busways eliminate the need for an RPP, allowing you to make better use of data center space. Busways also eliminate the need to run power cables and whips under plenums in a raised floor, allowing cooling air from below to flow unobstructed to the servers. If in-row cooling units are used along with busways, it eliminates the need for the raised floor itself.

A busway system gives you full visibility over your power distribution system, making it easier to do maintenance and troubleshooting. Unlike RPPs, electricians don't have to shut down the entire system, or do hazardous work on a live and

exposed panel, in order to change out a single circuit breaker. Using plug-in units (a.k.a. tap-off boxes), which are inserted into the busway's open channel and connected to the internal busbars, you can easily and safely swap out old circuits and replace them with new ones in a matter of minutes.

But not all busway solutions are the same; some busway systems work better, last longer, and require less maintenance than others. In evaluating a busway solution, you should look for three important qualities:

- **Reliability** - An effective busway system provides reliable and efficient power distribution, a maintenance-free joint design, and a long useful life, to ensure continuous uptime for your IT infrastructure.
- **Flexibility** - An effective busway system gives you flexible design and power distribution options, allowing you to build out, scale up, and adapt your IT loads according to your changing power and facility needs.
- **Safety** - The elements of a busway system should guarantee safety for your workers, your IT infrastructure, and your facility.

In this white paper, we will examine these three qualities in detail, and apply them to the individual elements of a track busway system.

NOTE: Although this white paper focuses on data center facilities, many other types of facilities such as assembly plants, manufacturing and distribution centers, laboratories, retail stores, etc., can also benefit from using a busway system for power distribution. This report will tell you what qualities you should look for in a busway solution, no matter what your industry.

THE IMPORTANCE OF THE THREE QUALITIES

Before we look at how to evaluate the elements of a busway solution, let's take a look at why these three qualities are essential in a power distribution system.

IMPORTANCE OF RELIABILITY

It might be argued that reliability is the most important quality that you should look for in a busway solution. There are several reasons for this:

First, for many data center owners, meeting the "three 9's" (99.9%), "four 9's" (99.99%) or even "five 9's of uptime" (99.999%) has become not just a goal, but a requirement. Enterprises and hyperscale companies know that any unplanned downtime can cost them tens of thousands of dollars per second in lost revenue. Wholesale data center and colocation providers build their reputations around Service Level Agreements (SLAs) that guarantee their ability to provide continuous uptime to their customers. The more reliable your power distribution is, the better equipped your data center will be to meet uptime obligations.

Second, the COVID-19 pandemic has forced many companies to rely more on online resources. Enterprise data center owners need to ensure that their IT systems will always be available, so their employees who work from home can continue to be productive. Internet, social media, and online business service providers need to ensure that their services will always be available to remote workers and home users. Colocation providers need to ensure the reliability of their customers' IT infrastructure, so that critical data and applications

hosted on IT servers housed in their colocation facilities will always be accessible.

Finally, over the next decade, many companies will deploy, utilize, and benefit from edge data centers. IT deployments on edge networks will often be housed in remote facilities with a small maintenance staff, or in unmanned modular or containerized data centers. With limited or no staff, these facilities will require a reliable power distribution system to ensure uptime of IT infrastructure, as well as efficient power monitoring to notify data center owners of any problems, maintenance issues, or sudden IT breaker shutdowns.

"A compression-fit joint between busway sections is the most reliable type of joint available, and is 100% maintenance free."

IMPORTANCE OF FLEXIBILITY

Power requirements in data centers are in a constant state of flux, as IT infrastructure is continuously deployed, scaled up, or reorganized according to the company's needs. Also, many large data centers are now upgrading their power systems at the rack level, from single-phase to higher-voltage (i.e. 400v or even higher) three-phase power. Facility owners need power distribution systems that can meet the ever-changing, ever-increasing power demands of their IT footprints.

You need a busway system that is easy to install and provides the flexibility of a customizable design to meet the layout of IT infrastructure within your facility. You also need a busway system that is adaptable to different power levels, allowing you to scale up as the power needs of your IT deployments change. And you need a

busway solution that allows for easy maintenance and replacement of parts.

Additionally, you should look for a busway solution with international certifications, one which can be supported and used in every part of the world (i.e. U.S/North America, Europe, Africa, Middle East, Asia, etc.).

IMPORTANCE OF SAFETY

Safety of equipment is paramount in the data center – first and foremost, to protect the workers who work there; secondly, to protect the IT infrastructure and the data that it processes; and finally, to protect the facility itself. As noted earlier, busway systems offer significant safety advantages over RPPs, and greatly reduce the risks of dangerous incidents, such as electrical shocks and arc flash explosions.

Data center owners have a responsibility to provide employees and electricians with the safest work environment possible. To this end, owners and CSEs should look for a busway solution that is designed for safety and is certified safe.

DESIGN ELEMENTS OF A BUSWAY SYSTEM

There are four primary elements that make up a busway system. These are:

- Track Busways
- Joints
- Plug-in Units (or tap boxes)
- Power Monitoring

In the following pages, we'll examine how the three qualities – reliability, flexibility, and safety – apply to each of these three element.

TRACK BUSWAYS

If a busway system is the “elevated highway” that allows electrical power to travel from the PDU to servers and racks, then individual track busway sections are the “straights and curves” that make up that “highway.” *Figure 1* shows the four types of busway sections:

- Straight Busways (a.) – The main busway sections that deliver power to the IT infrastructure.
- Elbow Sections (b.) – Used to make a horizontal, 90-degree turn in a run, by joining two straight sections.
- Tee Sections (c.) – Used to create a 90-degree branch leg, by connecting three different straight sections.
- Power Feed Units (d.) – A unit that supplies incoming power from the PDU to the busway. A power feed unit may also include power monitoring equipment, a serial, Ethernet, or Wi-Fi connection for reporting data, and an Infra-Red (IR) window for thermal scanning.

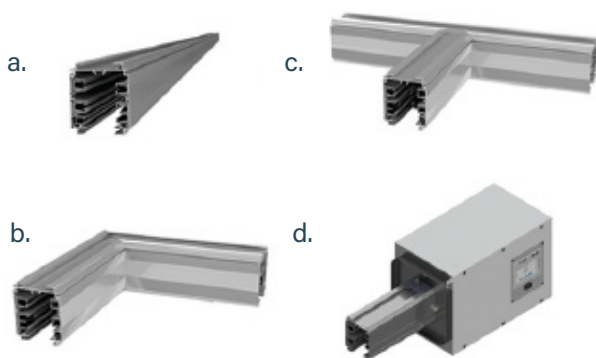

Figure 1

RELIABILITY

When evaluating a busway system, you should look for several features in the track busway sections that contribute to reliability. Each section should be made of high-grade engineered materials, with a lightweight aluminum housing and either 99% pure copper or copper-contact aluminum hybrid (for higher-power delivery) roll-formed busbars. The bottom should be an open, continuous access slot that runs the length of the busway section, allowing you to use the total available space to insert plug-in units.

The design of the internal busbars also makes a difference. The best design is a U-shaped busbar (*Figure 2*), which provides a continuous receptacle fitting for two types of connections: (1) a compression-fit joint to link busway sections together, and (2) a compression-fit electrical connection for the plug-in units in the busbar. (See the following sections of this white paper for more information.)

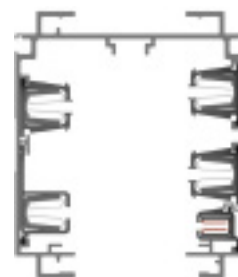

Figure 2

Finally, you should look for a busway solution that offers longer track busway sections, i.e. 3 to 6 meters (10 to 20 feet) in length. Since joints are often the main failure point in traditional busbar systems, having longer busway sections reduces the number of joints. Also, longer busway sections enable you to hang more plug-in units in a single busway section.

FLEXIBILITY

In a data center, existing infrastructure is often space-constrained. A track busway system should offer flexibility of design, allowing you to create system layouts that help you to make full use of your IT deployments.

The busway system should utilize not just straight busway sections of different lengths, but also elbow and tee sections. (Not every busway solution has these.) Also, the system should offer flexible options for where to place power feed units, including “end feed” units, which are installed on the end of the busway run, and “above feed” units, which are installed along the topside of the busway. (In some cases, utilizing tees and elbows can reduce the number of end feed connection points that you require.)

Additionally, you should look for a solution that offers busways with wide range of amperage options, with plug-in units being interchangeable between the range. A good range for continuous track busways is from 40 to 1200 amps. This will enable you to scale up your power delivery options easily as your power needs change over time.

SAFETY

You should look for a busway system that includes multiple provisions to deal with potential arc flash scenarios. The solution should have the following:

- Certifications from nationally-recognized test labs
- Selective coordination of fuses which, in the event of a power surge, allows the busway system to lower potential incident energy to negligible levels
- Arc flash certifications that include operator and equipment safety

- Industry-leading short circuit ratings
- An Ingress Protection safety rating of at least IP2X (“finger safe”) and, if possible, options for IP3X (“tool safe”)

Also, look for a busway system that gives you multiple ground path (earthing) options:

- Standard (protective) ground system – The busway’s aluminum housing provides the system’s ground.
- Isolated ground system – The ground conductor and the housing ground are isolated from each other in all components. (This can be useful for protecting certain types of IT loads.)
- Dedicated ground system – The ground conductor and housing ground are bonded together at the end power feed.

JOINTS

A joint provides a connection between adjacent busway sections, or between a straight busway and an elbow or tee section. Different busway providers use different types of joints. But you should look for vendors that utilize the most reliable kind of joint – a compression-fit joint. A compression-style joint kit (*Figure 3*) consists of (a) a bus connector – that is, copper blade busbars secured to an insulating mounting plate – and (b) a pair of housing couplers. The joint should be easy to install, but should have elements (i.e. plastic blockers in the housing couplers) that prevent it from being installed incorrectly.



Figure 3

When the joint is assembled (*Figure 4*), two busway sections are joined together. The bus connector is inserted into the access slot, and connected to the busbars at the joint area between sections. A special installation tool (provided by the vendor) is inserted at the intersection and rotated 90 degrees, to create a “knife blade” compression-fit joint.

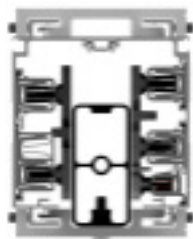

Figure 4

The busbar blades on the bus connector provide the electrical connection between busbars in the two adjoining sections. The two housing couplers are then used to connect the aluminum housing of the two sections at the top and bottom of the joint (*Figure 5*).

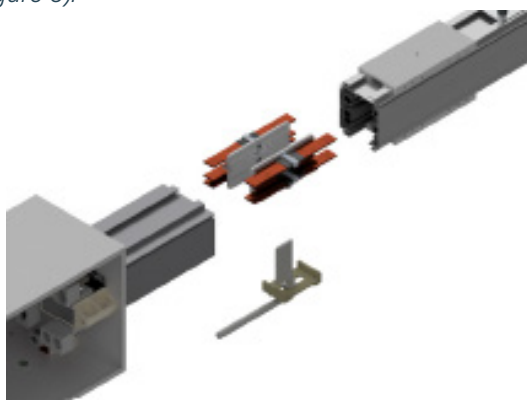

Figure 5

(With this kind of joint, the mechanical connection is entirely separate from the electrical connection. Even if the screws that secure the couplers become loose, the electrical connection between busbars will remain intact.)

The compression-fit joint has numerous advantages:

RELIABILITY

A compression-fit joint is the most reliable type of busway joint available. Failures of this type of joint are virtually unknown. Furthermore, the compression-fit joint is 100% maintenance free. Once it has been installed, no maintenance is required to preserve the joints between busway sections.

When the joint is installed, the “knife blade” compression-fit forms a solid electrical connection between busbars, and also “wipes away” any oxidation that might interfere with electrical conductivity, producing a 100% reliable connection every time. (Unlike other busway joints, a compression joint does not require copper grease to improve busbar connectivity or prevent oxidation.)

FLEXIBILITY

Joints are an essential element in flexibility of busway design, allowing you to link together track busway sections to form a busway run. What is important is to have a strong joint that works in tandem with the other elements to form a durable and dependable busway system.

SAFETY

The housing couplers in the joints carry ground conduction through the aluminum housing from busway section to section. It’s therefore important to find a busway solution with reliable, well-designed joints in order to properly maintain the ground conduction system.

PLUG-IN UNITS

The plug-in units (a.k.a. tap boxes) distribute the branch circuit power load from the busways to the servers, racks, or other equipment. Plug-in units (Figure 6) can be easily added or removed to the busway units as needed.



Figure 6

Here are the qualities that you should look for in busway plug-in units.

RELIABILITY

A plug-in unit should have a robust design with minimal moving parts, and the fewest electrical connections possible to deliver power to your critical load. The fewer moving parts the unit has, the more reliable it will be.

(The opposite is true as well. The more moving parts a plug-in unit has, the more prone to failure it is, and the more frequently IR testing (if this option exists) will be required to make sure it is operating properly. For this reason, you should avoid busway solutions that use plug-in units with an overly-complex design.)

THE PROBLEMS OF BOLTED AND MALE/FEMALE JOINTS

In selecting a busway system, you should avoid solutions where busway sections utilize bolted joints, which are less reliable than a compression-fit joint. In a bolted joint, bolts are used to press flat busbars together. Over time, the bolts can loosen, again resulting in a poor electrical connection. In a worst-case scenario, the joint can heat up to the burning point and potentially cause a fire in the data center.

Bolted joints must frequently be checked via thermal imaging, and re-torqued in order to maintain busway joint integrity. This adds to maintenance troubles and costs, especially in large data centers where thousands of bolted joints must be continuously serviced.

You should also avoid male and female joint couplings, which are easy to install incorrectly. The two busway sections must be perfectly aligned with each other, and a misaligned coupling can result in a poor electrical connection between sections. Conductive grease is often used between busbars in this type of connection to compensate for poor electrical conductivity, and to make the installation easier.

Due to the unique design of the male/female joint, if the mechanical coupling mechanism fails, the electrical connection will fail as well, since the mechanical and electrical connections are interconnected.

Also, a plug-in unit should have a simple paddle assembly as its electrical connection. When you insert this paddle into the busway, and turn it (Figure 7), the paddle's terminal stabs form a reliable compression-fit joint connection with the busbars. The plug-in unit should not rely on accessory mechanisms with springs and clips to make its electrical connection.

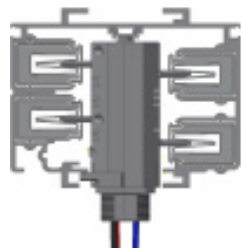

Figure 7

FLEXIBILITY

A busway solution should offer a wide range of plug-in units to handle different power demands and topologies. For example, if you decide to upgrade your power distribution at the rack level from single phase to three-phase power, you should be able to easily upgrade your busway system by buying new plug-in units to handle the increased power requirements. Additionally, plug-in units should be compatible for use with busways of different power levels (i.e. 250, 400, 1200 amps).

SAFETY

Safety of plug-in units is a primary concern, especially for facility engineers who often need to install tap boxes on live busways. At the most basic level, every plug-in unit from any vendor will have a grounding tab or device, which automatically grounds the unit prior to the electrical connection of the conductors into the busbars. However, you should look for a busway solution with additional safety features:

CALCULATING RELIABILITY

One method that you can use to statistically evaluate reliability in plug-in units is to compare the number of connections in the power chain. For example, engineers can calculate the difference between two and four electrical connections in a busway, each with the same connection reliability of 99%, through the following method:

$$0.99 \times 0.99 = \text{a } 98.01\% \text{ reliable connection}$$

$$[0.99 \times 0.99] \times [0.99 \times 0.99] = \text{a } 96\% \text{ reliable connection}$$

As you can see, even two additional connections will make a difference in the overall system reliability.

First, the design of the busway itself contributes to safety where plug-in units are concerned. An asymmetrical U-shaped busbar design makes it impossible to install a plug-in unit incorrectly. This in turn makes it impossible to cross live phases or ground paths when installing the plug-in unit into a live busway.

Also, you should look for a busway solution where the plug-in units come with optional safety accessories. These might include:

“Floor Operable” Electrical Connections – You can insert a plug-in unit into a live busway, step back to a safe distance, and use a hook stick to turn the unit, which connects the paddle to the busbar and makes the electrical connection.

Breaker Interlocks – A metal locking piece that prevents the unit from being installed or uninstalled while the breakers are on and the unit is under load.

Finger Shrouds – A plastic “shroud” cover that prevents the breaker switches on the unit from being turned off by accidental contact, i.e. during maintenance work on nearby server cabinets.

IR Windows – Infra-Red windows that allow for scanning of the plug-in unit’s internal power connections without performing hazardous work around live conductors.

“An asymmetrical U-shaped busbar design makes it impossible to cross live phases or ground paths when installing the plug-in unit into a live busway.”

POWER MONITORING

Today, many data center owners do power monitoring at the PDU and rack PDU level. But this is not enough. For a more complete package of data, and to ensure the reliability and safety of your entire power distribution system, you should look for a busway solution that allows you to do power monitoring at various points along your busway runs.

RELIABILITY

Look for a busway system that monitors and tracks both power and temperature data over time. It should have revenue-grade metering to ensure that all readings will be accurate and correct. This type of monitoring allows you to verify that busway runs are working properly, that joints are intact, and that servers and racks are operating at optimum power levels.

Power monitoring in the busway system can help you to balance your IT loads on each phase when utilizing three-phase distribution from the PDUs to the racks. It ensures that you don’t have one phase running at maximum load and two phases running at minimum load.

By monitoring and trending power and temperature data over time, you can identify potential issues before they happen, and schedule predictive maintenance. For example, if the monitoring system identifies a large temperature delta in an end feed unit, it may be time to perform scheduled maintenance and retorque the cable connections in the unit. Real-time temperature monitoring largely eliminates the need to do IR scanning.

FLEXIBILITY

A power monitoring system should have the ability to monitor up to six (6) single-phase branch circuits or two (2) three-phase branch circuits from the same meter. The plug-in units and end feed units should enable you to monitor and report power use at the rack PDU level, and over the entire busway run.

Also, a power monitoring system should offer flexible data reporting options, through wireless Ethernet (802.11), wired Ethernet, and/or serial communications. It should be able to simultaneously use all reporting protocols. Additionally, it should offer an embedded web page for access to system configuration or data, or easy integration with your Building Management System (BMS) or Data Center Infrastructure Management (DCIM) system.

SAFETY

A power monitoring system should have the ability to send out pre-set alarms in the event of a failure or emergency. For example, if a busway end feed rises to within 10 degrees of an unsafe temperature (i.e. ~85°C), the power monitoring system should have the ability to send an automatic email alert, or to provide that data to your BMS or DCIM, to warn you that a cable installation is potentially overheating and may cause a fire.

The monitoring system should also offer Breaker-Position Sensing, which allows you to monitor whether plug-in units are operating correctly. Again, the system should allow you to pre-set alarms, so if, for example, a plug-in unit suddenly shuts off, you will receive an automatic email alert, indicating that a server rack may have overheated and triggered the breaker.

WHAT YOU SHOULD LOOK FOR IN A BUSWAY SOLUTIONS PROVIDER

In choosing a busway system, you should take a close look at the provider as well. A busway provider should not be just a vendor, but a reliable business partner for your company. You should evaluate the provider using the following criteria:

EXPERIENCE

Your busway solutions provider should have years (preferably decades) of experience in busway design and manufacturing. The company should focus entirely on busway systems; it should be their specialty, and not just one of many items in their catalog of electrical products. The provider should be able to demonstrate longevity of product – that is, they should have a record of installing busway systems that are still operational after years of use by their customers.

Also, the provider should have a list of clients from a variety of different industries, such as data center and colocation providers, Fortune 500 companies, government organizations, industrial and manufacturing facilities, banks and investment firms, universities, and hospitals.

“Look for a busway solutions provider that will be a reliable business partner for your company.”

QUALITY RATINGS (METRICS)

A busway provider should have a series of quality ratings. (If the provider can't give you the following ratings for their company, you may want to look elsewhere.)

Six Sigma – The company should be able to provide their Six Sigma quality rating.

Shipments vs. Return Material Authorization (RMA) – The provider should have a high number of overall busway shipments vs. an extremely low number of returns due to product failure.

Mean Time Between Failure (MTBF) – The busway provider's products should have a long average time between failures. The higher the MTBF, the more reliable the product will be.

CUSTOM-DESIGNED BUSWAY SOLUTIONS

A busway provider should offer a range of highly configurable products and services. They should be able to help you identify busway designs that will fit the layout and needs of your specific data center or other facility. For example, they should be able to provide color-coordination of busway products (i.e. all track busways, end feeds, and plug-in units for Busway Run #1 are painted red,

while all similar elements for Busway Run #2 are painted blue), which can help to reduce or eliminate downtime due to human error.

Also, a busway provider should be able to engineer and manufacture customized products on demand according to your specialized needs. Engineers should be available worldwide to help design custom plug-in or end feed enclosures and busway systems that meet specific electrical ratings or size requirements. Furthermore, the provider should have a production lead time that fits your schedule, and should be able to complete orders in accordance with your deadlines for data center deployment, installation, commissioning, etc.

POST-SALES TECHNICAL AND ONSITE SUPPORT

A busway services company should provide the following:

- A global network of experienced sales representatives who can answer easy questions about their busway products
- A global services team of factory-certified technicians who can help you with onsite installation, commissioning, troubleshooting, and routine maintenance.
- A global engineering team ready to support specific projects
- 24/7 availability of technical support

CONCLUSION

For data center owners, CSEs, and others who are seeking power delivery solutions, the ultimate goal in selecting a busway system should be peace of mind. You want the certainty and confidence that your power distribution system will always be able

to deliver the power you need to your servers, racks, or equipment.

A reliable busway system is not just a power solution. It provides a competitive advantage, allowing your data center or other facility to stay operational. This ensures that your company will always be productive and able to deliver products or services to your customers. At the same time, it is essential to select a busway system that will guarantee the safety of your workers, with the flexibility to adapt to the layout and changing power needs of your facility. If you evaluate the elements of a busway system based on these three qualities – reliability, flexibility, and safety – and look for an experienced and highly-qualified provider who can also be a reliable business partner, you'll be able to choose a busway solution that will effectively serve your power distribution needs over the long run

ABOUT STARLINE

Starline is a global leader in power distribution equipment. For more than 30 years, Starline Track Busway has provided data centers with the most flexible, reliable, and customizable overhead power distribution systems on the market today. Other Starline products include the Critical Power Monitor (CPM), which works in conjunction with Starline Track Busway to improve energy efficiency; and Plug-In Raceway, the flexible, surface-mounted power distribution system.