

TRACK BUSWAY INSTALLATION, OPERATION, AND MAINTENANCE MANUAL



Starline[®]
A brand of **legrand**[®]

800T5 US SYSTEMS

REVISION REGISTER

Version	Details of Update	Date
1	Original document creation	04/15
2	Updated nomenclature, temporarily removed Product Selection Guide pages	06/16
3	Redesign; inclusion of Product Selection Guide pages	05/17
4	Updated Universal Global Services and warranty section	05/18
5	Redesign; Separation of US Domestic, Metric, and Global offerings	04/19
6	Redesign, separation of product selection guide pages, revised feed lug/torque reference chart	02/22
7	Updated storage and handling guidelines; hydrocarbon statement	05/24
8	Updated section 1: Production Specification installation 7.1.6; End Cap Installation	01/25

TABLE OF CONTENTS

SECTION 1: PRODUCT SPECIFICATION	3
SECTION 2: INSTALLATION INSTRUCTIONS.....	13
US Installation Instructions.....	14
Feed Reference Chart.....	16
Ground Options.....	17
800T5 End Feed Installation.....	18
800T5 Joint Kit Installation.....	19
Hanger Bolt Installation.....	20
800T5 End Cap Installation.....	21
SECTION 3: PLUG-IN INSERTION INSTRUCTIONS	23
Installing a Plug-In Unit.....	24
Removing a Plug-In Unit.....	27
Plug-In Distance Clearances	28
SECTION 4: FIELD SERVICES AND WARRANTY.....	35
Starline Services.....	36
Standard Factory Warranty.....	39
Standard Factory Warranty Process.....	39
SECTION 5: MAINTENANCE.....	41
Starline Busway Recommended Maintenance	42

1

Section 1: Product Specification

BUSWAY SYSTEM

1 SUMMARY

- 1.1 This specification covers the electrical characteristics and general requirements for a track busway system, hereafter referred to as Track Busway. The system shall be designed primarily for overhead power distribution of electrical power. Once installed, the Track Busway will provide simple, versatile, fast and economic means of distributing power. Loads fed from Track Busway plug-in units can be added or removed without shutting down the busway.
- 1.2 Specification includes:
 - 1.2.1 Three-phase Track Busway system with the following features:
 - 1.2.1.1 Extruded aluminum busway housing with conductors
 - 1.2.1.2 Power Feed
 - 1.2.1.3 Plug-in units for power distribution
 - 1.2.1.4 Monitoring
 - 1.2.1.5 Installation tool and joint kits
 - 1.2.1.6 Optional accessories

2 STANDARDS AND CERTIFICATION

- 2.1 The Track Busway shall be designed and manufactured to the following standards:
 - 2.1.1 Electrical Testing Laboratories (ETL) (US/Canada) Certified to UL 857.
 - 2.1.2 CCC (China) Certified to GB 7251.1-2013.
 - 2.1.3 CE (Europe) Certified to IEC 61439-1 and IEC 61439-6.
 - 2.1.4 NOM (Mexico) Certified to NOM-003-SCFI-2000
 - 2.1.5 National Electric Code (NEC) – Article 368 – Busways
 - 2.1.6 National Fire Protection Agency (NFPA) – 70, National Electric Code (NEC)
 - 2.1.7 National Electrical Manufacturers Association (NEMA) – AB1, Molded Case Circuit Breakers and Molded Case Switches (*if applicable*).
 - 2.1.8 National Electrical Manufacturers Association (NEMA) – KS-1, Enclosed and Miscellaneous Distribution Equipment Switches (600 VAC) (*if applicable*).

3 SYSTEM DESCRIPTION

3.1 Electrical Requirements

3.1.1 System voltage: 600V

3.1.2 Frequency: 50/60 Hz.

3.1.3 Ampacity: 800

3.1.4 Neutral Ampacity: Minimum of 100% of rating

3.1.5 Short circuit

3.1.5.1 65kAIC up to 600V (hybrid system); 35kAIC up to 600V, 50kAIC up to 480V (copper system).

3.1.6 Conductors: 3 phase conductors, 1 neutral conductor solid copper, tin plated.

3.1.7 Grounding: Aluminum casing or 1 dedicated conductor solid copper, tin plated.

3.2 Operational Requirements

3.2.1 Environmental Conditions: The Track Busway shall be capable of operating continuously in the following environmental conditions without mechanical or electrical damage, degradation or derating of operating capability.

3.2.1.1 Busway shall operate with continuous load with no derating up to 40 degrees Celsius, 0.95 multiplier at 45 degrees C., 0.90 multiplier at 50 degrees C, 0.85 at 55 degrees C and 0.825 at 60 degrees C.

3.2.1.2 Relative humidity: 0 to 95 percent, noncondensing.

3.2.1.3 Altitude: Sea level to 6600 feet (2000m).

3.2.2 Storage and Handling Guidelines: The Track Busway shall be stored in accordance with the manufacturer's recommendations and the following standards. Reference Storage Guidelines: IEC 61439-1, Part 7; IEC61439-6; NEMA Standards Publication BU 1.1, Section 5 (Storage).

3.2.2.1 Temperature: busway shall not be stored in temperatures below -20 degrees Celsius and above 35 degrees Celsius.

3.2.2.2 Relative Humidity: shall not exceed 70%, non-condensing for lower temperatures. Condensation can be prevented or dried at low temperatures by warming the busway above the dew point.

3.2.2.3 Storage: Stored in an environment that is free of debris, dirt, fumes, water and physical damage. It is recommended that busway should not be stored outdoors.

3.3 Manufacturers Qualification

3.3.1 A minimum of 10 years' experience in the manufacturing of the busway products.

3.4 Manufacturing Requirements

3.4.1 All Track Busway components and accessories shall be manufactured by Starline Holdings, LLC.
Starline Holdings, LLC
168 Georgetown Rd.
Canonsburg, PA 15317
(724) 597-7800

4 SUBMITTALS

4.1 Submittals shall be in accordance with specified procedures. Submit shop drawing and product data for record purposes prior to shipment. Shop drawings for Track Busway must include:

4.1.1 Detailed equipment assemblies and dimensions, weights, location and identification of each field connection.

4.1.2 Wiring Connection: For power and monitoring wiring.

4.1.3 Orientation of plug-in units face in final installation.

4.1.4 Include plug-in schedule with detailed description.

4.2 Provide electrical characteristics and connection requirements for the system and accessories.

4.3 Indicate special receiving and handling procedures.

5 WARRANTY

5.1 The Track Busway manufacturer shall guarantee the entire system against defective material and workmanship for a period of one (1) year from date of shipment.

5.2 Additional years of warranty and ability for start-up services must be an option if required per drawings.

5.3 Warranty shall only cover Track Busway product components manufactured by Starline Holdings, LLC; use of any aftermarket components with Track Busway shall void warranty and any certifying listings completely.

6 PRODUCT COMPONENTS

6.1 Track Busway Housing

6.1.1 Extruded aluminum housing certified to serve as a 100% ground. Standard housing lengths are 5 and 10 feet (1.5 and 3 meters). The housing should be properly extruded with a slot to receive rod mount hangers to hang from a ceiling. This housing should be open on the bottom to accept plug-in units anywhere along its length. This opening shall pass UL's hypothetical finger probe test.

6.1.2 All conductors shall be made of copper, and sized to handle 100% of its rating continuously up to

the maximum ambient temperature. The conductors shall be electrically isolated from the housing. All insulators must be UL and IEC compliant.

6.1.2.1 Ground conductor: An internal, 100% ground conductor is to be supplied if shown on the drawings.

6.1.3 Track Busway housing sections shall be joined together by a 'press fit' that requires no bolted connection and no future maintenance.

6.1.4 Track Busway T5 series shall have an included data channel built into the housing to accommodate optional, color-coded data cabling accessories.

6.1.5 Track Busway housing shall be available in standard silver, red, blue, black, white or custom RAL colors.

6.1.6 Starline conductor insulation systems are produced using performance polymer materials. Therefore, it should be noted that Starline strongly advises against the use of hydrocarbon based products found in commonly used release sprays & cleaning fluids, due to potential non-compatibility.

6.2 Power Feed

6.2.1 The power feed shall provide the connections from the incoming cables to the Track Busway system. The power feed shall have internal connection to a section of busway conductors. End feeds, top feeds, center feeds and bottom feeds shall be available depending upon what Track Busway system is required. Feeds shall have the option to be designed with mechanical or compression type lugs.

6.3 Plug-In Units

6.3.1 Plug-in units shall be polarized to avoid incorrect installation.

6.3.2 Plug-in units can be added, removed or repositioned without de-energizing the busway.

6.3.3 Plug-in units shall use either a circuit breaker or a fuse for branch circuit protection as shown in the schedule on the project drawings.

6.3.4 Plug-in units shall be capable of being built with customer-specified circuit protection, outlets and accessories.

6.3.5 Plug-in units shall have a soldered wire connection on each stab that picks up power from the busway. This wire shall then be directly connected to the line side of the circuit breaker. The use of crimp connectors is prohibited.

6.3.6 Plug-in units shall not require any tools to mount to the busway.

6.3.7 Plug-in units shall not have a mechanism in order to engage the electrical connection to the busway conductors.

- 6.3.8** Plug-in units shall have locking clips or bolt-on tabs to secure units to the busway.
 - 6.3.9** Plug-in units that include drop cords shall be manufactured with cord grips and receptacles as specified in the drawings.
 - 6.3.10** Plug-in units shall be configured by the manufacturer to balance the load based on quantity of plug-in unit types provided.
 - 6.3.11** Plug-in units shall have the ability to provide up to a 600 amp load in certain plug-in unit configurations.
 - 6.3.12** Plug-in units shall have a minimum of 10kAIC and the ability to obtain a maximum of 200kAIC.
 - 6.3.13** Plug-in units shall be interchangeable within each Track Busway series (T1, T2, T3, T5).
 - 6.3.14** Plug-in units shall be available with optional, revenue grade metering devices.
 - 6.3.15** Plug-in units authenticity shall be proven by the presence of a Starline ratings label.
- 6.4** Accessories (*OPTIONAL*)
- 6.4.1** Closure strip and access panels shall be available for conductor access points to minimize accidental contact or build-up of debris.
 - 6.4.2** Integrated cable management solutions as part of the aluminum housing (T5 series), capable of handling accessories such as the data channel cover, hinged wire way, data cable strap, and multi-use mounting bracket.
 - 6.4.2.1** Data channel covers are color-coded for integrated cable management solutions.
 - 6.4.3** Universal Server Cabinet Mounting Brackets shall be available as an alternative hanging solution; meant for mission critical applications.
- 6.5** Monitoring (*OPTIONAL*)
- 6.5.1** Power Feed Monitoring: The power feed is to be provided with the following power measurements and remote monitoring interface:
 - 6.5.1.1** Input Voltage (L/L and L/N)
 - 6.5.1.2** Current per Phase (Min/Max)
 - 6.5.1.3** Voltage per Phase (Min/Max)
 - 6.5.1.4** Neutral Current
 - 6.5.1.5** Power Factor
 - 6.5.1.6** Frequency

- 6.5.1.7 Power (Active, Reactive, Apparent)
 - 6.5.1.8 Demand (kWH)
 - 6.5.1.9 Current Peak Demand
 - 6.5.1.10 End Feed Lug Temperature
 - 6.5.1.11 Communications is HTTPS, SSH, SNMPv1, SNMPv2c, SNMPv3, BACnet, Modbus TCP, Modbus RTU, Ethernet (Daisy Chain).
 - 6.5.1.12 Optional wireless
 - 6.5.1.13 LCD colored, 4.9 inch (125mm) display.
- 6.5.2 Plug-In Unit Monitoring: The plug-in units as indicated on the schedule on the project drawings shall have the following power measurements and remote monitoring interface.
- 6.5.2.1 Input Voltage (L/L and L/N)
 - 6.5.2.2 Current per Phase (Min/Max)
 - 6.5.2.3 Voltage per Phase (Min/Max)
 - 6.5.2.4 Power Factor
 - 6.5.2.5 Frequency
 - 6.5.2.6 Power (Active, Reactive, Apparent)
 - 6.5.2.7 Demand (kWH)
 - 6.5.2.8 Current Peak Demand
 - 6.5.2.9 Accuracy is better than 0.5%
 - 6.5.2.10 Communications is HTTPS, SSH, SNMPv1, SNMPv2c, SNMPv3, BACnet, Modbus TCP, Modbus RTU, Ethernet (Daisy Chain).
 - 6.5.2.11 Optional wireless plus available daisy chain Ethernet topology.
 - 6.5.2.12 Optional display

7 INSTALLATION

- 7.1 The contractor shall install Track Busway in accordance with the manufacturer's instructions.
 - 7.1.1 Track Busway runs shall consist of lengths as shown on the drawings.
 - 7.1.2 The plug-in unit orientation shall be indicated on the drawings.

- 7.1.3** Hanging of the Busway: The Track Busway shall be hung from a structure above the busway, using the supplied busway hangers. The hangers shall connect to the busway, and to an all thread rod provided by the installing contractor. The spacing of the hangers along the busway is 10 feet (3 meters).
- 7.1.4** The busway shall be installed with the open access channel facing downward, or to the side for special applications. Special installation shall be agreed upon by the manufacturer.
- 7.1.5** Connecting Sections of Track Busway: At a junction of Track Busway sections, the installer will use a Joint Kit (includes Housing Couplers and Bus Connector) and an Installation Tool supplied by the manufacturer. Two sections are joined together by a 'press fit' that requires no bolted connection and no future maintenance.
- 7.1.6** End of Runs: End caps will be provided to install at the end of each run. Before installing, the installer shall inspect the end of each busway section to ensure that busway retainer clips are present and installed properly. Each clip should be glued flush into the busway insulator, providing a minimum clearance of 1 in. between the end of the insulator and busway conductors.
- 7.1.7** Closure Strip: The closure strip is an optional accessory that can be cut and fitted to cover the bottom opening of the Track Busway housing to prevent dust and debris. Closure Strip can be field modified for fit.

7.2 All Track Busway joints are non-bolted, compression fit and shall require no maintenance after installation.

8 FIELD QUALITY CONTROL

- 8.1** Manufacturers Field Services: Track Busway shall be accompanied by optional services, such as onsite support and system startup, ongoing support, metering services and extended warranty programs. These services include:
 - 8.1.1** On-site Training
 - 8.1.2** Installation Inspection, Commissioning and Certification
 - 8.1.2.1** Includes comprehensive visual inspection and certified report once results are satisfactory, which extends standard factory warranty from one to two years.
 - 8.1.3** Load Bank Testing
 - 8.1.4** IR Scanning and other Ongoing Support
 - 8.1.5** Extended Warranty Programs (Meter programming, commissioning and support).
 - 8.1.6** 24/7 Emergency Service and Phone Support.

9 DOCUMENTATION

- 9.1** The following documentation shall be available to assist in product selection and installation, and is available for download at <https://downloads.starlinepower.com/>:

- 9.1.1** Track Busway Product Selection Guide
- 9.1.2** Operation, Installation and Maintenance Manuals
- 9.1.3** Installation Instructions
- 9.2** Product drawings shall be rendered and provided at the time of ordering.

800T5 US SYSTEMS

PRODUCT SPECIFICATION

Section 2: Installation Instructions



800T5 US SYSTEMS

INSTALLATION INSTRUCTIONS

U800

Starline® Busway Installation Instructions:

Busway supports (e.g. threaded rod, Unistrut®, etc) are supplied by customer. The maximum spacing between supports/hangers is 10ft. The most common hangers are shown in this instruction but other hangers are available to suit most situations (see catalog).

Tools needed: ST5IT installation tool, 1/8 in hex wrench, slotted head screw driver and/or angled pry bar, and dead blow hammer/rubber mallet. Two or more persons and/or a mechanical lift are recommended to install Starline Busway.

Mechanical Installation

1. Begin installation at one end of the busway, preferably at the location of the supplied power source.
2. If an end feed box is used, ensure the polarizing stripe on the busway section matches the end feed busway stub. End feed box can be attached to the adjoining busway section before or after the busway section is installed on the supports.
3. Attach the hanger bolts to busway supports. Prior to sliding the supports into the busway hanger channel, insert one SBHC600800T5-1 housing coupler into the top and bottom channels on one housing. Slide the supported hanger bolts into the busway hanger channel. Once in position, secure the supports by tightening the hanger bolts. Install additional section(s) in a similar manner. Note: The housing couplers and hanger channels of the busway are keyed, so the couplers can only be inserted one way.
4. Join the two adjacent busway components (e.g. straight-to-straight, straight-to-elbow) together by positioning only the top housing coupler an equal distance across the two sections. Tighten the set screws securely.
5. The connector bodies are keyed and labeled: L2-L1-GND goes into the polarized side and L3-N goes opposite the polarized side. Insert one of the SBC800T5x-1 connectors into the housing slot. Ensure it is facing the correct side of the busway section and it is centered on the joint. Line up copper blades with the conductors.
6. Insert the installation tool ST5IT into the housing slot at the joint location, then position the tool collar around the busway housing. Make sure the radius of the tool blade is against the bus connector body.
7. Using the lever, rotate the installation tool to press the connector into the busway conductors. Work from one end of the connector body to the other until the copper blades are fully seated into the conductors.
8. Once the first connector is installed, insert the second connector into the housing opposite the first. Install as previously described.
9. To complete, center the bottom housing coupler between the two sections. Tighten the set screws on the top and bottom couplers to 60 in-lbs. Repeat the previous steps until busway run is complete.
10. If installing elbows or tees, check to make sure that you have the appropriate elbow or tee for the direction of travel. Refer to the illustration on right.
11. Install one SEC800T5 end cap at any open end of the busway run and tighten the set screws to secure it in place.

Electrical Installation

The end feed and/or above feed (not shown) units are used to make field wiring connections to the busway. Wiring connections are made to the copper blades by means of aluminum box style lugs or compression lugs installed onto the supply cables. For all versions, safety ground connections are made to the box with the lug provided. Isolated ground systems provide a separate, additional connection.

Warning: Make sure the power is off before making your wire connections inside the end feed box.

1. Remove side/top cover(s) as necessary from end/above feed. Drill, punch, etc. holes as needed and attach conduit fittings, etc. Feed wires into end/above feed.
2. If using mechanical lugs, remove the lug for a given phase from the end feed block, attach wire to lug and reinstall back on block. In some cases it may be possible to install wire into the lug without removing the lug from the block. If using compression lugs installed onto cables, remove bolt(s) from end feed block and connect compression lugs/cables directly. End feed units will accept up to 600MCM cable. Secure by tightening the set screw to specified torque shown on label inside end feed. Repeat for the remaining connections.
3. Do not move plug while paddle is engaged in busway.

Notes:

1. The aluminum housing is listed by UL for use as a ground conductor. The plug-in units that are bolted to the Busway can be grounded through the housing. Extension of this ground to the customer's equipment should be done in a manner to comply with the National Electric Code.

Starline® Top Boxes are the only acceptable top boxes or plug-in devices for use in Starline® Busway.

UBHT5-1
Hanger Bolt
(Not Shown)

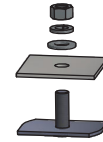

UBRHT5-1
UBRHT5-2
Rod Hanger Bolt
(Item 3)

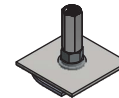

SBHC600800T5
Housing Coupler

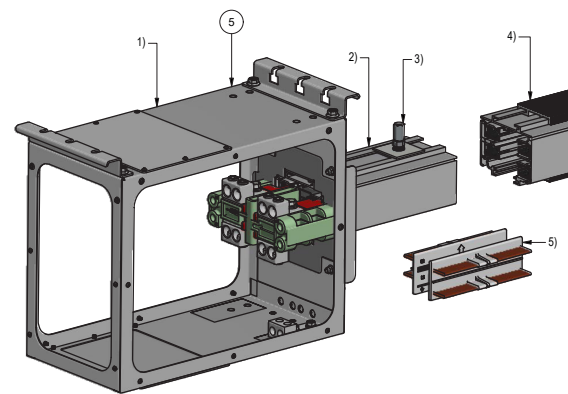
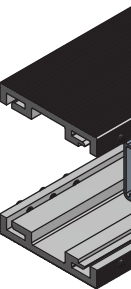

ELBOWS

NTS

TEES

US800T5H4S-0500P
U.S.
STRAIGHT SECTION
PRODUCT FRAME
COMPATIBILITY
MATERIAL - HYBRID (Cu/Al)
ACCESS PANELS
5'-0"
POLARIZATION (STANDARD)
NEUTRAL/GROUND BUSBAR
4 - (3 PHASE PLUS NEUTRAL)

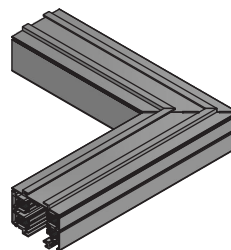

UE800T5xxS-EX
External Elbow
UE800T5xxS-IN
Internal Elbow
(Items 4)

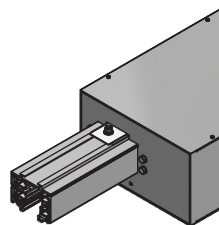

800T5 US SYSTEMS

INSTALLATION INSTRUCTIONS

INSTALLATION INSTRUCTIONS

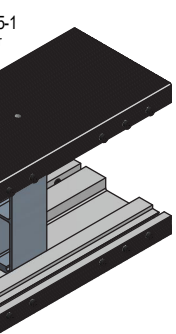

SJKxxxT5x-2
Joint Kit (Item 2)

Each joint kit contains a housing coupler pair (SBHC600800T5-1) and Bus connector set (SBC800T5x-1)

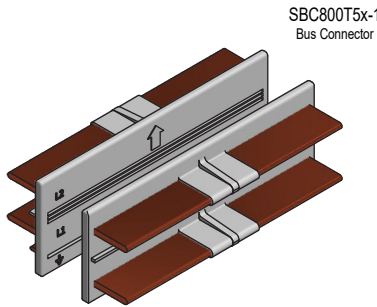

SBC800T5x-1
Bus Connector

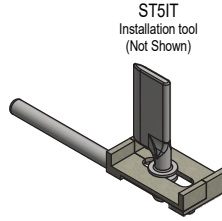

ST5IT
Installation tool
(Not Shown)

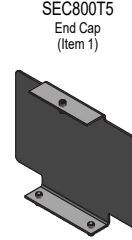

SEC800T5
End Cap
(Item 1)

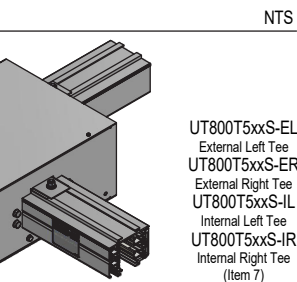
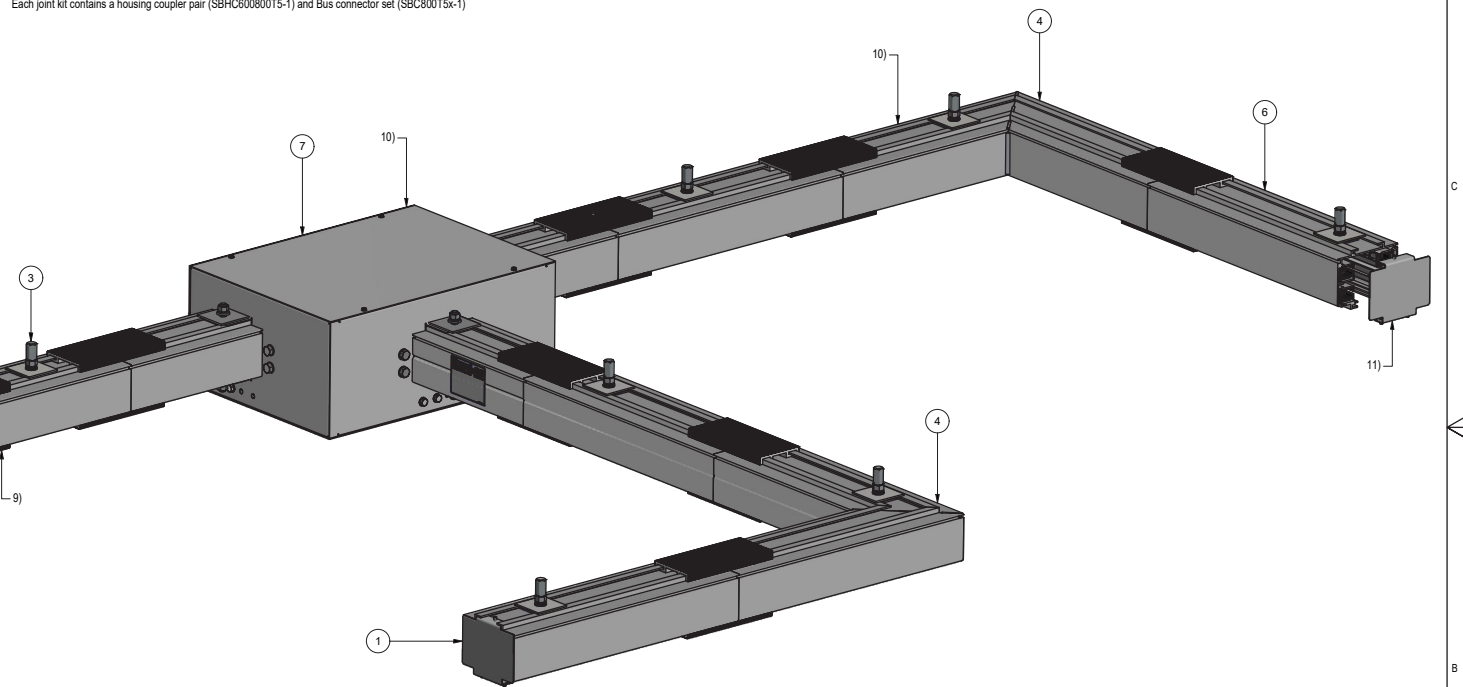

NTS

UT800T5xxS-EL
External Left Tee
UT800T5xxS-ER
External Right Tee
UT800T5xxS-IL
Internal Left Tee
UT800T5xxS-IR
Internal Right Tee
(Item 7)

CROSS SECTION

1:2

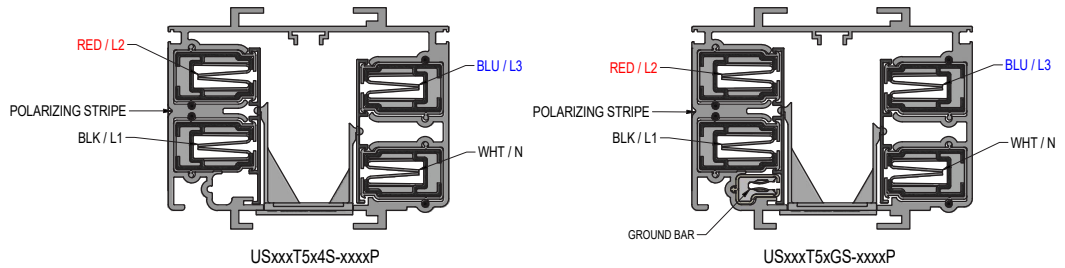

NOTICE TO PERSONS RECEIVING THIS DRAWING AND/OR TECHNICAL INFORMATION: STARLINE CLAIMS PROPRIETARY RIGHTS TO THE MATERIAL DISCLOSED THEREON. THIS DRAWING AND/OR TECHNICAL INFORMATION IS ISSUED IN CONFIDENCE FOR ENGINEERING INFORMATION ONLY AND MAY NOT BE REPRODUCED OR USED WITHOUT DIRECT WRITTEN PERMISSION FROM STARLINE.

Cutting Tolerances	Revision History			
	REV	ISS	DATE	REV BY
Component Length ±.24" ±.030" >.24" ±.063" >120" ±.125"	C	ECO 18485	10/1/2020	festler
	B	ECN 16679	10/22/2019	jminard
	A	Original Issue	8/26/2016	eschultz
			7/7/2016	tmorgan

F4006100

1 OF 1
C

FEED REFERENCE CHART

(M/U)F800 'B' BOLT LUGS
 WHEN COMPRESSION LUGS ARE USED TORQUE TO 675in.-lbs / 76 Nm

(M/U)F800 'S' MECHANICAL LUGS
 600 MCM - 2 AWG
 300 mm² - 35 mm²
 MAX 2 - CONDUCTOR

(M/U)F800 'D' DOUBLE MECHANICAL LUGS
 600 MCM - 2 AWG
 300 mm² - 35 mm²
 MAX 4 - CONDUCTOR

(M/U)F800 'Q' QUAD BOLT LUGS
 WHEN COMPRESSION LUGS ARE USED TORQUE TO 675in.-lbs / 76 Nm

(800A-1200A) ENCLOSURE GROUND FOOTPRINT
 1X UNTERMINATED LUG LANDING PAD
 INTENDED FOR FIELD PURCHASED LUGS
 (MECHANICAL OR COMPRESSION)

(800A-1200A) CHASSIS GROUND
 350 MCM - 6 AWG
 180 mm² - 16 mm²
 MAX 2 - CONDUCTOR

(250A-1200A) ISO/DEDICATED GROUND
 300 MCM - 6 AWG
 150 mm² - 16 mm²
 MAX 1 - CONDUCTOR

NOTE:
 1. TORQUE INFORMATION IN THIS DOCUMENT REFLECT THE VALUES RECOMMENDED BY STARLINE. CONTACT YOUR LOCAL STARLINE APPLICATIONS ENGINEER FOR QUESTIONS OR ADDITIONAL INFORMATION.
 2. INFORMATION IN THIS DOCUMENT WILL INCLUDE INFORMATION ON STARLINE'S STANDARD FEED ASSEMBLIES. FOR CUSTOM END FEED UNITS, CONTACT YOUR LOCAL STARLINE APPLICATIONS ENGINEER FOR INFO.
 3. FEEDS HAVE BEEN DESIGNED TO MEET MINIMUM CLEARANCE OF 1/2" BETWEEN PHASE AND GROUND AND 1" BETWEEN PHASE AND PHASE. THESE CLEARANCES ARE REQUIRED AFTER FIELD TERMINATIONS ARE LANDED AND INSTALLATION IS COMPLETE.
 4. TORQUE VALUES LISTED COMPLY TO MEET WITH TEST STANDARDS UL 837 AND IEC 61439.

ENCLOSURE COLOR DESIGNATION		CUTTING TOLERANCES		CONDUCTOR LEGEND	
B	ECO-19803	1/16"	0.0015"	ENCLOSURE	1/2"
A	ECO-19805	1/16"	0.0015"	TERMINAL	1/2"

GROUND OPTIONS

FAQ CASE GROUND, DEDICATED GROUND, ISOLATED GROUND

CASE GROUND

Uses aluminum housing and no extra copper bar.

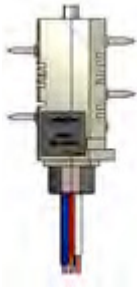

T5

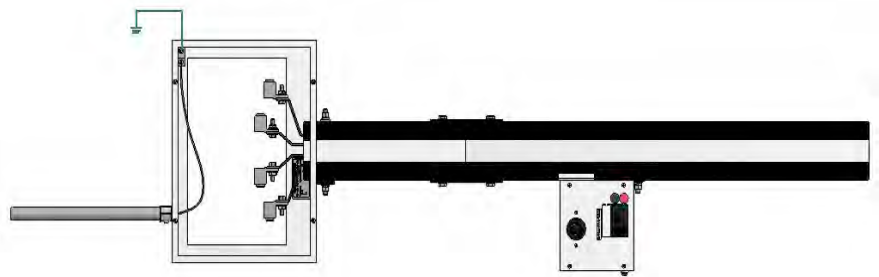

DEDICATED GROUND

Extra bar in busway for ground. Everything tied together inside plugs. Bar and housing at same potential.

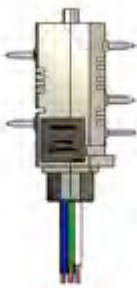

T5G

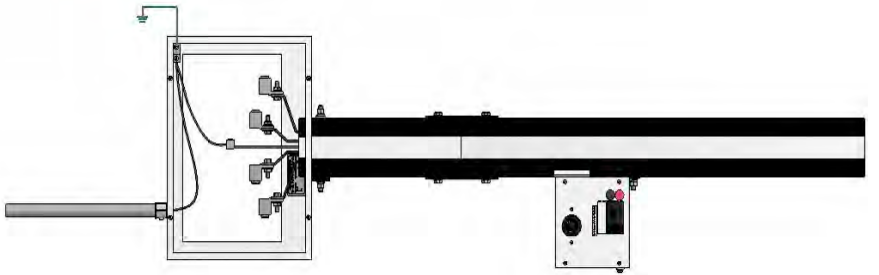

ISOLATED GROUND

Orange receptacles in plugs. Case ground isolated from copper ground bar. Isolated ground carried back to panel by others.

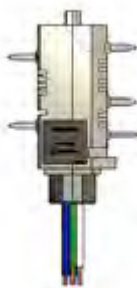

T5 G

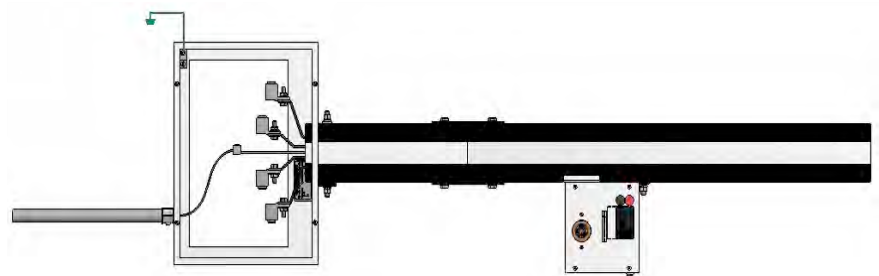

800T5 END FEED INSTALLATION

Warning: Make sure the power is off before making your wire connections inside the End Feed Box.

End feed units are used to make field wiring connections to the busway at the end of a run. The end feed box installs like a standard section. Wiring connections are made to the copper blades by means of aluminum box style lugs. For all versions, safety ground connection is made to the box with the lug provided. Isolated ground systems provide a separate, additional connection. The end feed box can be installed on the busway section before or after hanging the busway.

End feed boxes can be supported with a variety of hanger options, including gland plates and hangers which are approved for seismic zones. End feeds can also be encased in Unistrut cradle and suspended with threaded rod. See product selection guide for list of end feed support accessories. Drilling through the end feed housing is not recommended due to debris and the potential for violating electrical creepage and clearance.

Field Wiring

Remove the lug from the end feed block. Attach wire to lug. Reinstall back on block. In some cases it may be possible to install wire into the lug without removing the lug from the block. The lug is capable of accepting up to 2 600MCM cables. Reference the above feed lug capability chart for lug sizes and torque values.

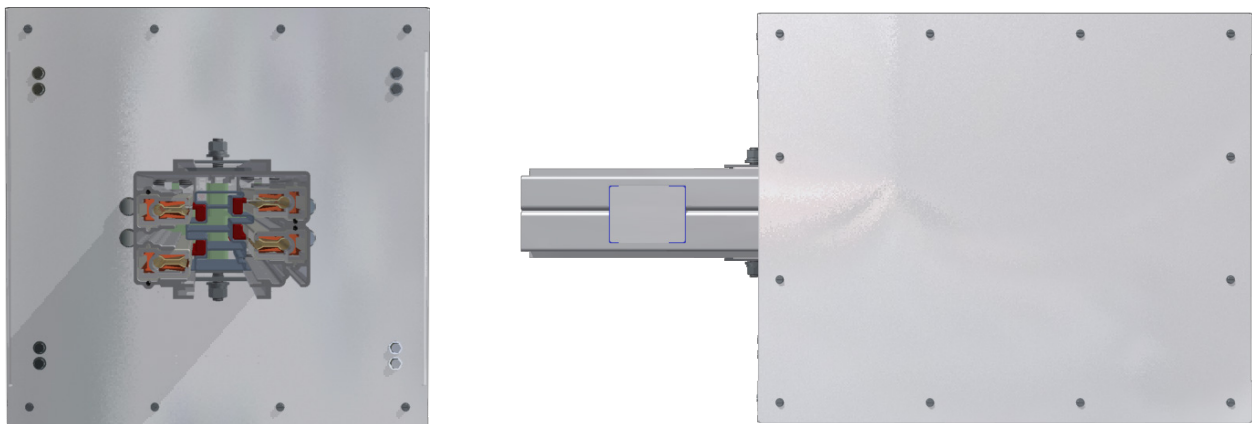

800T5 JOINT KIT INSTALLATION

For connection of adjacent Busway sections. One Kit is required at each joint. Each Kit is comprised of a housing coupler pair and bus connector set. Specify configuration to match busway configuration.

Insert the pair of Housing Couplers onto one housing section. The housing coupler and the hanger channel of the Busway are polarized; ensure they are aligned before inserting them. Position the bottom coupler away from the joint, and align the Busway with the adjacent Busway section. Center the top housing coupler around the joint and tighten the set screws securely. Next, begin to install the bus connector kit by inserting the A-B Bus Connector inside the slot of the Busway. Ensure the connector is centered on the joint and push the Bus Connector in until secure. Insert the installation tool inside the slot of the Busway at the joint. Position the collar around the Busway housing so that the radius on the tool is positioned against the Bus Connector cover. Using the lever, rotate the installation tool and release. Work toward the end of the blade cover until the copper blades are firmly seeded into channels.

Repeat each of these steps for the other side of the Bus Connector. Remove the installation tool, center the bottom housing coupler, and tighten the 24 set screws.

For further assistance, refer to the installation video here:

<https://youtu.be/dosAdBP0txk>

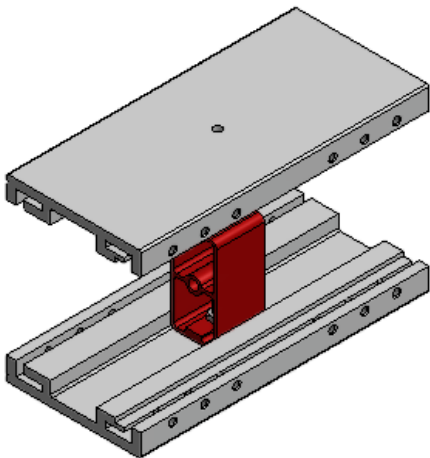

Figure 1: Housing Coupler

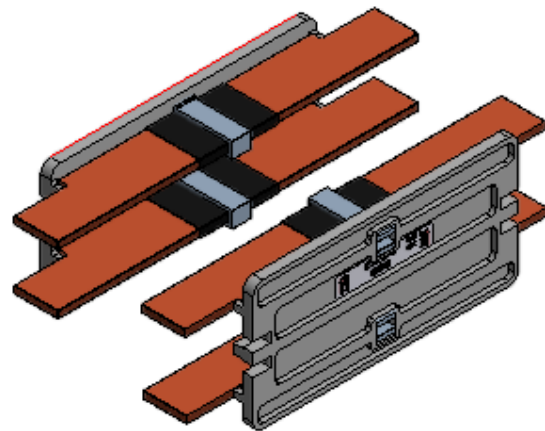

Figure 2: Bus Connector

HANGER BOLT INSTALLATION

There are two standard hanger options for mounting Starline Busway. UBRHT5-1 (Figure 1) is the standard hanger for supporting Starline busway via 1/2" threaded rod. UBHT5-1 (Figure 2) is most commonly seen when hanging via unistrut. At a minimum, 10 ft. (3m) intervals support the busway via support hardware. Once the hanger is placed in the mounting channel and the support hardware is installed, tighten down with 1/2" wrench. UBSHT5-4 (Figure 3) is a one piece slotted hanger compatible with 1/2 -13 UNC threaded rod. Hanger Bolt UBRHT5-2 (Figure 4) is used for support in Gordon Grid applications. UBRHT5-3 (Figure 5) is intended for use in Seismic applications.

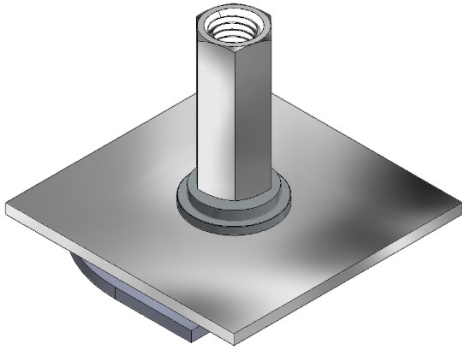

Figure 1: UBRHT5-1

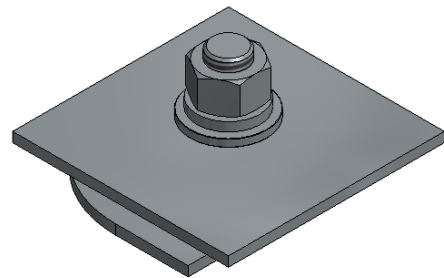

Figure 2: UBHT5-1

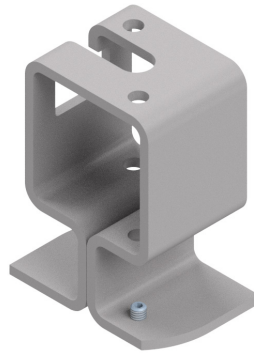

Figure 3: UBSHT5-4

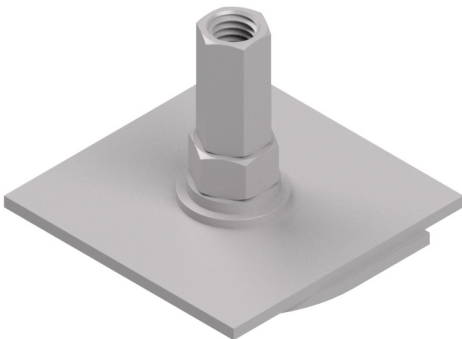

Figure 4: UBRHT5-2

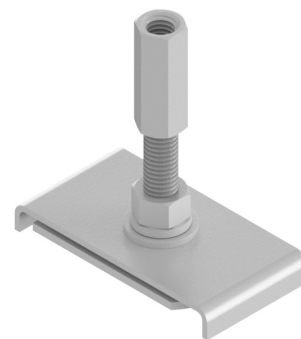

Figure 5: UBRHT5-3

800T5 END CAP INSTALLATION

End caps are used to close the exposed endings of busway sections. Each termination point on a busway system must have an end cap.

To install, seat the end cap at the exposed end of the busway section. With a Hex Key, tighten the set screw at the top of the end cap against the busway until it is secure.

Please note:

Before installing, the installer shall inspect the end of each busway section to ensure that busway retainer clips are present and installed properly. Each clip should be glued flush into the busway insulator, providing a minimum clearance of 1 in. between the end of the insulator and busway conductors.

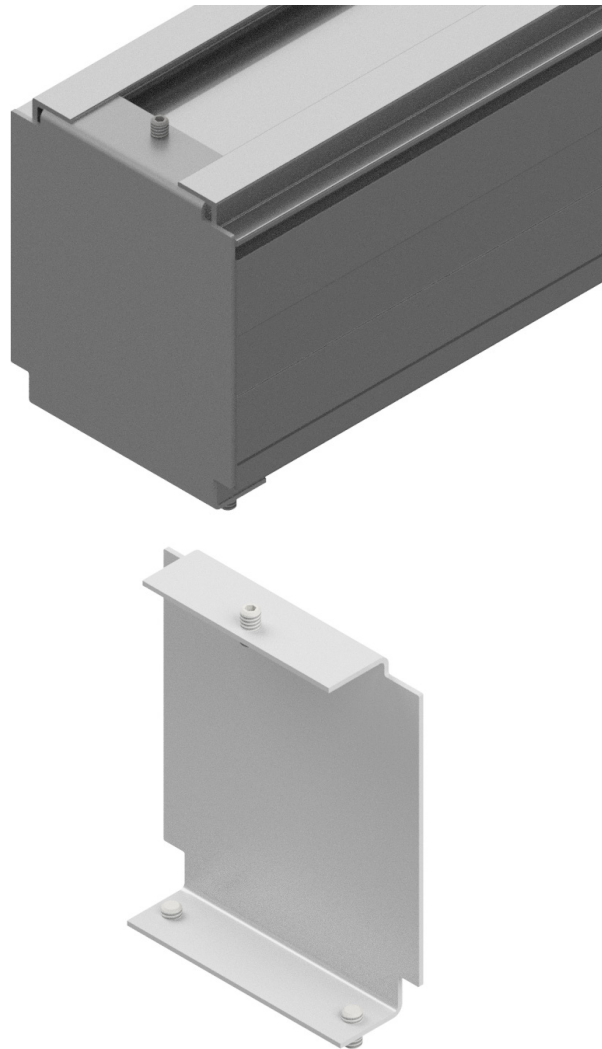

800T5 US SYSTEMS

INSTALLATION INSTRUCTIONS

Section 3: Plug-In Insertion Instructions

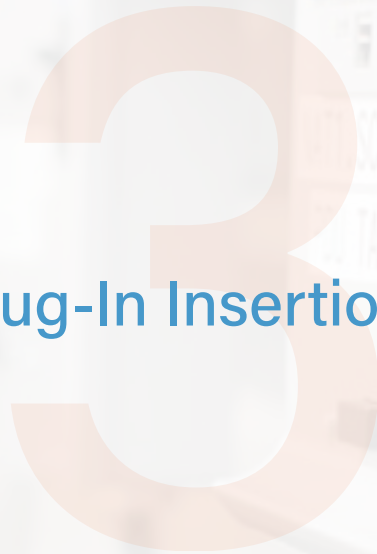

INSTALLING A PLUG-IN UNIT

Before You Begin

- Always wear appropriate PPE
- Please consult your local electrical code for information on calculating incident energy for the location of your work, and the necessary associated PPE for your particular installation.

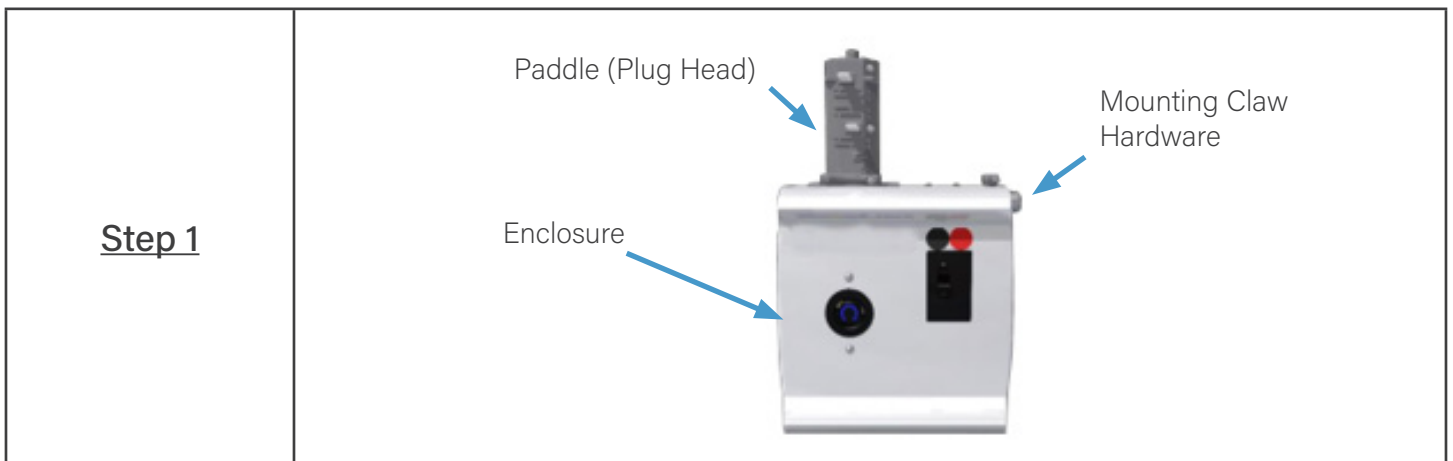

DO NOT install Plug-in units under load. Make sure breakers are in the off position

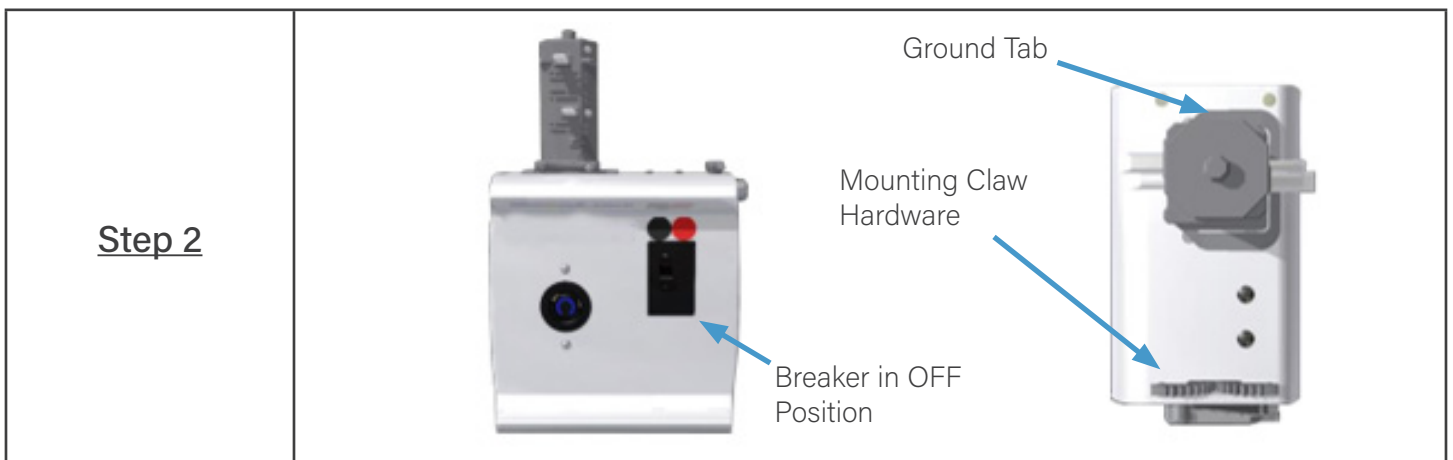



800T5 US SYSTEMS

PLUG-IN INSERTION INSTRUCTIONS

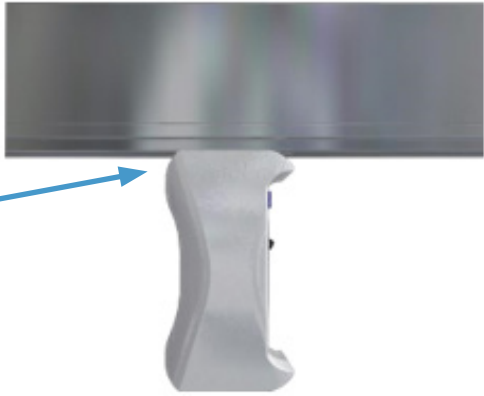
<p><u>Step 3</u></p>	<p>Guide the paddle into the access slot of the busway</p> 
-----------------------------	---

<p><u>Step 4</u></p>	<p>Plug head inserted <u>completely</u> into busway</p> 
-----------------------------	---

<p><u>Step 5</u></p>	<p>Rotate so that the blades engage the busbars</p> <p>Enclosure firmly pressed up against the busway.</p> <p>(Hint: push UP against the busway as you begin to rotate)</p> 
-----------------------------	--

<p><u>Step 6</u></p>	<p>Rotate plug-in to the right until it is parallel to the busway.</p> <p>The typical circuit breaker/receptacle faces the direction of the polarizing strip for the T5 systems.</p> 
-----------------------------	---

<p><u>Step 7</u></p>	<p>Engage lever to operate the mounting claw.</p> <p>If installing an older style plug, insert hanger bolt to mounting tab and securely tighten.</p> 
-----------------------------	--

<p><u>Step 8</u></p>	<p>Rotate locking lever to secure the locking claw</p> 
-----------------------------	---

REMOVING A PLUG-IN UNIT

<p>Step 1</p>	<p>Put breaker in OFF position</p>  <p>DO NOT remove under load</p>
----------------------	--

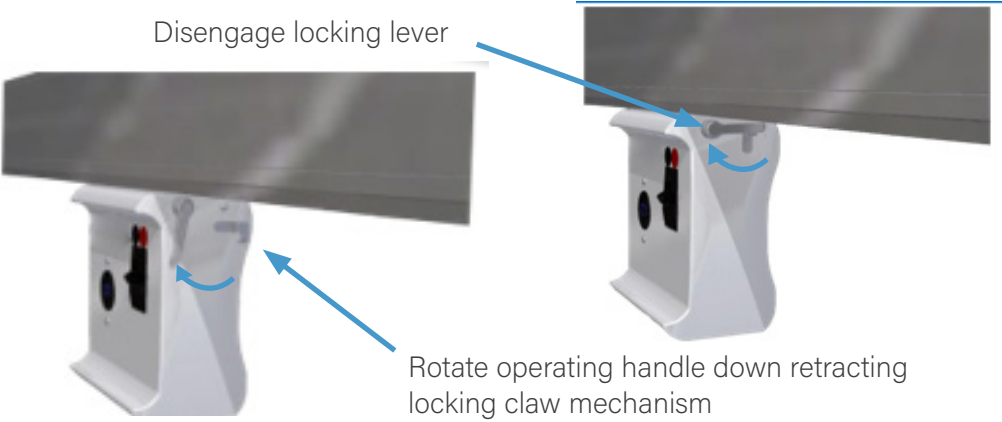
<p>Step 2</p>	<p>Disengage locking lever</p>  <p>Rotate operating handle down retracting locking claw mechanism</p>
----------------------	--

<p>Step 3</p>	<p>Rotate the enclosure 90 degrees and pull down until the paddle is clear of the busway</p> 
----------------------	---

PLUG-IN DISTANCE CLEARANCES

Side Distance Clearance

The following tech brief shows the side and height clearances of standard Starline enclosures.

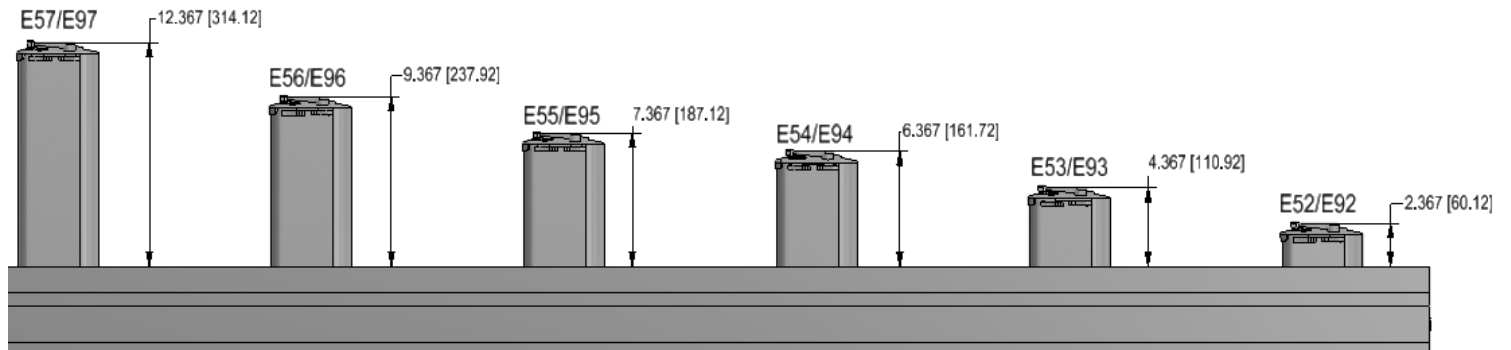
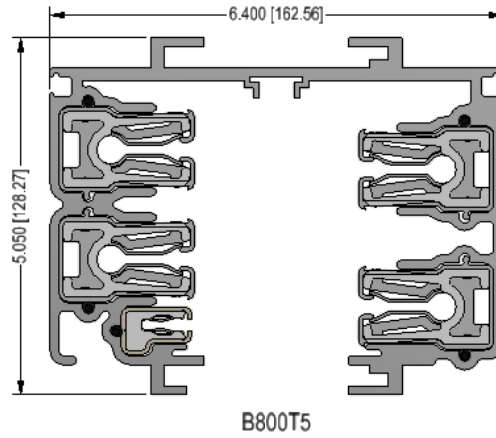

Enclosure E12

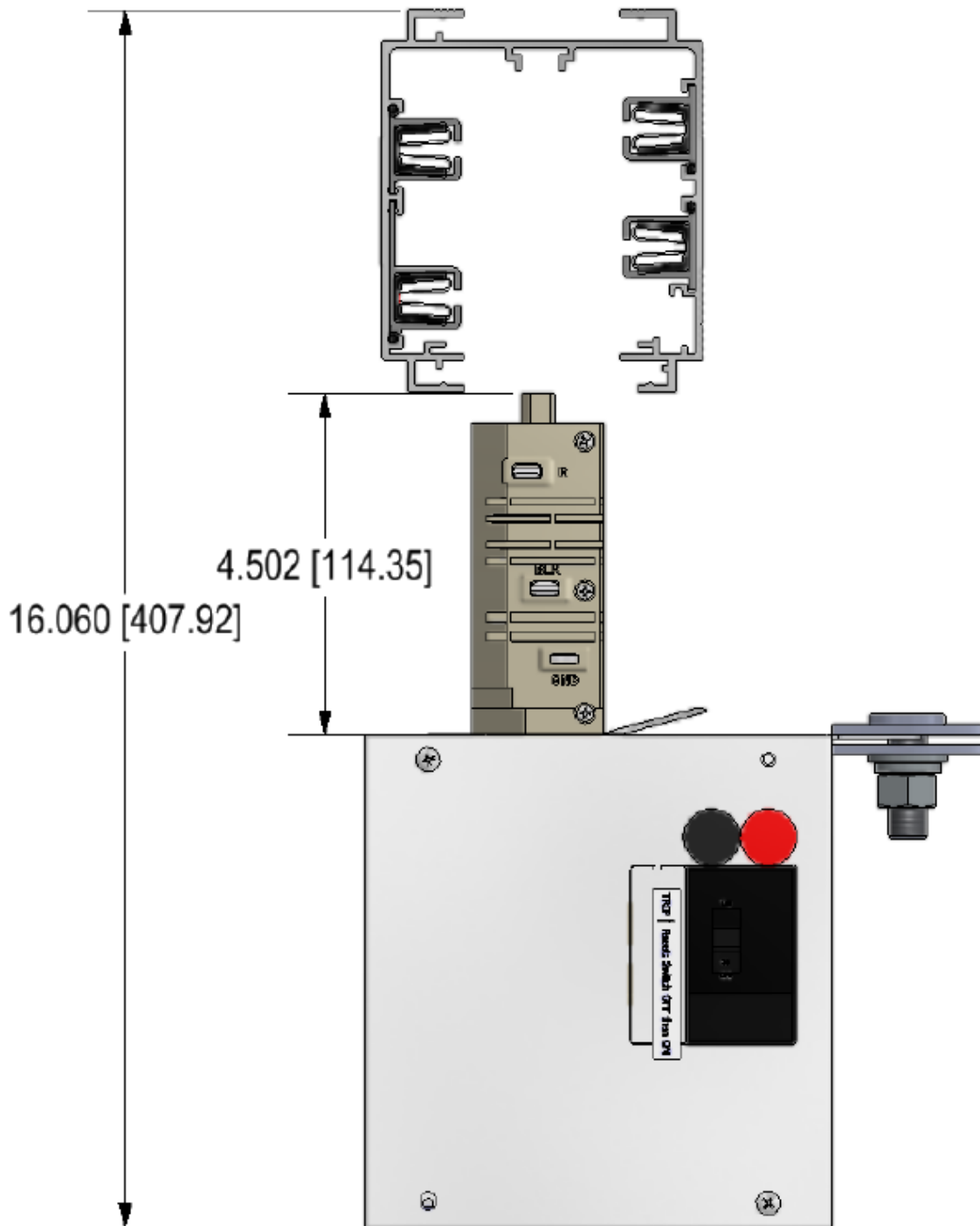

Enclosure E28

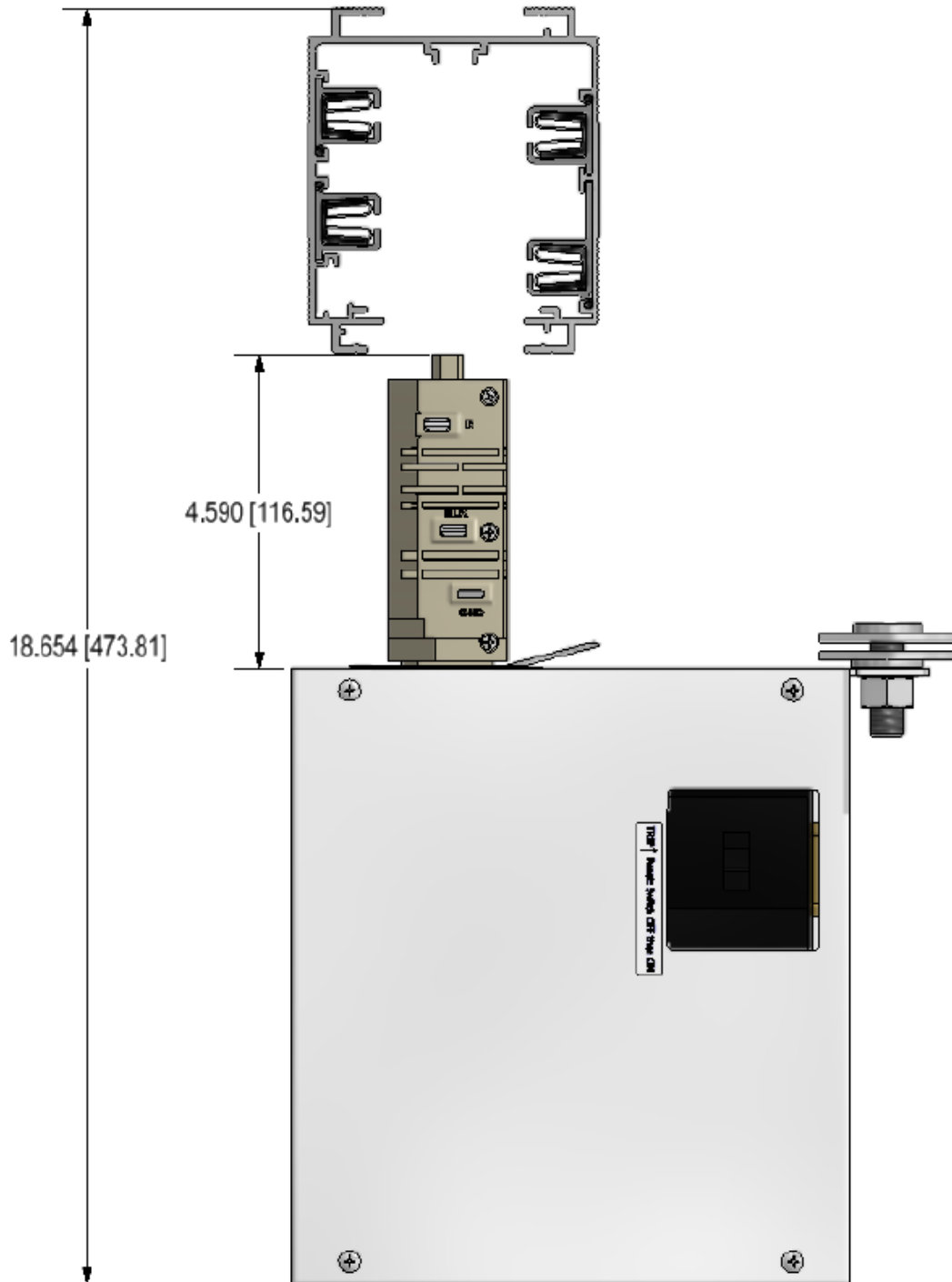

Enclosure E36

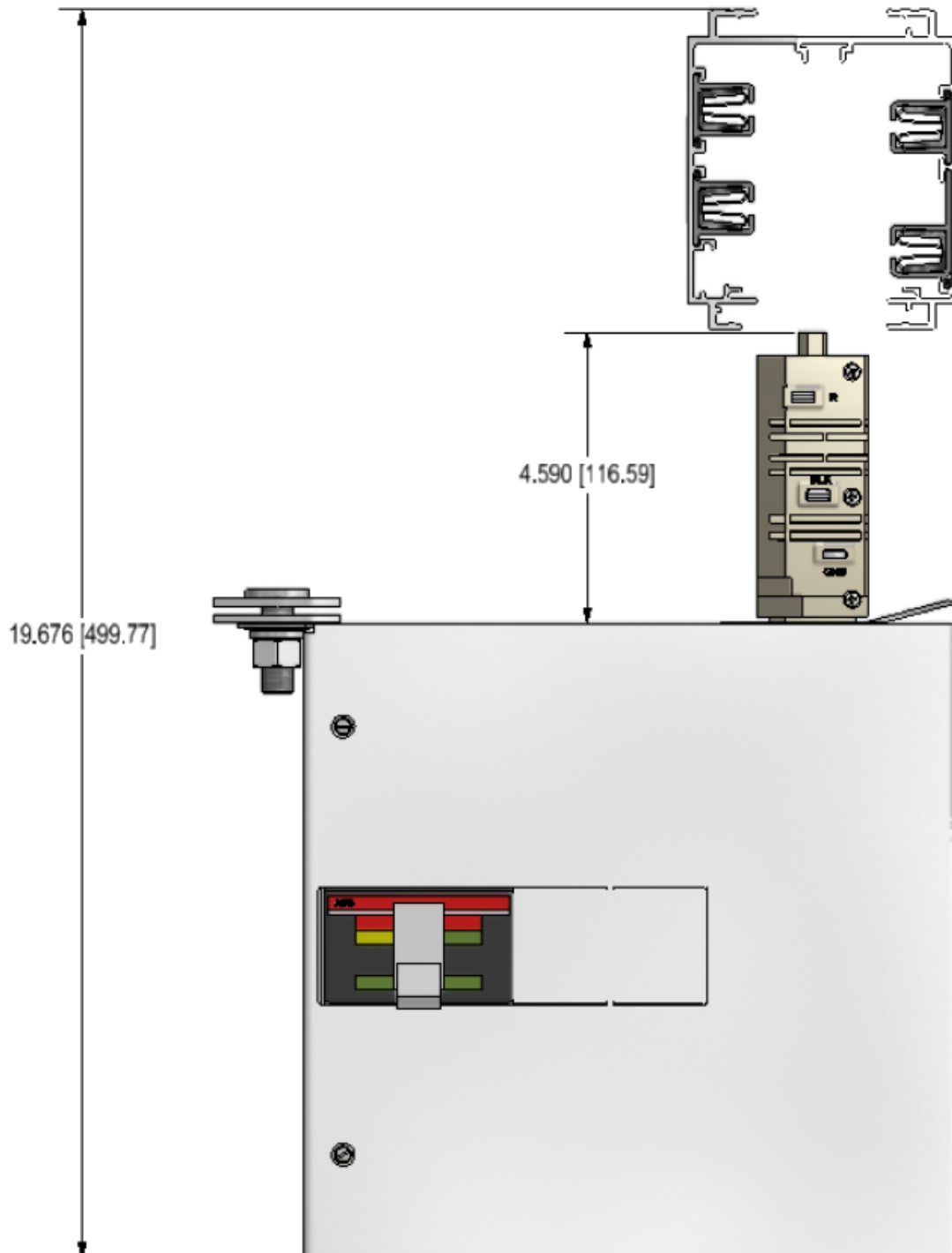

Enclosure E25

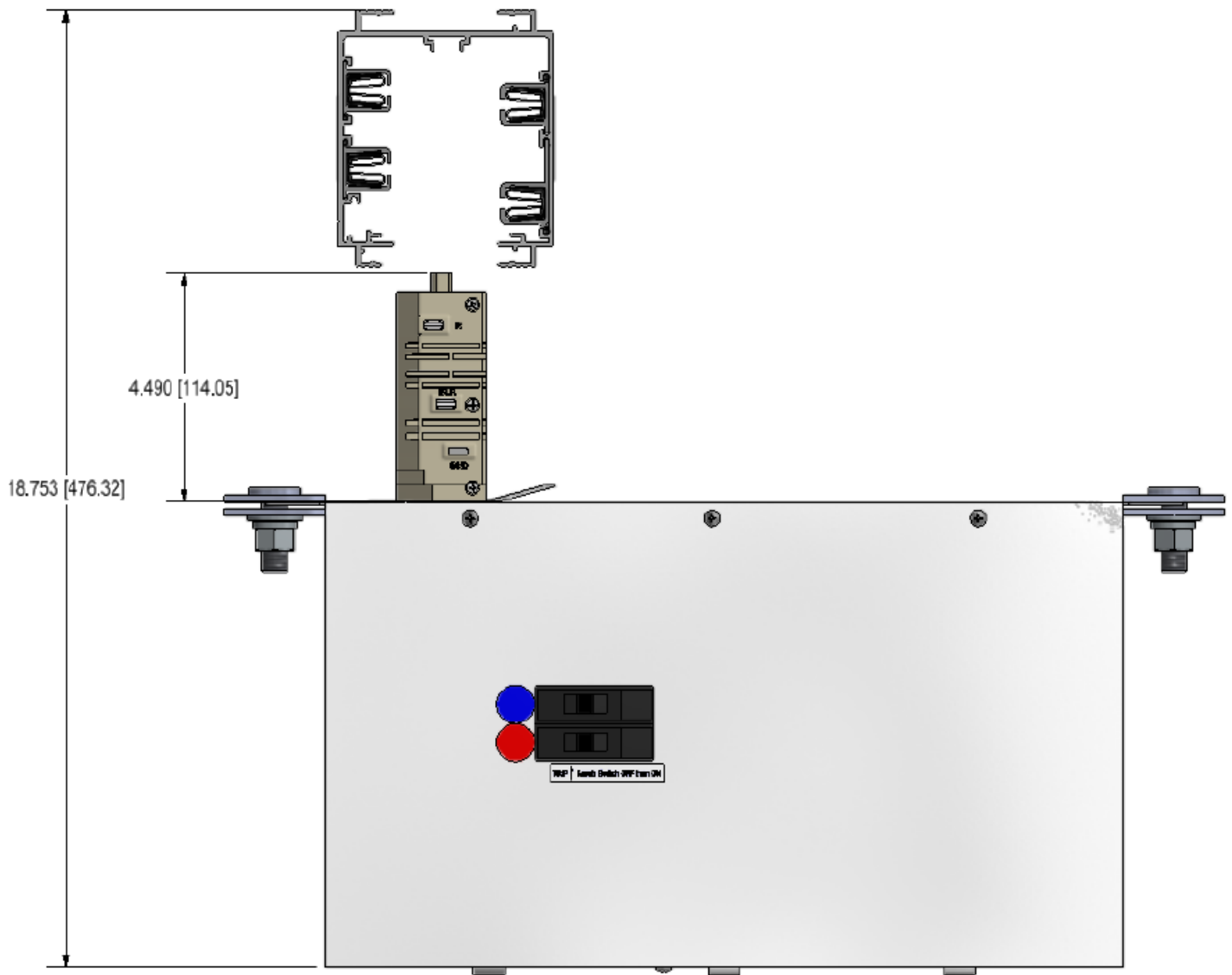

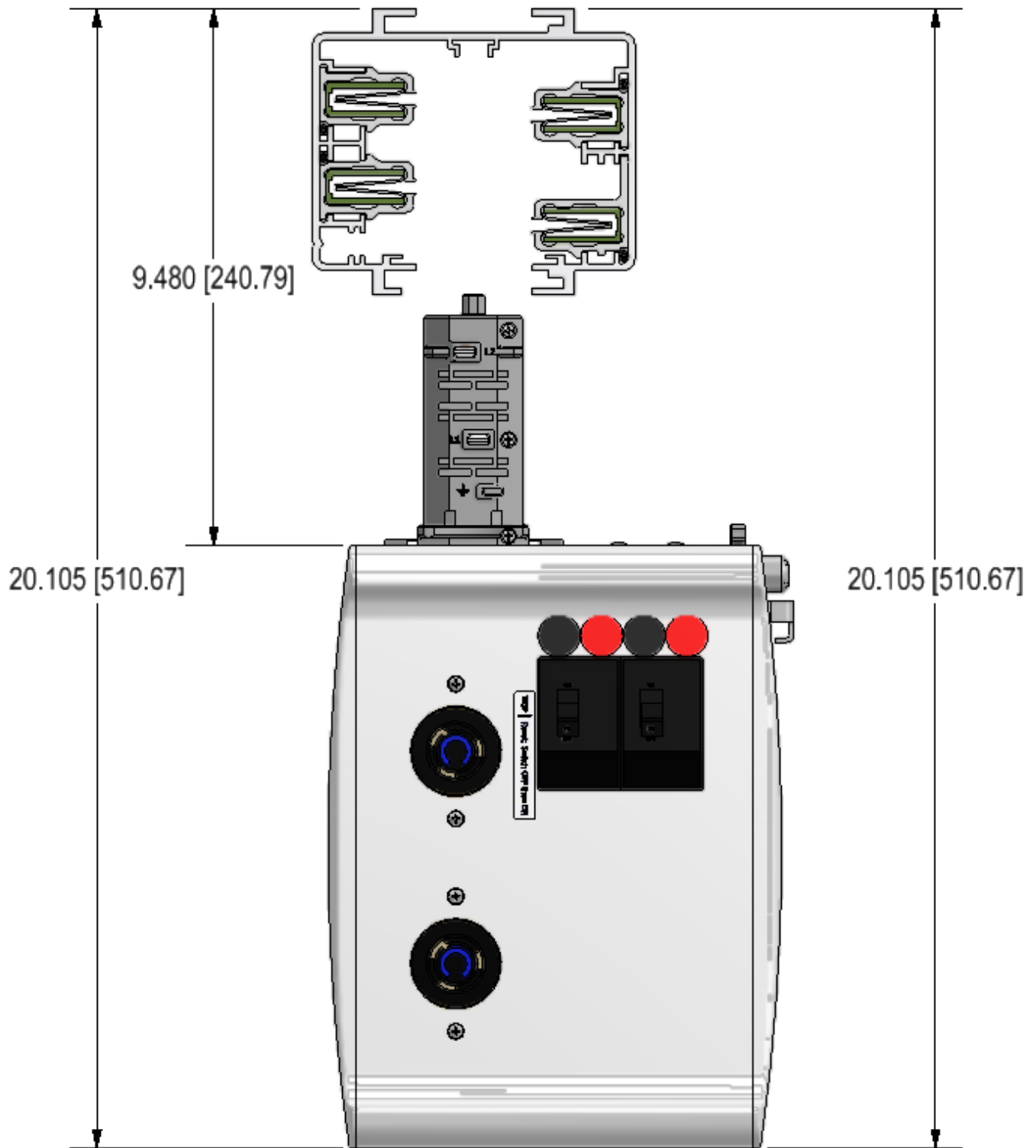

E50 Series Plug Shown

800T5 US SYSTEMS

PLUG-IN INSERTION INSTRUCTIONS

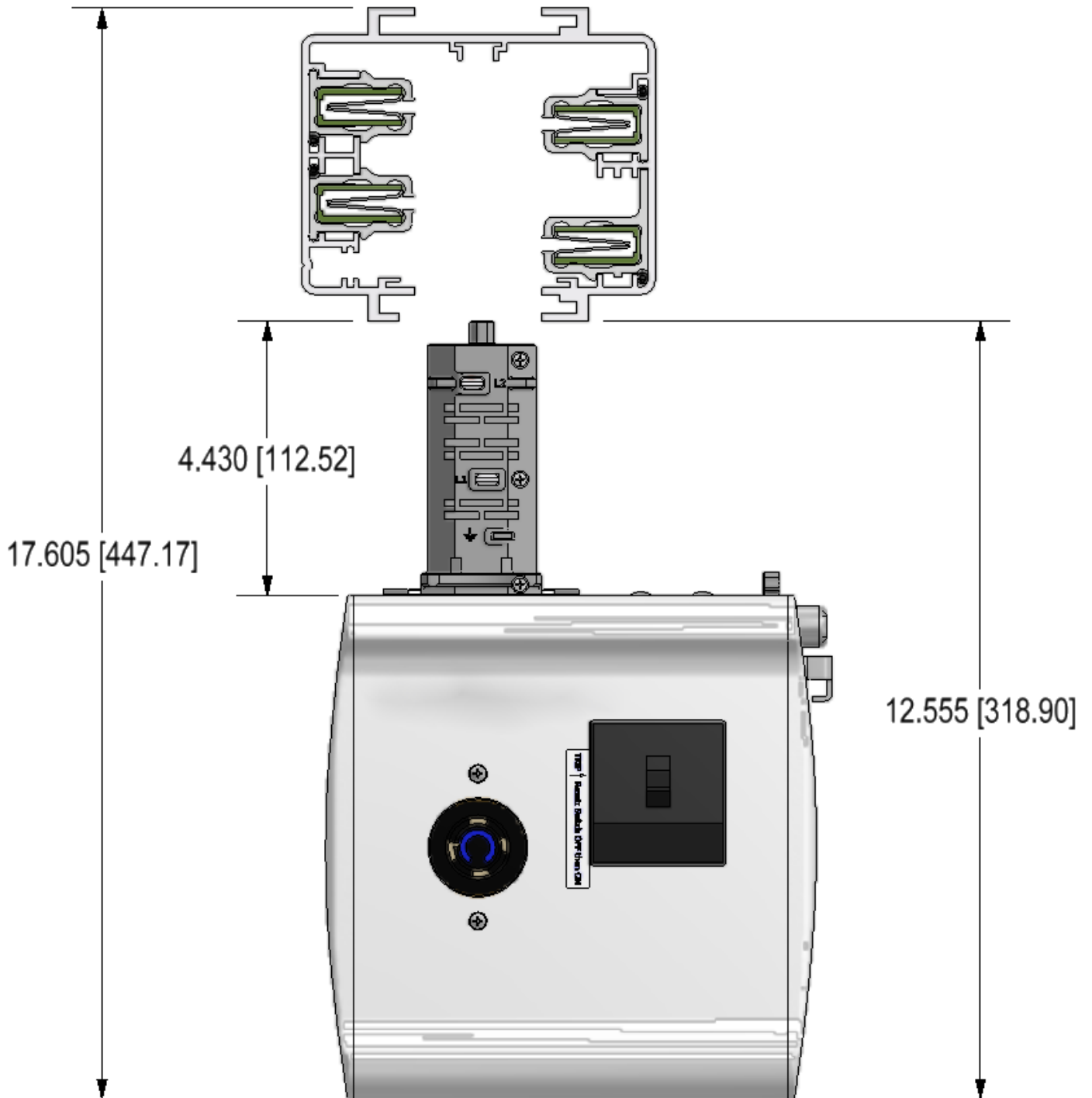

E90 Series Plug Shown

Section 4: Field Services and Warranty



STARLINE SERVICES

Regular servicing of busway systems is crucial for ensuring that your system performs at its best. By conducting regular maintenance, you can identify and address any potential issues before they turn into expensive problems, thus saving you time and money in the long run. Regular servicing can help extend the lifespan of your busway system, ensuring that it meets safety standards and complies with regulations. Choose from various offerings and customize a service plan that works best for you..

WE ARE CURRENTLY OFFERING THE FOLLOWING SERVICES:

COMMISSIONING AND EQUIPMENT RENTALS

Designing a mission-critical facility involves a significant investment of time and money. Through comprehensive commissioning services, Starline can help guarantee your project delivers the outcomes you expect.

Whether you need rental equipment to test your busway system or certified technicians to perform the testing, Starline has you covered. Choose from our inventory of load bank tap-offs and associated gear, or work with a Starline Engineer to customize and perform a commissioning plan to fit your specific needs.

METER SERVICES

Starline's certified technicians make optimizing your meters' performance and functionality a breeze. Our comprehensive on-site meter programming service includes inspecting, programming, reporting, and optional retrofitting services for you existing systems.

STARTUP AND SYSTEM CERTIFICATION

At Starline, we are committed to ensuring the success of your project. Our team understands the risks associated with the energization of systems, which is why we've designed a rigorous certification process to inspect, test and report on your Starline Busway and Critical Power Monitor ("CPM") products. Our certification process proactively identifies and prevents any potential issues before they happen.

To ensure the long-term success of your project, it is crucial to have Starline-certified technicians inspect and validate the installation before full commissioning. Level 2 and 3 commissioning ensures the installation complies with safety requirements and meets factory standards for ongoing reliability.

- Double the length of the standard factory warranty
- Ensure all joint and feed connections are properly installed with continuity testing
- Ensure proper installation of all plug-in units
- Validate that system will perform to your specified requirements
- Full certification report delivered electronically at conclusion of service

Contact your Starline Representative today to add services to your Track Busway order, or download the detailed Statement of Work documents at downloads.starlinepower.com/services

STARLINE SERVICES

TURNKEY INSTALLATION SERVICES

Our trained and factory certified Busbar installers are looking forward to completing your next job. You can order your best-in-class power distribution system and leave the rest to us. Our technicians will complete your installation quickly and safely and will reduce your overall TCO by extending your product warranty.

PREVENTATIVE MAINTENANCE PLANS AND IR SCANNING

Although Starline busway is expertly designed to require less maintenance, NETA ATS and MTS guidelines recommend conducting annual inspections and health assessments on all critical equipment. Yearly preventative maintenance helps to ensure your system's long-term reliability and safety.

Starline's FLIR-certified technicians will create a custom preventative maintenance plan for your specific needs. Our certified technicians will work to:

- Identify thermal anomalies
- Extend equipment lifecycle
- Ensure optimal system performance
- Improve facility safety and operational sustainability

Upon completing your preventative maintenance plan, you may be eligible to extend your product warranty.

ON-SITE INSTALLATION SUPPORT

Starline's on-site installation service makes installing your busway as quick and easy as possible.

Our installation support starts with scheduling a preliminary trip to the installation site. During the initial visit, our certified technicians will train your installing contractor and develop a thorough installation and commissioning plan.

After completing the training, your installing contractor will have a direct line of communication with our installation experts. Our experts can help answer questions and provide hands-on guidance when needed.

Opting for Starline's installation support helps mitigate the installation risk and reduces the learning curve typically associated with new installations.

Contact your Starline Representative today to add services to your Track Busway order, or download the detailed Statement of Work documents at downloads.starlinepower.com/services

STARLINE SERVICES

ON-SITE PRODUCT TRAINING

At Starline, we offer comprehensive on-site product training services facilitated by our team of certified technicians. With their extensive expertise and commitment to upholding our high factory standards, you can confidently rely on them to ensure your and your systems' reliability and operational safety.

Our training programs equip your team with the knowledge and skills necessary to operate and maintain your systems effectively. Through hands-on demonstrations and interactive sessions, our certified technicians will guide your staff in understanding the intricate workings of the products and address any questions or concerns your team may have during the training process.

By choosing our on-site product training services, you are investing in your system's and operations' longterm success.

RECERTIFICATION AND EXTENDED WARRANTY PLANS

Starline's recertification and extended warranty options provide best-in-class coverage for all of your Starline products and systems. Our extended warranty plans safeguard your investment beyond the standard warranty timeframe, offering you peace-of-mind while our recertification programs help mitigate risk and downtime. Whether the busway has been installed for years or you are relocating to another building, Starline is here to help.

Choose from one of our flexible one to four-year plans or have your system recertified anytime. Contact your Starline rep for more information.

Contact your Starline Representative today to add services to your Track Busway order, or download the detailed Statement of Work documents at downloads.starlinepower.com/services

STANDARD FACTORY WARRANTY

Contractor/Customer: _____

Customer Order: _____

Seller warrants all products sold by Starline Holdings, LLC to be free from defects in material or workmanship for a period of one year from the date of shipping. Seller's liability on this warranty shall be limited to the repair or replacement of any product which is returned to the Seller, within one year of the date of delivery and which is found by the Seller to be defective in material or workmanship. Customer must have written authorization prior to returning any material to Starline. The Buyer will be responsible for the cost of removing and reinstalling a defective part(s) or its replacement and all labor and material and all other costs or expenses incurred in connection therewith.

Notwithstanding any provision contained herein to the contrary, (i) Buyer's use of any plug-ins, parts and/or components that are not manufactured by Starline with the Products, and/or (ii) if any services and/or warranties are provided by any person/entity other than Starline without Starline's prior written consent, all warranties for all Products shall immediately terminate and be null and void.

Warranty Period: 1 year from delivery date

STANDARD FACTORY WARRANTY PROCESS

1. Customer calls either Starline Rep or Starline direct.
2. Customer Service Specialist will issue Return Material Authorization (RMA).
3. Customer returns warranted item along with copy of RMA.
4. Starline will either rework item or manufacture new item depending on the customer needs.
5. Starline ships item back to customer.
6. Starline will determine reason for failure.
7. Corrective action will be documented.
8. If reason for failure is requested by customer. Starline will send report to customer.
9. All action items from corrective action report must be completed by assigned designer and returned to Quality Department.
10. Quality Assurance Department will track all warranted events and report them to Starline Managers, Directors, and the Executive Team.

800T5 US SYSTEMS

FIELD SERVICES AND WARRANTY



Section 5: Maintenance

STARLINE BUSWAY RECOMMENDED MAINTENANCE

Starline Track Busway is designed to be user friendly with no mandatory maintenance required. The joints, end feeds, and plugs also require little to no maintenance. Starline Track Busway uses a boltless connection for the joining of the copper conductors. The joint design uses a U-shaped conductor channel that utilizes a joint kit to connect two housing sections. This connection is mechanically pressed into the slot with the use of installation tools that can be purchased from Starline. The end result is a reliable, heat tested connection at every joint that takes little to no maintenance over the life of the product.

The housing couplers, end feed connections, mounting hardware, and hanger bolts can be checked at the user's discretion, but is not required by Starline Holdings, LLC.

IR inspection of the end feed connections, joints, and plug-in units can be checked at the user's discretion, but is not required by Starline Holdings, LLC.

We do recommend that the system be inspected periodically for physical damage or signs of any abnormalities.

Starline conductor insulation systems are produced using performance polymer materials. Therefore, it should be noted that Starline strongly advises against the use of hydrocarbon based products found in commonly used release sprays & cleaning fluids, due to potential non-compatibility.

Starline offers comprehensive on-going service plans that extend the life of the warranty over the duration of the plan. For more information, contact your Starline sales representative or email the factory at service@starlinepower.com.

- Refer to NEMA bulletin BU1.1 for general maintenance instructions.

Starline, a brand of Legrand, has been a leader in power distribution since 1924. The company's founders led the way for many new technologies in the power distribution equipment industry. Today, Starline continues to pave the way for safer, more innovative and more reliable electrical power distribution systems. Visit StarlinePower.com to learn more about our flexible power solutions.

Starline[®]
A brand of **legrand**[®]

North American Headquarters
168 Georgetown Road | Canonsburg, PA 15317 | USA | +1 800-245-6378

UK & Northern Europe
Unit C Island Road | Reading RG2 0RP | UK | +44 (0) 1183-043180

Asia Pacific Region
16D Tuas Avenue 1 | #04-60/62 | JTC Space @ Tuas | Singapore 639536 | +65 6950-1247

StarlinePower.com

+1 724-597-7800 | +1 800-245-6378

5/24 F0900046

