

Reference(s) :

see relative catalogue for detailed reference tables

XCP - Xtra Compact high power busbar system



CONTENT

1. USE	1	5. ACCESSORIES	10	B) Cover plate and bar drillings	18
2. RANGE	1	10.1 Adapter element	10	B.1) XCP-S	18
2.1 Features	1	10.2 Brackets	10	B.2) XCP-HP	20
2.2 Composition	2	10.3 End cover	12	C) Technical data	22
3. TECHNICAL INFORMATION	7	10.4 Protective bellow	12	C.1) XCP-S ALUMINIUM	22
3.1 General features	7	10.5 Flexible connections	12	C.2) XCP-S COPPER	26
3.2 Weights	8	10.6 ATR elements	13	C.1) XCP-HP ALUMINIUM	30
3.2 Temperature deratings	9	10.7 Tap-off boxes	13	C.2) XCP-HP COPPER	34
4. CONFORMITY	9	6. APPENDIX	17		
4.1 Marking	10	A) Table dimension vs ratings	17		

1. USE

XCP is the new Starline busbar trunking system ranging from 630A to 6300A with a degree of protection up to IP55*.

It is the most suitable solution for the transport and distribution of energy in data center, industrial, and commercial installations.

Typical applications are data centers, industry, riser end feed units, commercial and service sector buildings (banks, hospital, business centers).

While maintaining the same basic characteristics, such as the range of rated current, the construction materials and the number of accessories available, XCP-S and XCP-HP have different properties that make them able to satisfy all the demands of the world market.

XCP-S is the optimised solution for the most common performance requirements (lighter and smaller because of a reduced sections of internal conductors), making it the right choice for standard applications.

XCP-HP is the busbar system characterized by higher performances on energy saving and higher short circuit withstand. It is designed to work at 55° C of ambient temperature: ideal for heavy duty applications, higher temperature environments and installations where high energy efficiency is required.

* The standard degree of protection is IP55. IP65 is available by request (only for transport of energy).

2. RANGE

2.1 Features

XCP is available with aluminium or copper conductors and it is characterized by a smart and ultra-compact design.

The external dimensions don't change based on the number of conductors. The length and height change with the rating but are the same for all three combinations of conductors (3 - 4 - 5 conductors) available.

Often, for the transport and the distribution of high power (5000A Al /6300A Cu rated current), the energy distribution consists of a parallel of two independent busbars.

With XCP multi-bar design is always supplied in a single structure ensuring simpler installation compared to independent run designs.

XCP is available in:

- aluminium conductors (630 - 5000 A)
- copper conductors (800 - 6300 A)

In the following table, are shown the number of internal bars of XCP-S and XCP-HP (Single Bar, Double Bar or Triple Bar configuration):

Raating [A]	XCP-S		XCP-HP	
	ALUMINIUM	COPPER	ALUMINIUM	COPPER
630		-		-
800	S	S	S	S
1000				
1250				
1600				
2000				
2500	D	D	D	D
3200				
4000				
5000	T	T	T	T
6300	-	T	-	T

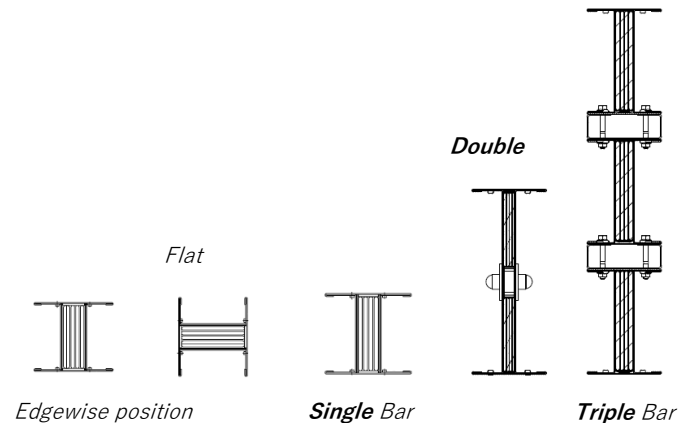

XCP - Xtra Compact high power busbar system

Reference(s) :

see relative catalogue for detailed reference tables

On request, also it is possible to have XCP line in non-standard versions. In the table below, some example of special version available:

Reference	Version description
64280102P	Standard 4 conductors (3Ph + N + PE casing)
64280102P-R5	4 conductors RAL painted on request
64240102P	5 conductors (3Ph + N + FE + PE casing)
64250102P	double neutral
64280102P-3W	3 conductors (3Ph + PE casing)
64280102PF	class F insulation (155 °C)
64280102P-RL	PEN conductor
64280102P-R3	with aluminum extra-ground (reinforced PE 3)
64280102P-R4	with copper extra-ground (reinforced PE 2)

Conductor versions:

- 3 conductors + PE: for applications where neutral distribution is not required
- 4 conductors + PE: with pariphase neutral
- 4 conductors + PE: with double neutral with respect to the phase section for applications with high values of third order harmonics (THD%)
- 5 conductors + PE: 3 phases + Neutral pariphase + FE functional earth + PE

Versions of PE:

- PE1 with casing used as earth conductor
- PE2: with additional earth in copper plate
- PE3: with additional earth in aluminium plate

For more details on special versions, please contact Starline.

2.2 Composition

XCP includes all the necessary components to enable any path for the busbar run that the project requires. The busbar system is composed of:

2.2.1 STRAIGHT ELEMENTS (for detailed references, see catalogue)

Designed for transport and distribution (with tap off outlets) of high-power energy. Supplied with its pre-installed monobloc.

Characteristic	Description
Reference standard	IEC 61439-6
Reference temperature	35 °C (XCP-S), 55 °C (XCP-HP)
Protection degree	IP55
Thickness of metal sheet	1.5 mm
N° of conductors	3, 4, or 5
Painted	RAL 7035
Halogen	free
Lenght A min/max [mm]	500/3000*

* Standard length is 3000 mm

STRAIGHT ELEMENTS for transport

The insulation between bars is ensured by a double sheet made with polyester film class B(130° C), class F (155° C) thermal resistance available on request.

All plastic components have a V1 self-extinguishing degree (as per UL94); they are fire retardant and comply with the glow-wire test according to standards.

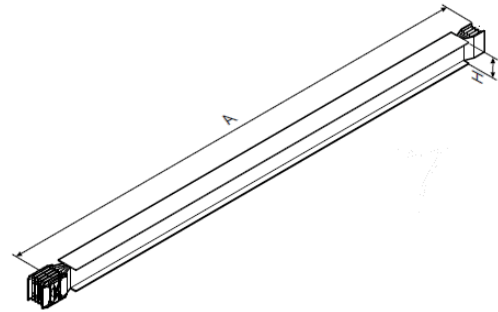

Dimension H changes with the ratings and it is specified in Table A (busbar dimension vs ratings), in appendix of the technical sheet

STRAIGHT ELEMENTS (for distribution)

Supplied with its pre-installed monobloc.

- Straight elements for plug-in type tap-off boxes
- Standard 3000 mm
- Tap-off outlets on both sides

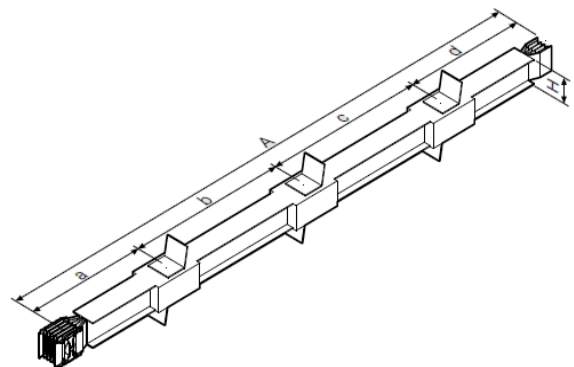

Dimension H changes with the ratings and it is specified in Table A (busbar dimension vs ratings), in appendix of the technical sheet

These straight elements enable the application of plug-in boxes on dedicated outlets. Available in lengths from 1 to 3 meters, these elements have respectively 1, 2 and 3 outlets at pre-set distances with center distances of 850 mm on both sides

XCP - Xtra Compact high power busbar system

Reference(s) :

see relative catalogue for detailed reference tables

Number of outlets vs length A:

Lenght A [mm]	Outlet numbers
3000	3+3 (**)
1001-1500	1+1
1501-2000	2+2 (**)
2001-2500	2+2 (**)
2501-2999	3+3 (**)

P.S: 630-800 A elements with aluminium conductors (Al) and 800-1000 A elements with copper conductors (Cu), where distributions are only available on the top side (in standard execution) for example "3+0"

On request, the length of the elements and the number and position of distribution outlets may be different from the standards measures.

These straight elements are designed for plug-in type tap-off boxes. The tap-off outlets are on both sides.

- length from 1001 mm to 1250 mm can only be installed with type1 and type 3 plug-in boxes
- From 1250 mm to 3000 mm is possible to install all types of plug-in boxes.

It is possible to have other combinations of outlets:

length: 1501 ÷ 2000 - outlets: (1+1)

length: 2001 ÷ 2500 - outlets: (1+1)

length: 2501 ÷ 2999 - outlets: (1+1) and (2+2)

length: 3000 - outlets: (1+1) and (2+2)

Possibility to have outlets in special position

For a correct evaluation of the number of outlets, take into account the length of the element and the size of the boxes to be installed.

2.2.2 SPECIAL ELEMENTS (for detailed references, see catalogue)

Designed to meet any installation requirement.

Fire barrier elements S120 EI120 (EN 1366-3)

When the busbar trunking system crosses fire resistant walls or ceilings, it must be fitted with appropriate fire barriers.

The fire barrier is 630 mm (Al) and 1000 mm (Cu) long and must always be positioned in the middle of the fire-resistant wall or ceiling crossed by the busbar.

After crossing fire resistant walls or ceilings, any cavity must be sealed with material meeting current regulations for the required building fire resistance class.

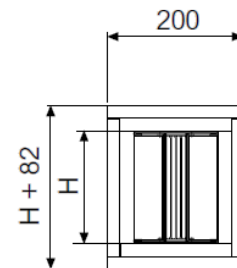
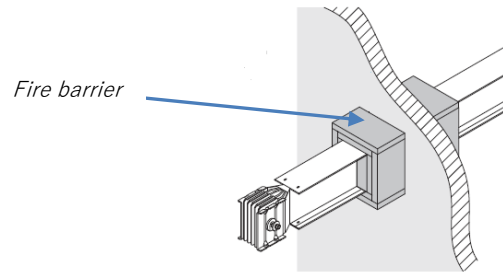

Dimension H changes with the ratings and it is specified in Table A (busbar dimension vs ratings), in appendix of the technical sheet

For some ratings it is necessary to have an internal fire barrier fitted at the factory following the guidelines on the tables:

USE OF INTERNAL OR EXTERNAL BARRIER (XCP-S)					
Al			Cu		
In (A)	Internal	External	In (A)	Internal	External
630 - 800	√	√	800 - 1000	√	√
1000 - 2000	-	√	1250 - 2000	√	√
2500 - 4000	√	√	2500 - 5000	√	√

USE OF INTERNAL OR EXTERNAL BARRIER (XCP-HP)					
Al			Cu		
In (A)	Internal	External	In (A)	Internal	External
630 - 800	-	√	800	√	√
1000	√	√	1000 - 2500	-	√
1250	-	√	3200 - 5000	√	√

It is therefore necessary to indicate at the order stage which elements will cross fire resistant walls or ceilings (see reference details on catalogue).

The external fire barrier can be used on any trunking component in compliance with the operating instructions (minimum dimensions) specified as follow:

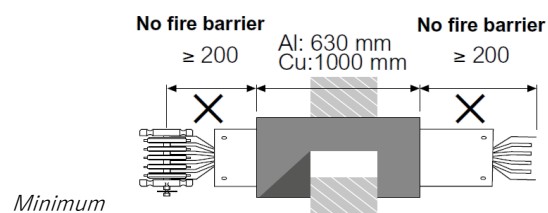

XCP - Xtra Compact high power busbar system

Reference(s) :

see relative catalogue for detailed reference tables

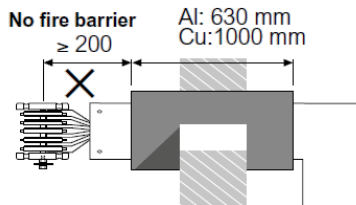

Minimum dimensions in an elbow element

To be comply to the Certification of Fire resistance it's necessary to install both internal (internal barrier in few ratings is not required) and external fire barrier supplied by Starline.

Expansion element

Due to being subjected to temperature changes, both the busbar and the building suffer thermal expansions. The expansion element can absorb expansion and contraction of both the busbar trunking system section and the building, up to the maximum permitted length (± 50 mm approx.).

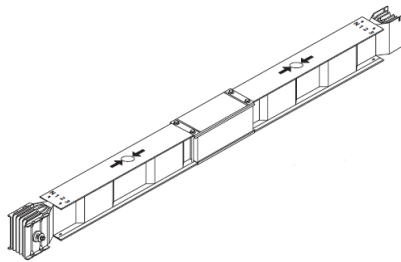

The length is 1.5 m and Dimension H changes with the ratings, and it is specified in Table A (busbar dimension vs ratings), in appendix of the technical sheet

The expansion element must be fitted near the expansion joints of the building and in straight sections of the line (horizontal and/or vertical) longer than 40 m.

For straight line sections longer than 40 m, expansion elements must be fitted in a way that splits the path into equal sections not longer than 40 m.

XCP-S busbar trunking system elements are designed to compensate for thermal expansion if the straight sections of the installation are less than 40 m; in this case no expansion element is necessary.

Here some example of installation distances:

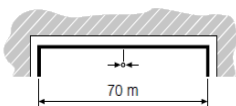

Straight section length 70 m:
n°1 expansion element in the center of the line

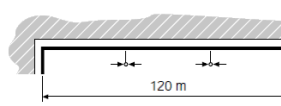

Straight section length 120 m:
n°2 expansion elements, one every 40 m

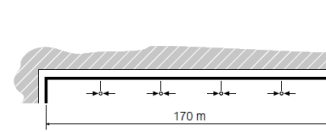

Straight section length 170 m:
no. 4 expansion elements, one every 34 m

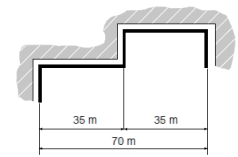

Section length 70 m. When the section is not straight, no expansion element is necessary

Phase balancing element

Straight elements with phase balancing are used to reduce and balance mutual phase reactance and impedance in case of long lines.

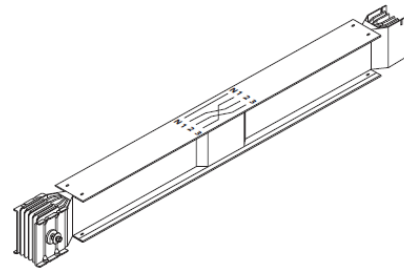

The length is 1.2 m and dimension H changes with the ratings, and it is specified in Table A (busbar dimension vs ratings), in appendix of the technical sheet

In long sections (> 100 metres) it is recommended that two transposition elements are fitted (one at one third and one at two thirds of the path), to balance the system electric impedance:

In this way, it will be possible to have along the installation path all the possible combination, of reciprocal positions among phases, minimising load losses:

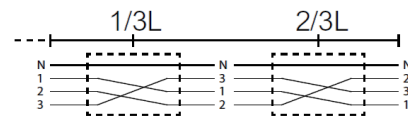

If it's necessary to have the same phase sequence at the start and the end, use 3 phase balancing elements:

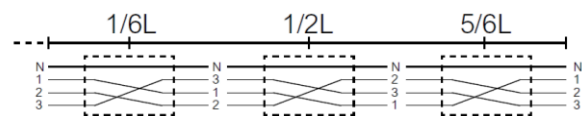

If it's necessary to have the same phase sequence at the start and the end, use 3 phase balancing elements

XCP - Xtra Compact high power busbar system

Reference(s) :

see relative catalogue for detailed reference tables

Phase inversion element (*)

The function of this element is to completely reverse the positions of the phases and the neutral. It is normally used in the connections between the transformer and the electric board, or in the connection between electric boards, when the starting sequence is different to the arrival sequence.

The length is 1.2 m and dimension H changes with the ratings, and it is specified in Table A (busbar dimension vs ratings), in appendix of the technical sheet



Neutral rotation element (*)

The straight element with neutral rotation is used to adapt the sequence of the busbar phases to the sequence of the connections required at the ends of the connections, should these be different.

In the connection between electric boards, the neutral jump is normally used, as only the neutral position is normally identified. For example, when the position of neutral of the distribution board phases is different from that of the transformer, it is possible to use an element that allows a neutral rotation only.

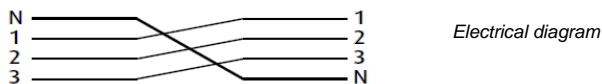

(*) Use phase inversion and neutral rotation elements ONLY for transport paths, and not for derivations (for any doubts please contact Starline)

2.2.3 FEED UNIT

The feed units are used at the end of the lines, when the busbar must be powered using cables.

They are available in 2 versions with or without monobloc. On request, they are available also for non-standard versions.

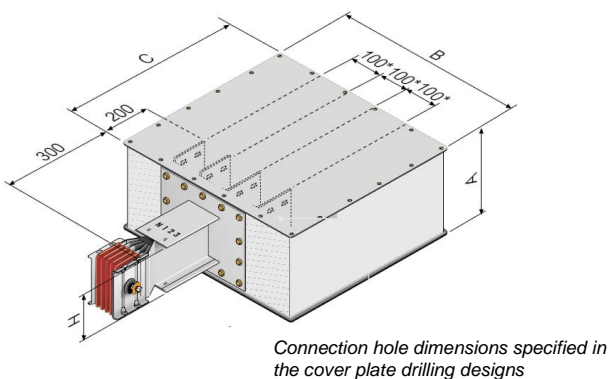

Dimension H changes with the ratings and it is specified in Table A (busbar dimension vs ratings), in appendix of the technical sheet

The rising mains feed units are used at the departure of the riser mains lines, when the busbar must be placed close to the wall and powered using cables.

They are available in 2 versions with or without monobloc, and they allow the busbar to be installed 40 mm away from the wall.

On request, they are available also for non-standard versions.

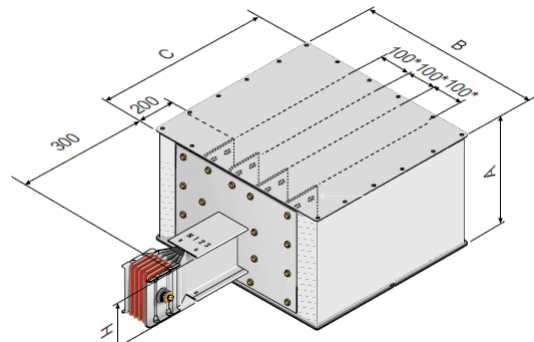

Connection hole dimensions specified in the cover plate drilling designs below

* 120 mm for 6300 A (Cu) and 5000 A (Al)

Dimension H changes with the ratings and it is specified in Table A (busbar dimension vs ratings), in appendix of the technical sheet

For more installation details, see relative guide.

Here below, the dimension table valid for both feed units and rising main feed units:

FEED UNIT DIMENSIONS				
Aluminium	630A÷1250A	1600÷2000A	2500A÷4000A	6300A
Copper	800A÷1250A	1600A÷2000A	2500÷5000A	
(A) [mm]	320	320	600	815
(B) [mm]	615	615	615	615
(C) [mm]	610	810	810	810

Special dimensions (not standard) are available on request, please contact Starline

See schemes on cover plate and bar drilling details in section B, in appendix of the technical sheet

XCP - Xtra Compact high power busbar system

Reference(s) :

see relative catalogue for detailed reference tables

2.2.4 ELBOW ELEMENTS

Supplied with its pre-installed monobloc, these elements are able to meet any change of direction with standard or special solutions.

These are the possible types:

- Horizontal
- Vertical
- Double (horizontal and vertical)
- Double horizontal + vertical
- Double vertical + horizontal
- T elbow (horizontal and vertical)

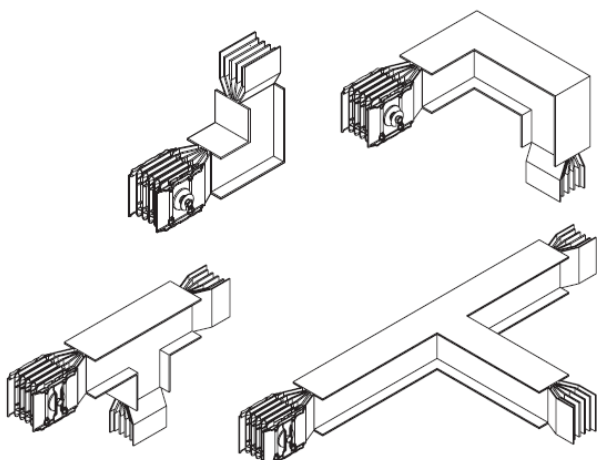

characteristics, dimension and items), see catalogue and project tool PSZ.

2.2.5 CONNECTION INTERFACE

Standard connection interfaces are used at the end of the lines to connect the busbar to boards or transformers. They are available in right (without Monobloc) and left (with Monobloc fitted) versions. The drawings below refer to the standard versions.

Different non-standard solutions are available on request (e.g.: length, center distance between bar conductors, drilling, etc.)

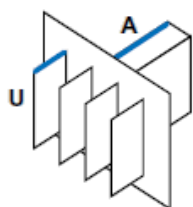

Interface Right
(Type 2 without monobloc fitted)

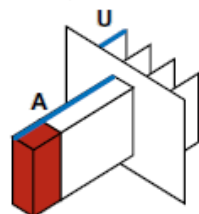

Interface Left
(Type 1 with monobloc fitted)

Interface with exit bars for panel boards

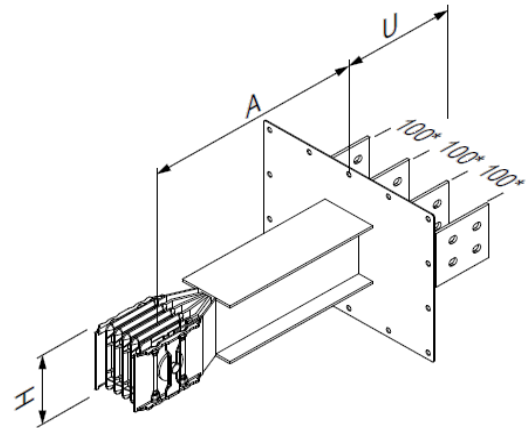

* 120 mm for 6300 A (Cu) and 5000 A (Al)

Dimension H changes with the ratings and it is specified in Table A (busbar dimension vs ratings), in appendix of the technical sheet

In table below, the dimension for all type of bars associated:

min. / MAX. DIMENSION [mm]	
Single bar	
U	150/400
A	200/1299
Double bar	
U	150/400
A	200/1299
Triple bar	
U	150/400
A	200/1299

The dimensions are referred to the standard elements. Single/double/triple bar (U+A): 200+300 mm

No standard elements "special" (with measurements that are different

from those show in the table above) are referred to the minimum and maximum dimensions specified in the table.

* For drawings with all drilling details for dimensions of cover plate and bars, see dedicated section at the end of this document.

XCP - Xtra Compact high power busbar system

Reference(s) :

see relative catalogue for detailed reference tables

Interface with exit bars for transformers

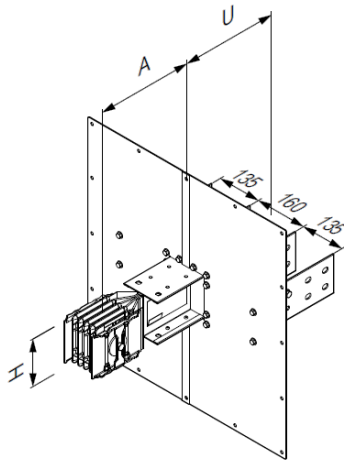

Dimension H changes with the ratings and it is specified in Table A (busbar dimension vs ratings), in appendix of the technical sheet

In table below, the dimension for all type of bars associated:

min. / MAX. DIMENSION [mm]	
Single bar	
U	300/400
A	200/1299
Double bar	
U	300/400
A	200/1299
Triple bar	
U	300/400
A	200/1299

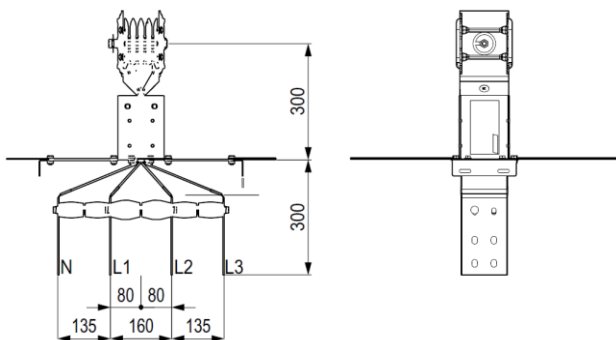

Flange size details

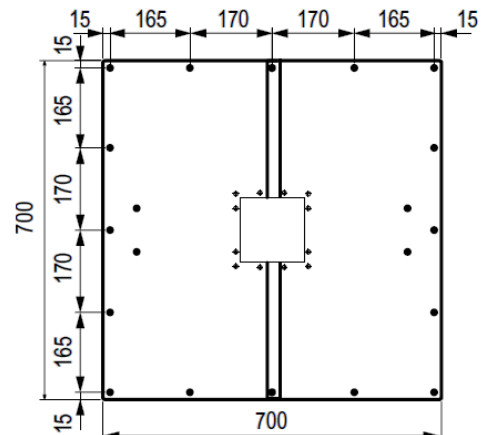

3. TECHNICAL INFORMATION

3.1 General features

XCP line is available in the standard range:

- from 630A to 5000A with aluminium alloy conductors
- from 800A to 6300A with copper conductors.

The super-compact dimensions of the XCP enhance its resistance to short circuit stresses; in addition, they can reduce the impedance of the circuit by controlling the voltage drops and allow for the installation of high power electrical systems, even in extremely confined spaces.

XCP is available with a wide selection of tap-off boxes that range from 63A up to 1250A, thus allowing you to locally protect and feed different types of loads by housing protective devices such as fuses, MCCBs and motorised switches XCP-S is not only in compliance with the harmonised standard IEC EN 61439-6 but also answers specifically to many clients' needs for more severe conditions of use. Thus, the rated current of Starline's busbar trunking systems is always referred to the average ambient temperature of 35 ° C for XCP-S and up to 55 ° C for XCP-HP.

The nominal range of all XCP is guaranteed both for horizontal installations (flat and edgewise) and for vertical installations without derating.

XCP busbar trunking systems are designed so that they can be maintenance-free, except for the periodic and compulsory inspections required by IEC 60364.

The tightening torque inspection of the junction can be carried out by qualified personnel, even when the busbar is energised.

The outer casing of the XCP line consists of four C-ribbed section bars, bordered and riveted (thickness 1.5mm), with excellent mechanical, electric and heat loss efficiency.

XCP - Xtra Compact high power busbar system

Reference(s) :

see relative catalogue for detailed reference tables

The sheet metal is made of galvanized steel, treated according to UNI EN10327 and painted with RAL7035 resins with a high resistance to chemical agents

The standard degree of protection is IP55, on request IP65 (only for transport of energy); with certain accessories, it can also be installed outdoors.

The busbar conductors have a rectangular cross section with rounded corners; there are two versions:

- electrolytic copper ETP 99.9 UNI EN13601
- aluminium alloy treated over the entire surface with 5 galvanic processes (copper plating + tin plating)

The insulation between bars is ensured by a double sheath made with polyester film (total thickness 2x0.19 mm) class B (130° C), (total thickness 2x0.23 mm) class F (155° C) thermal resistance available on request. All plastic components have a V1 self-extinguishing degree; they are fire retardant and comply with the glow-wire test according to standards

XCP line is Halogen Free. In order to facilitate storage operations especially to reduce the installation time, the straight elements, trunking components as well as all the components of the XCP line are supplied with a monobloc pre-installed at the factory

The junction contact is ensured by tin plated aluminium for XCP Al and copper for XCP Cu for each phase, insulated with red class F thermosetting plastic material.

The monobloc has shearhead bolts: after tightening the nuts with a standard wrench, the outer head will break at the correct torque value, hence giving you the certainty that the connection has been made properly so as to guarantee safety and maximum performance over time

Finally, in order to completely verify the insulation level, every finished

product undergoes an insulation test (phase-phase, phase-PE) at the factory with a test voltage of 3500 Vac for 1.5 seconds. The test is performed on the finished product, completely assembled.

IP55 and IP65 is intended for internal use only, for outdoor applications

is needed a canopy designed by us or RCP resin IP68 busbar.

3.2 Weights

In the following tables, the specific weights for each line and material are shown.

3.2.1 XCP-S Aluminium

Weight [kg/m]	Type	XCP-S 3C Al			XCP-S 4C Al			XCP-S 5C Al			XCP-S 2N Al		
	PE version	(PE 1)	(PE 2)	(PE 3)	(PE 1)	(PE 2)	(PE 3)	(PE 1)	(PE 2)	(PE 3)	(PE 1)	(PE 2)	(PE 3)
SINGLE BAR	I _n [A] 630	13.3	16.6	14.3	14.3	17.6	15.4	15.3	18.6	16.4	15.3	18.6	16.4
	I _n [A] 800	14.2	17.5	15.3	15.6	18.9	16.7	17.0	20.3	18.0	17.0	20.3	18.0
	I _n [A] 1000	14.5	17.8	15.5	16.0	19.3	17.1	17.6	20.9	18.7	17.6	20.9	18.7
	I _n [A] 1250	16.6	21.0	18.0	18.6	22.9	20.0	20.5	24.9	22.0	20.5	24.9	22.0
	I _n [A] 1600	19.8	24.6	21.4	22.5	27.3	24.1	25.2	30.0	26.7	25.2	30.0	26.7
DOUBLE BAR	I _n [A] 2000	23.6	30.1	25.5	27.4	33.9	29.2	31.1	37.6	33.0	31.1	37.6	33.0
	I _n [A] 2500	29.9	37.9	32.5	34.1	42.1	36.7	38.3	46.3	40.9	38.3	46.3	40.9
	I _n [A] 3200	35.9	45.4	39.0	41.5	51.0	44.6	47.1	56.6	50.2	47.1	56.6	50.2
TRIPLE BAR	I _n [A] 4000	42.9	53.4	46.4	50.4	61.0	54.0	58.0	68.6	61.5	58.0	68.6	61.5
	I _n [A] 5000	78.4	91.5	82.7	88.3	101.4	92.6	98.2	111.3	102.5	98.2	111.3	102.5

3.2.2 XCP-S Copper

Weight [kg/m]	Type	XCP-S 3C Cu			XCP-S 4C Cu			XCP-S 5C Cu			XCP-S 2N Cu		
	PE version	(PE 1)	(PE 2)	(PE 3)	(PE 1)	(PE 2)	(PE 3)	(PE 1)	(PE 2)	(PE 3)	(PE 1)	(PE 2)	(PE 3)
SINGLE BAR	I _n [A] 800	21.2	24.5	22.3	18.7	22.0	19.7	23.7	27.1	24.8	23.7	27.1	24.8
	I _n [A] 1000	23.8	27.1	24.9	20.6	23.9	21.7	27.1	30.4	28.1	27.1	30.4	28.1
	I _n [A] 1250	26.9	30.2	28.0	22.9	26.2	23.9	31.0	34.4	32.1	31.0	34.4	32.1
	I _n [A] 1600	33.5	37.8	34.9	28.0	32.4	29.5	38.9	43.3	40.3	38.9	43.3	40.3
	I _n [A] 2000	42.5	47.6	44.2	35.0	40.2	36.7	49.9	55.1	51.6	49.9	55.1	51.6
DOUBLE BAR	I _n [A] 2500	51.0	57.7	53.2	42.2	48.8	44.4	59.9	66.5	62.0	59.9	66.5	62.0
	I _n [A] 3200	63.0	71.0	65.6	51.9	59.9	54.5	74.1	82.1	76.7	74.1	82.1	76.7
	I _n [A] 4000	80.9	90.4	84.0	65.8	75.3	68.9	96.0	105.5	99.1	96.0	105.5	99.1
TRIPLE BAR	I _n [A] 5000	114.9	125.4	118.4	91.6	102.1	95.1	138.1	148.6	141.6	138.1	148.6	141.6
	I _n [A] 6300	136.8	150	141.0	165.1	178.2	169.3	193.1	206.2	197.4	193.1	206.2	197.4

3.2.3 XCP- HP Aluminium

Weight [kg/m]	Type	XCP-HP 3C Al			XCP-HP 4C Al			XCP-HP 5C Al			XCP-HP 2N Al		
	PE version	(PE 1)	(PE 2)	(PE 3)	(PE 1)	(PE 2)	(PE 3)	(PE 1)	(PE 2)	(PE 3)	(PE 1)	(PE 2)	(PE 3)
SINGLE BAR	I _n [A] 630	11.3	14.6	12.3	9.7	13.0	10.8	17.5	20.8	21.0	17.5	20.8	21.0
	I _n [A] 800	11.3	14.6	12.3	9.7	13.0	10.8	17.5	20.8	18.6	17.5	20.8	18.6
	I _n [A] 1000	13.0	16.3	14.1	1.0	14.3	12.1	19.7	23.0	20.8	19.7	23.0	20.8
	I _n [A] 1250	14.6	17.9	15.7	2.2	15.5	13.3	21.7	25.0	22.7	21.7	25.0	22.7
	I _n [A] 1600	18.9	24.1	20.6	5.5	20.7	17.2	22.4	27.5	24.0	22.4	27.5	24.0
	I _n [A] 2000	22.4	28.1	24.3	8.2	23.9	20.0	26.7	32.4	28.5	26.7	32.4	28.5
DOUBLE BAR	I _n [A] 2500	26.7	35.5	29.6	1.6	30.4	24.5	31.8	40.6	34.7	31.8	40.6	34.7
	I _n [A] 3200	35.0	45.2	38.3	7.9	38.2	31.2	42.0	52.3	45.4	42.0	52.3	45.4
	I _n [A] 4000	41.1	52.4	44.8	2.5	43.9	36.2	49.7	61.0	53.3	49.7	61.0	53.3
TRIPLE BAR	I _n [A] 5000	79.7	96.7	85.2	9.1	108	96.5	102.2	119.2	107.8	102.2	119.2	107.8

3.2.4 XCP- HP Copper

Weight [kg/m]	Type	XCP-HP 3C Cu			XCP-HP 4C Cu			XCP-HP 5C Cu			XCP-HP 2N Cu		
	PE version	(PE 1)	(PE 2)	(PE 3)	(PE 1)	(PE 2)	(PE 3)	(PE 1)	(PE 2)	(PE 3)	(PE 1)	(PE 2)	(PE 3)
SINGLE BAR	I _n [A] 800	16.4	19.7	17.5	18.7	22.0	19.7	23.8	27.2	24.9	23.8	27.2	24.9
	I _n [A] 1000	22.2	25.5	23.2	22.9	26.2	23.9	31.1	34.5	32.2	31.1	34.5	32.2
	I _n [A] 1250	24.8	28.1	25.9	24.9	28.2	25.9	34.5	37.8	35.5	34.5	37.8	35.5
	I _n [A] 1600	27.7	32.1	29.1	28.0	32.4	29.5	39.0	43.4	40.4	39.0	43.4	40.4
	I _n [A] 2000	44.7	49.0	46.1	41.6	45.9	43.0	59.9	64.3	61.3	59.9	64.3	61.3
	I _n [A] 2500	55.3	66.7	59.0	52.2	63.5	55.8	74.3	85.6	78.0	74.3	85.6	78.0
DOUBLE BAR	I _n [A] 3200	63.3	72.0	66.1	60.3	69.0	63.1	88.2	96.9	91.1	88.2	96.9	91.1
	I _n [A] 4000	85.5	95.8	89.1	78.6	88.9	82.2	117.3	127.6	120.8	117.3	127.6	120.8
	I _n [A] 5000	117.0	128.3	120.9	103.2	114.5	107.1	157.4	168.8	161.4	157.4	168.8	161.4
TRIPLE BAR	I _n [A] 6300	136.2	151.6	140.4	173.6	189.1	178.7	200.3	215.7	204.5	200.3	215.7	204.5

XCP - Xtra Compact high power busbar system

Reference(s) :

see relative catalogue for detailed reference tables

3.3 Temperature derating

Here below the tables showing the general correction factor for ambient temperature for XCP lines.

For ambient temperatures under -5°C contact Starline technical support.

3.3.1 XCP-S Aluminium and Copper

Daily average ambient temperature	General correction factor for amb. temperatures different from 35°C (k_t)
-5	1.24
0	1.21
5	1.18
10	1.15
15	1.12
20	1.09
25	1.06
30	1.03
35	1
40	0.97
45	0.93
50	0.90

From 35°C it will be necessary to derate the busbar

3.3.2 XCP-HP Aluminium

Daily average ambient temperature	General correction factor for amb. temperatures different from 50°C (k_t)
-5	1.38
0	1.34
5	1.31
10	1.28
15	1.25
20	1.21
25	1.18
30	1.15
35	1.11
40	1.07
45	1.04
50	1.00
55	0.96
60	0.92
65	0.88
70	0.84

From 50°C it will be necessary to derate the busbar

3.3.3 XCP-HP Copper

Daily average ambient temperature	General correction factor for amb. temperatures different from 55°C (k_t)
-5	1.43
0	1.40
5	1.37
10	1.33
15	1.30
20	1.26
25	1.23
30	1.19
35	1.16
40	1.12
45	1.08
50	1.04
55	1.00
60	0.96
65	0.92
70	0.87

From 55°C it will be necessary to derate the busbar

4. CONFORMITY

XCP line has been given Type- Approval Certifications by the most prestigious Electro-technical agencies:

- Certificate of Compliance with Standard: IEC 61439-6
- GOST Type-Approval (Russia)

In order to obtain these recognitions, the XCP range has undergone the following type tests, as confirmation of their quality:

- EI 120 Fire Barrier Test
- IEC 60331-1 / CEI EN 50362 - Fire Resisting Test

The busbar is self-supporting and the degree of impact resistance of the casing which houses this line is the maximum stated in IEC EN60068-2-62: IK10

XCP line accessorised with sprinkler kit make the busbar system resistant to the sprinkler test. Tests under sprinkler conditions are available.

For more information, please contact Starline

XCP ranges and the related tap-off boxes, have obtained the passing of seismic tests at a value of ZPA 1.5g ($\text{ZPA } 1.5\text{g} = 1.5 \times 9.81 \text{ m/s}^2 = 14.71 \text{ m/s}^2$), according to the regulations IEEE Std 693-2018.

The maximum acceleration value obtained corresponds to extremely intense earthquakes.

XCP - Xtra Compact high power busbar system

Reference(s) :

see relative catalogue for detailed reference tables

4.1 Marking

Here below an example of the adhesive label found on each component, with highlighted all the details:

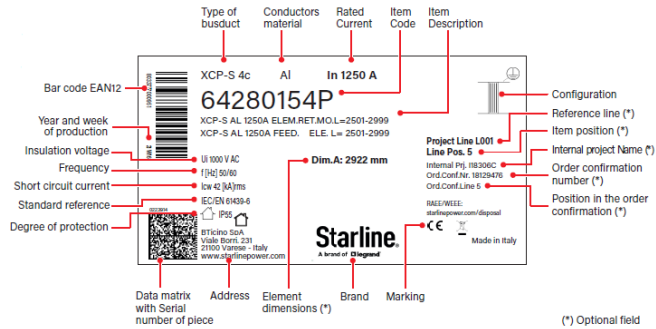

5. ACCESSORIES

All the accessories shown in this section are suitable for bot XCP-S and XCP-HP

5.1 Adapter element (IP68-IP65)

To join XCP and RCP elements.

Here below the dimension scheme

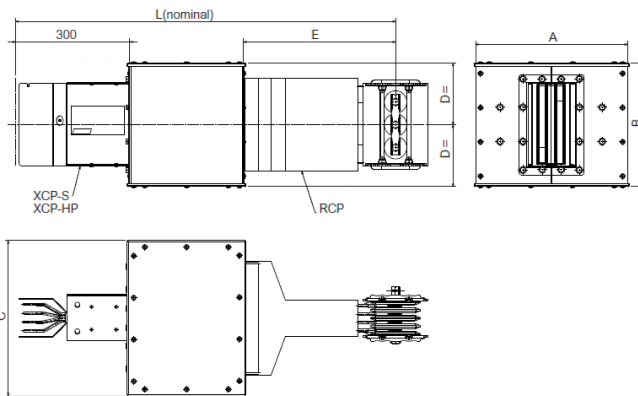

Al	Cu	L	A	B	C	D	E
630 -1000	800 -1250	1000	400	210	310	105	400
1250		1000	400	250	310	125	400
1600	1600 -2000	1000	400	280	310	140	400
2000		1000	400	325	310	162.5	400
	2500	1000	400	380	310	190	400
2500	3200	1000	400	460	310	230	400
3200	4000	1000	400	520	310	260	400
4000	5000	1000	400	560	310	280	400
5000	6300	1250	820	670	460	335	500

XCP-HP 3C - 4C - 5C							
I _n (A)		DIMENSIONS [mm]					
Al	Cu	L	A	B	C	D	E
630 -1000	800 -1250	1000	400	210	310	105	400
1250		1000	400	210	310	125	400
1600		1000	400	280	310	140	400
	1600 -2000	1000	400	250	310	125	400
2000		1000	400	325	310	162.5	400
	2500	1000	400	380	310	190	400
2500	3200	1000	400	460	310	230	400
3200	4000	1000	400	520	310	260	400
4000	5000	1000	400	560	310	280	400
5000	6300	1250	820	820	460	410	500

5.2 Brackets

The brackets enable sturdy installation of the busbar to the system support structures.

Starline offers suitable bracket solutions certified for any type of installation, even in the most difficult environments:

- installations subjected to strong vibrations
- installation in seismic environments

They can be divided into suspension brackets and for vertical elements.

To have a clear vision concerning with choosing criteria and installations rules, please see XCP catalogue and installation and user manual.

5.2.1 Suspension brackets

Edgewise installation

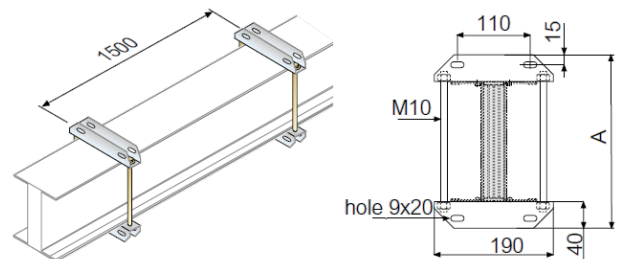

Range	A [mm]			
	XCP-S		XCP-HP	
	Al	Cu	Al	Cu
630	210	-	210	-
800	210	210	210	210
1000	210	210	210	210
1250	250	210	210	210
1600	280	250	280	250
2000	300	280	300	250
2500	460	380	460	300
3200	520	460	520	460
4000	560	520	560	520
5000	670	560	820	560
6300	-	670	-	760

XCP - Xtra Compact high power busbar system

Reference(s) :

see relative catalogue for detailed reference tables

Flat installation

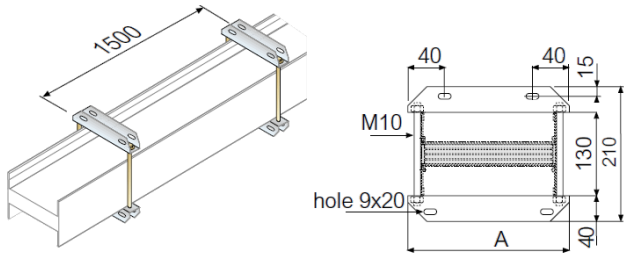

Range	A [mm]			
	XCP-S		XCP-HP	
	Al	Cu	Al	Cu
630	190	-	190	-
800	190	190	190	190
1000	190	190	190	190
1250	315	190	190	190
1600	315	315	315	315
2000	315	315	315	315
2500	430	430	430	315
3200	490	430	490	430
4000	530	490	530	490
5000	640	530	850	530
6300	-	640	-	850

5.2.2 Brackets for vertical elements

They can be divided into different types according to the specific use:

- with bracket and springs
- with bracket
- with springs
- with bracket only
- for Naval applications
- anti-seismic bracket (for details, please contact Starline)

In particular, for brackets with springs, there are 4 possible types as it follows.

Type 1 (B120 / B160)

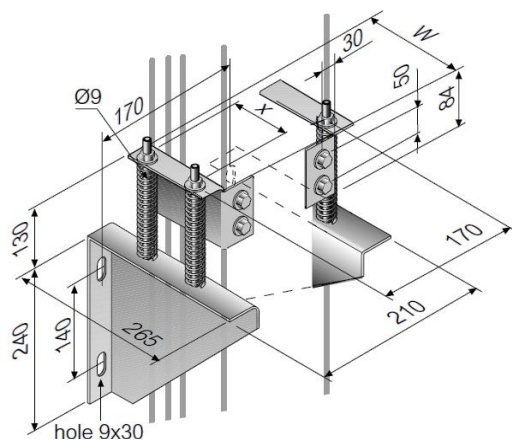

Type 2 (B190 / B210)

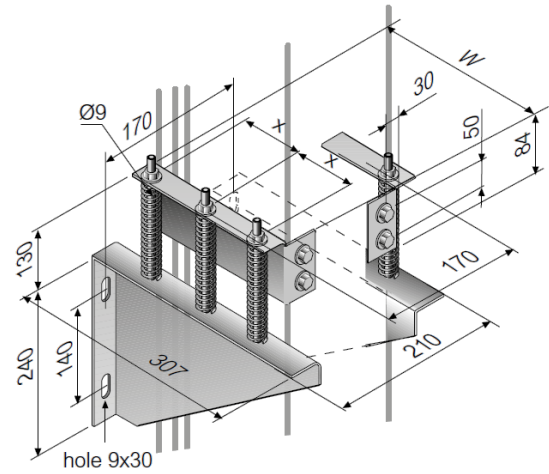

Type 3 (2B120 / 2B160)

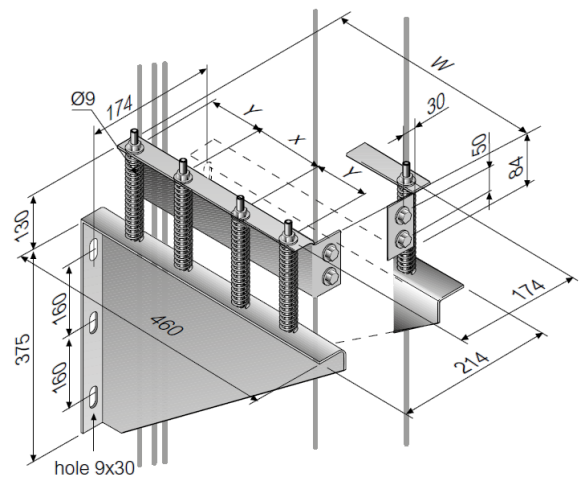

Type 4 (2B190 / 2B210 / 3B160 / 3B190 / 3B210)

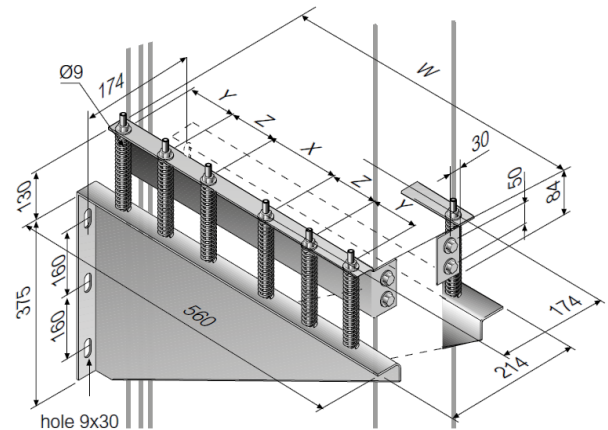

XCP - Xtra Compact high power busbar system

Reference(s) :

see relative catalogue for detailed reference tables

Dimension table for XCP-S

		XCP-S		W [mm]	X [mm]	Y [mm]	Z [mm]
		Al	Cu				
Type 1 (4 springs)	B120	630-1000 A	800-1250 A	130	90	-	-
	B160	1250 A	1600 A	170	120	-	-
Type 2 (6 springs)	B190	1600 A	2000 A	200	80	-	-
	B210	2000 A	-	220	90	-	-
Type 3 (8 springs)	2B120	-	2500 A	300	80	90	-
	2B160	2500 A	3200 A	380	110	115	-
Type 4 (12 springs)	2B190	3200 A	4000 A	440	80	80	80
	2B210	4000 A	5000 A	480	80	90	90
	3B160	5000 A	6300 A	590	120	120	90
	3B190	-	-	680	80	80	180
	3B210	-	-	740	80	80	180

Dimension table for XCP-HP

		XCP-HP		W [mm]	X [mm]	Y [mm]	Z [mm]
		Al	Cu				
Type 1 (4 springs)	B120	630-1250 A	800-1250 A	130	90	-	-
	B160	-	1600-2000 A	170	120	-	-
Type 2 (6 springs)	B190	1600 A	-	200	80	-	-
	B210	2000 A	2500 A	220	90	-	-
Type 3 (8 springs)	2B120	-	-	300	80	90	-
	2B160	2500 A	3200 A	380	110	115	-
Type 4 (12 springs)	2B190	3200 A	4000 A	440	80	80	80
	2B210	4000 A	5000 A	480	80	90	90
	3B160	-	-	590	120	120	90
	3B190	-	6300 A	680	80	80	180
	3B210	5000 A	-	740	80	80	180

To have a clear vision concerning with choosing criteria and installations rules, please see XCP catalogue and installation and user manual.

5.3 End cover IP55

The end cover is the component that ensures an IP55 protection degree at the end of the line.

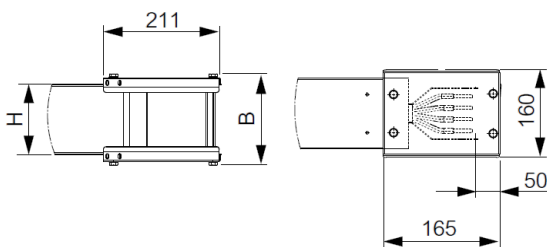

In [A]	XCP-S			
	Al H	Cu B	Al H	Cu B
630	130	170	-	-
800	130	170	130	170
1000	130	170	130	170
1250	170	210	130	170
1600	200	240	170	210
2000	220	260	200	240
2500	380	420	300	340
3200	440	480	380	420
4000	480	520	440	480
5000	590	630	480	520
6300	-	-	590	630

5.4 Protective bellow

Recommended for protection of the interface connection on panel boards, dry-type transformer with enclosure and oil-type transformers

There are 3 different types of protective bellow, to be selected according to the type of busbars.

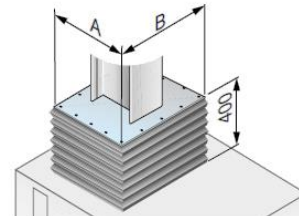

For more details on Protective cover for outdoor applications, please contact Starline

XCP - Xtra Compact high power busbar system

Reference(s) :

see relative catalogue for detailed reference tables

5.5 Flexible braid connections

Flexible braid connections are used to connect the transformer to the connection interface of the busbar when mechanically uncoupling the two elements is required to prevent the transmission of vibrations

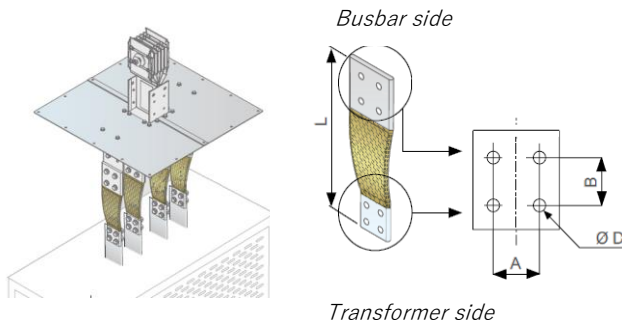

These accessories must be adapted to specific exigences.

When ordering, please specify (dimensions A, B, Ø D) and length L holes on both transformer and busbar side.

The distance between the phases can be designed according to your need.

For customized solutions, with special drillings or for insulated flexible braid, please contact with our technical department.

5.6 ATR elements

ATR are elements used for connection to electric boards or transformers and are similar to straight elements.

These elements may be used for connection to both cast resin and oil transformers, and offer the advantage that the connection interfaces may be installed directly on the vertical section of the transformer terminals, minimizing the time required for the connection of the busbar trunking system to the transformer. Each element is designed based on precise connection specifications supplied by the customer

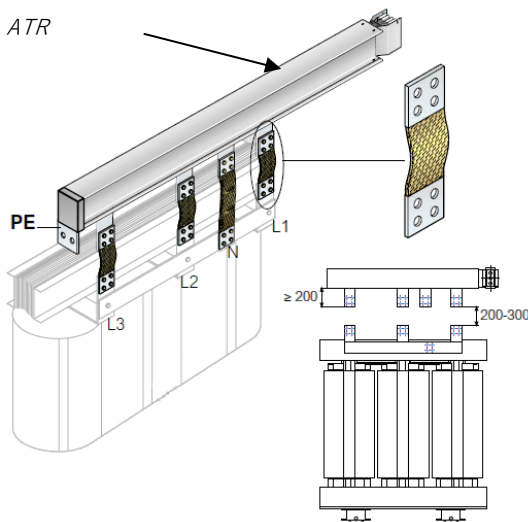

Although designed ad-hoc, ATR elements are still subjected to construction limits. Below are the summarizing tables indicating these values.

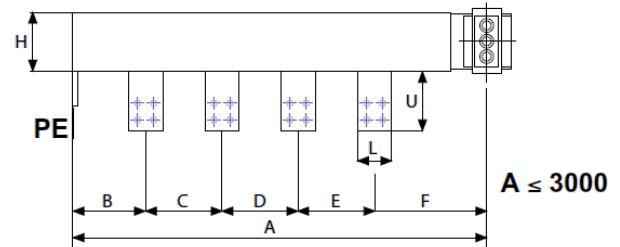

	BAR SIZE	MINIMUM INTERAXES [mm]							
		H	B	C	D	E	F	L	U
SINGLE BAR	B70 - B75 - B80	130	200	165	165	165	335	90	200
	B110	130	200	165	165	165	335	110	200
	B120	130	200	165	165	165	335	120	200
	B160	170	220	205	205	205	355	160	200
	B190	200	245	255	255	255	380	190	200
	B210	220	245	255	255	255	380	210	200
DOUBLE BAR	2B120	300	220	205	205	205	355	120	200
	2B160	380	220	205	205	205	355	160	200
	2B190	440	235	235	235	235	370	190	200
TRIPLE BAR	3B160	590	220	205	205	205	355	160	200
	3B190	680	235	235	235	235	370	190	200
	3B210	740	245	255	255	255	380	210	200

Note: for special dimensions, please contact Starline.

5.7 Tap-off boxes (TOB)

Elements used for connecting and energizing electric loads, suitable for both XCP-S and XCP-HP, from 32A to 630A.

Available in fiber glass or metal sheet and equipped with a sectioning cover that can be installed and removed when the busbar is energised.

TOBs can be:

- MCCB ready: prepared for Legrand MCCB (not provided) and available with hinged cover or with completely removable cover).
- with fuse carriers (fuses not included)
- with switch fuse (equipped with a switch disconnecter AC23) and a fuse carrier. The disconnecter switch is operated through a rotary handle on the cover.
- Empty
- Empty bolt-on type (to be installed on the junction on elements with any rating, with or without tap-off outlets)

According to the rating, TOB can be divided in 3 types (for both fiberglass and metal).

To have a complete vision of the product in terms of perimeter, terminal dimensions and installation rules, please see XCP catalogue pages and installation manual or contact Starline for special requests.

Here below the main dimension overview for each type.

XCP - Xtra Compact high power busbar system

Reference(s) :

see relative catalogue for detailed reference tables

5.7.1 FIBER-GLASS tap-off boxes dimensions [mm]

Type 1 (32A) – with fuse carriers

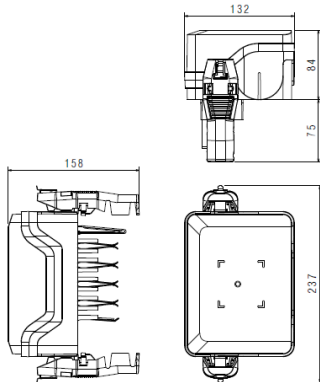

Type 2 (63A / 160A) – MCCB ready

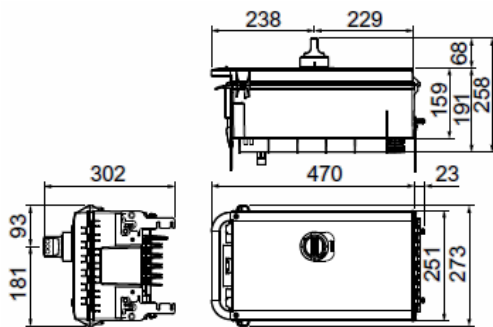

Type 2 (63A / 125A / 160A) – with fuse carriers / empty

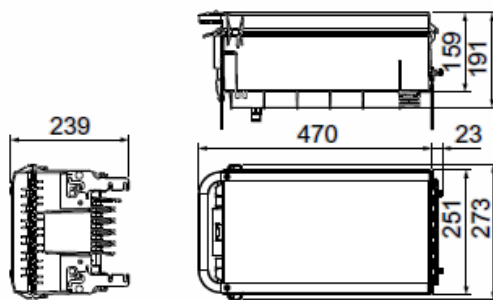

Type 3 (250A) – MCCB ready

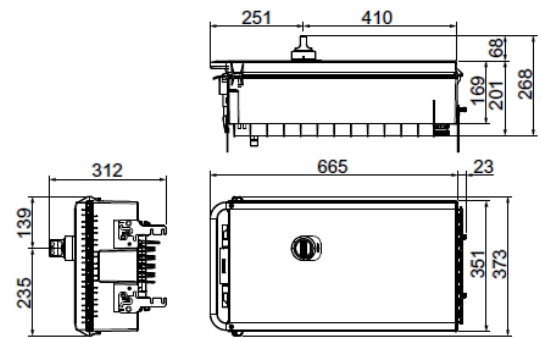

Type 3 (250A) – with fuse carriers / empty

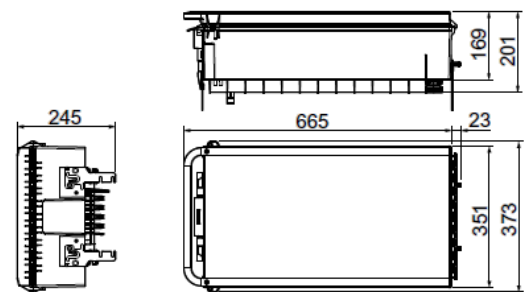

Total dimensions with cover open

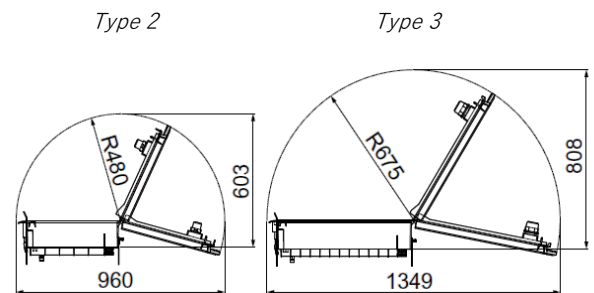

5.7.2 METAL tap-off boxes dimensions [mm]

Type 1 (63A / 125A / 160A) – MCCB ready

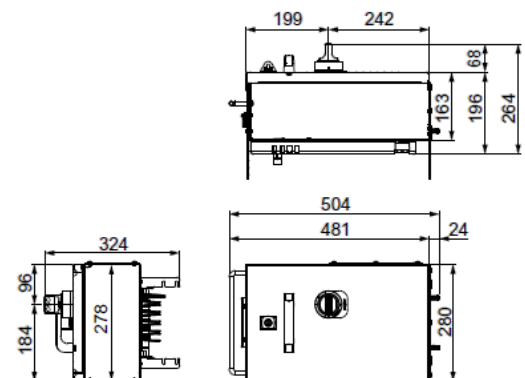

XCP - Xtra Compact high power busbar system

Reference(s) :

see relative catalogue for detailed reference tables

Type 1 (63A / 125A / 160A) – with fuse carriers

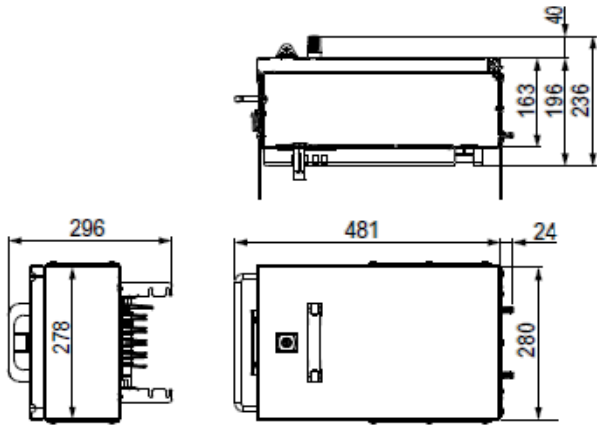

Type 1 (63A / 125A / 160A) – empty

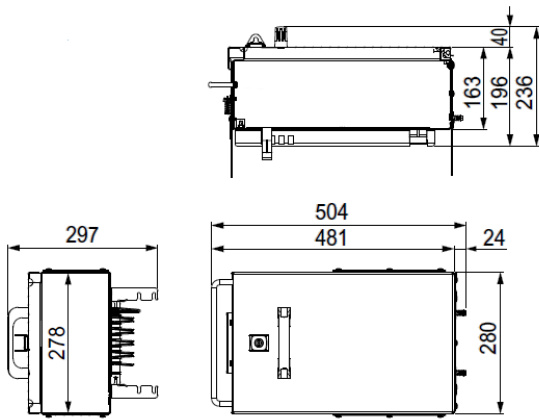

Type 1 – total dimensions with cover open

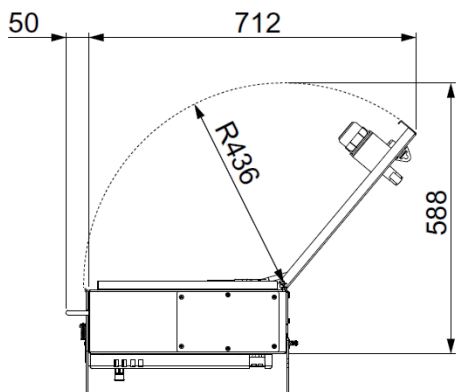

Type 2 (250A) – MCCB ready

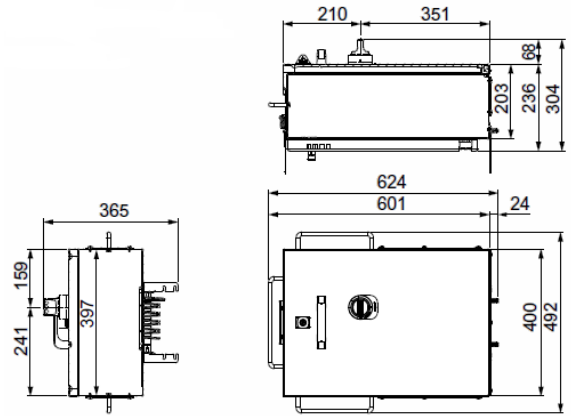

Type 2 (250A) – MCCB ready (removable cover)

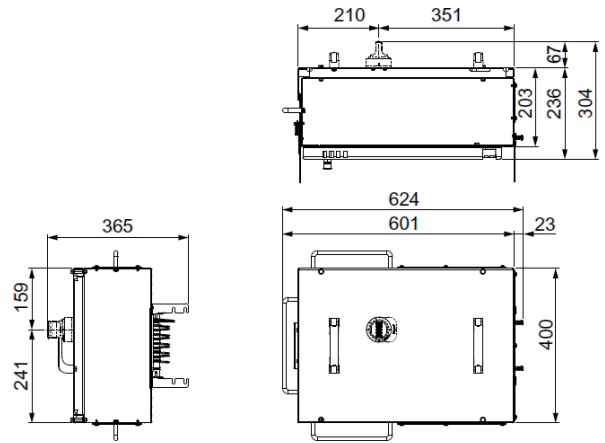

Type 2

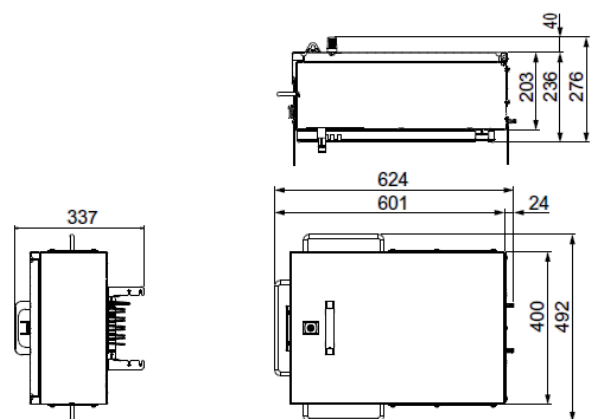

XCP - Xtra Compact high power busbar system

Reference(s) :
see relative catalogue for detailed reference tables

Type 2 - total dimensions with cover open

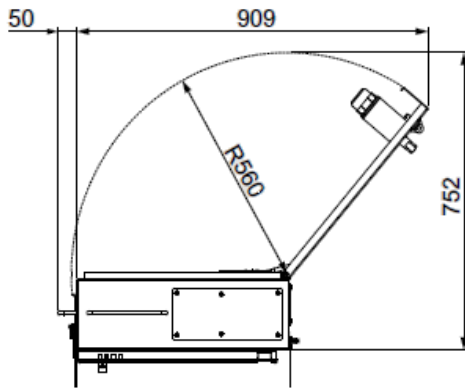

Type 3

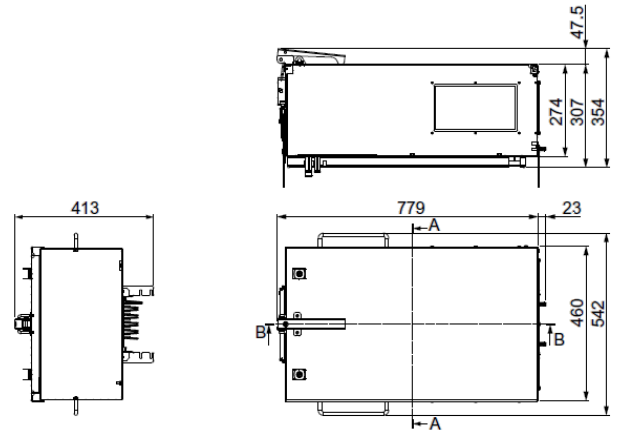
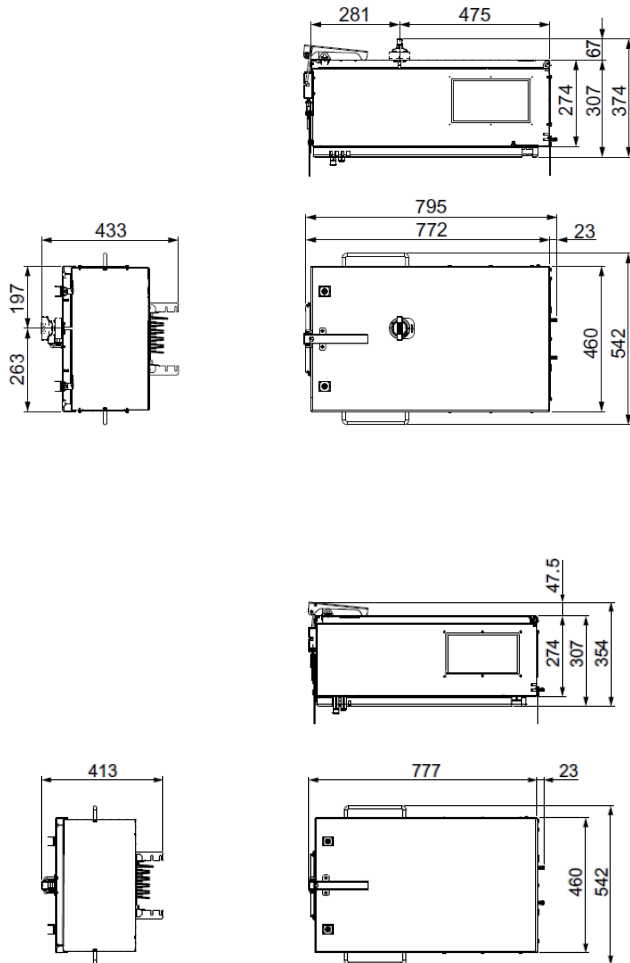

Type 3 - total dimensions with cover open

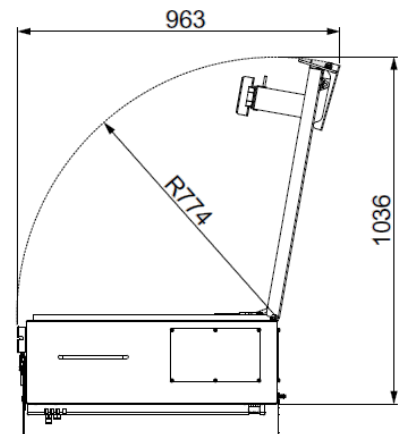

5.7.3 METAL Dimensions [mm]

Rating available are from 125A to 1250A

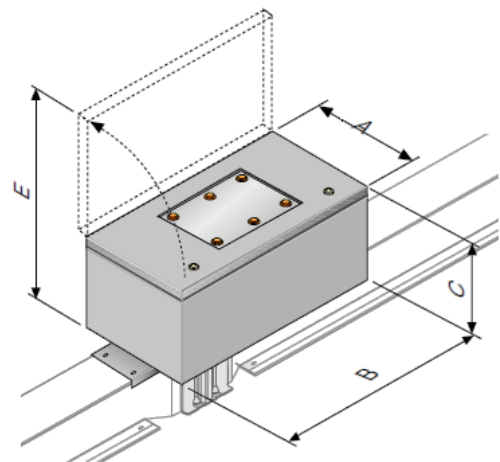

XCP - Xtra Compact high power busbar system

Reference(s) :

see relative catalogue for detailed reference tables

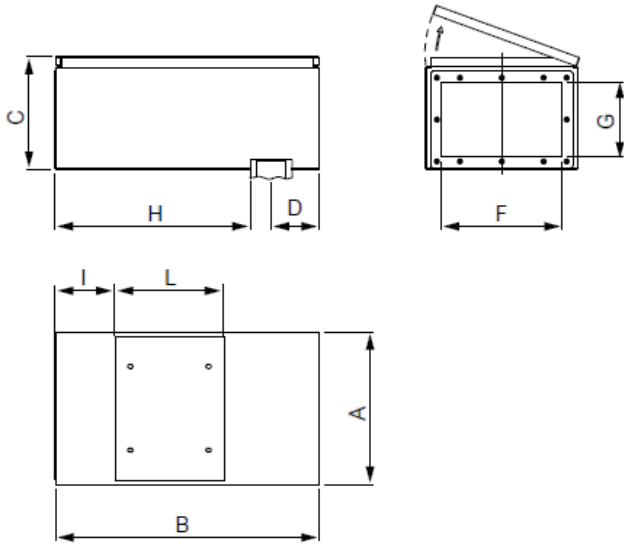

$F \times G \rightarrow$ cable input

H – usable internal space

L – metal internal plate

DIMENSIONS [mm]										
In [A]	A	B	C	D	E	F	G	H	I	L
125										
250	365	630	270	115	630	290	180	465	142	260
400										
630	400	750	280	115	675	290	180	585	227	295
800										
1000	450	1050	300	115	745	380	210	885	254	545
1250										

6. APPENDIX

A) Table on busbar dimension vs ratings

Rated current	OVERALL DIMENSION OF THE BUSBAR L x H [mm]			
	XCP-S		XCP-HP	
	ALUMINIUM	COPPEER	ALUMINIUM	COPPEER
630A	120 x 130	-	125 x 130	-
800A	120 x 130	120 x 130	125 x 130	125 x 130
1000A	120 x 130	120 x 130	125 x 130	125 x 130
1250A	120 x 170	120 x 130	125 x 130	125 x 130
1600A	120 x 200	120 x 170	125 x 200	125 x 170
2000A	120 x 220	120 x 200	125 x 220	125 x 170
2500A	120 x 380	120 x 300	125 x 380	125 x 220
3200A	120 x 440	120 x 380	125 x 440	125 x 380
4000A	120 x 480	120 x 440	125 x 480	125 x 440
5000A	120 x 590	120 x 480	125 x 740	125 x 480
6300A	-	120 x 590	-	125 x 680

SINGLE BAR

DOUBLE BAR

TRIPLE BAR

XCP - Xtra Compact high power busbar system

Reference(s) :
see relative catalogue for detailed reference tables

B) Cover plate and bar drilling details

B.1.1 XCP-S: Cover plate drilling details

Al 630A-2000A
Cu 800A-2000A

Al 2500A-3200A
Cu 2500A-4000A

Al 4000A
Cu 5000A

Al 5000A
Cu 6300A

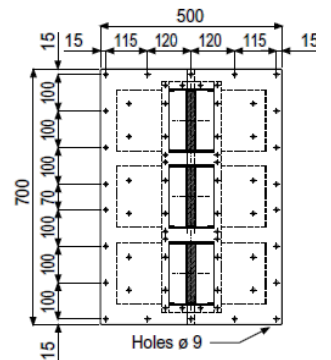
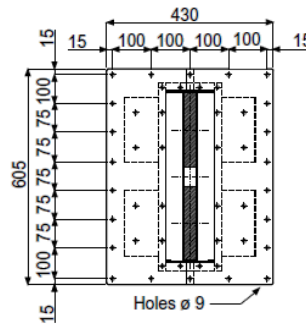
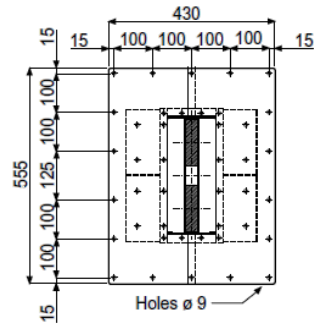
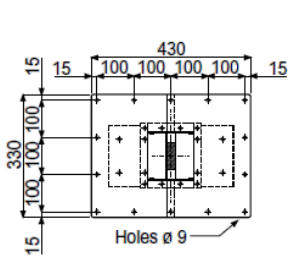

B.1.2 XCP-S: Bar drilling details (side and front view)

Al 630A
Cu 800A

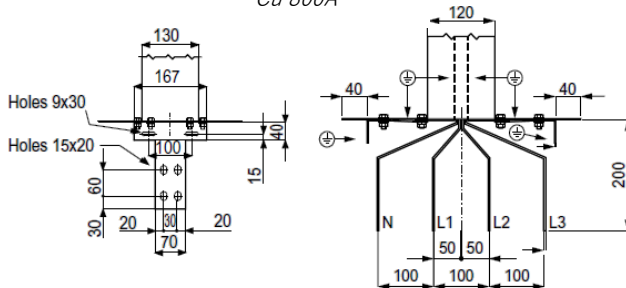

Al 800A
Cu 1000A

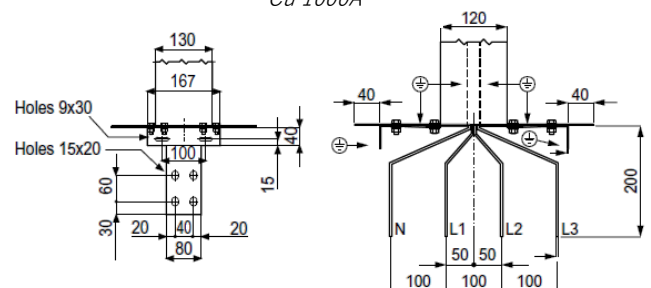

Al 1000A
Cu 1250A

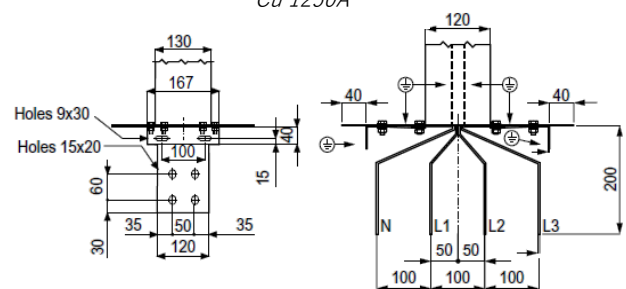

Al 1250A
Cu 1600A

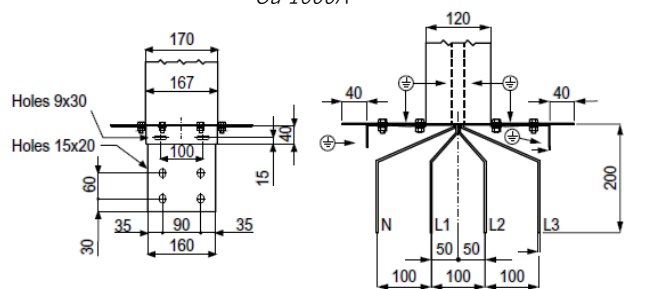

Al 1600A
Cu 2000A

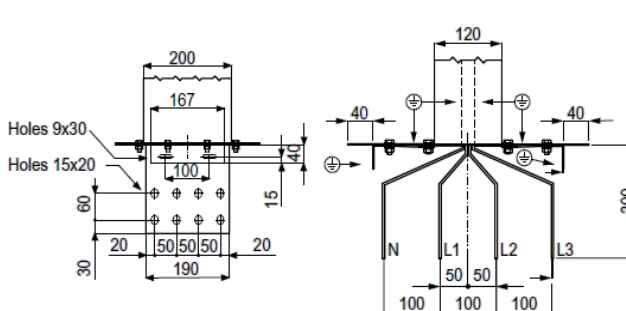

Al 2000A

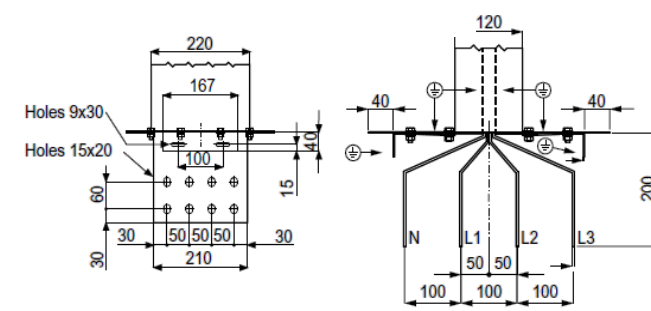

XCP - Xtra Compact high power busbar system

Reference(s) :
see relative catalogue for detailed reference tables

Cu 2500A

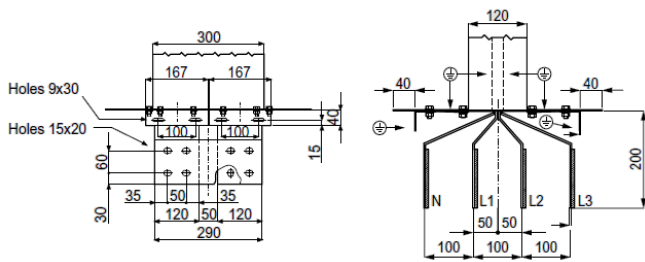

*Al 2500A
Cu 3200A*

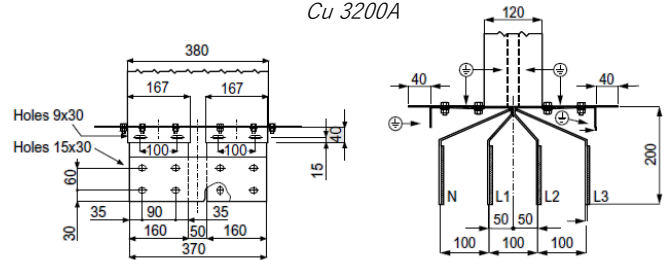

*Al 3200A
Cu 4000A*

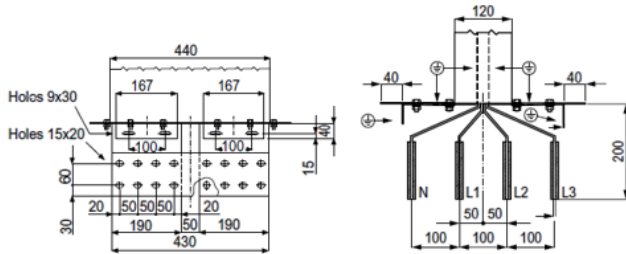

*Al 4000A
Cu 5000A*

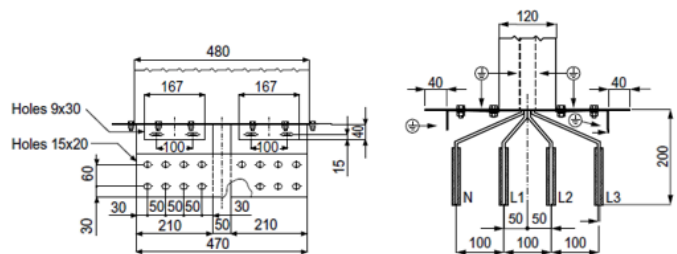

*Al 5000A
Cu 6300A*

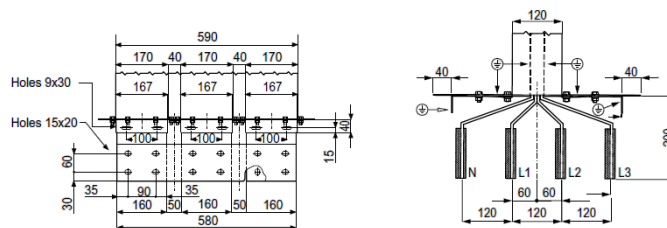

B.2.1 XCP-HP: Cover plate

*Al 630A-2000A
Cu 800A-2000A*

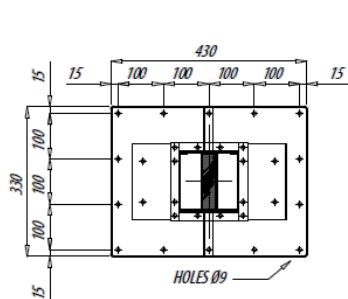

*Al 250A-3200A
Cu 320A-4000A*

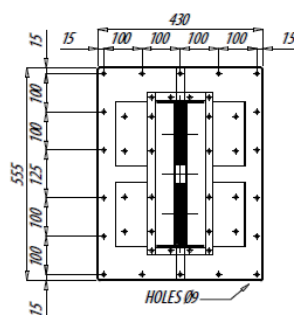

*Al 4000A
Cu 5000A*

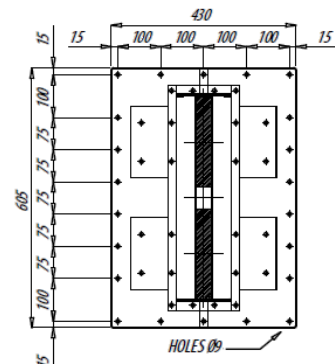

XCP - Xtra Compact high power busbar system

Reference(s) :
see relative catalogue for detailed reference tables

Al 5000A

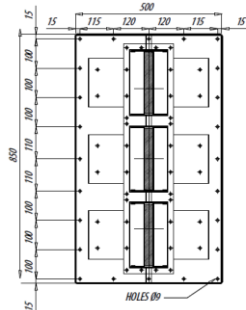

Cu 6300A

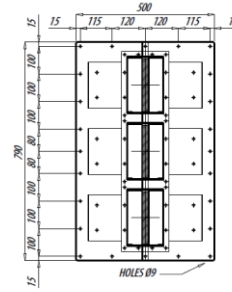

B.2.2 XCP-HP: Bar drilling details (side and front view)

Al 630A - 800A

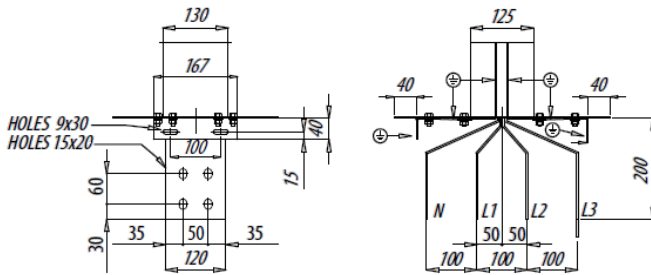

Cu 800A

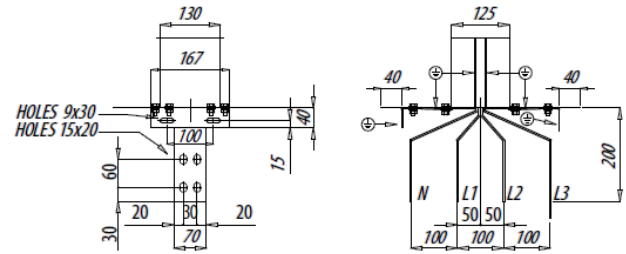

Al 1000A

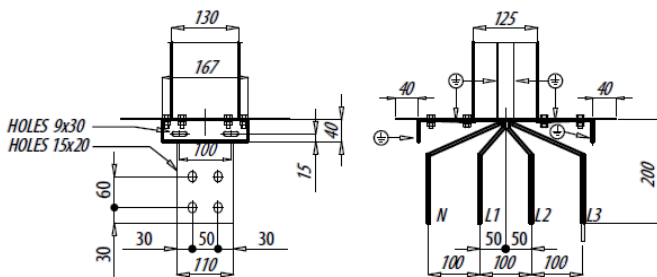

Al 1250A
Cu 1000A-1250A

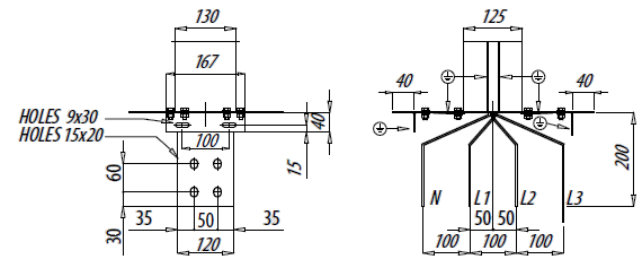

Al 1600A

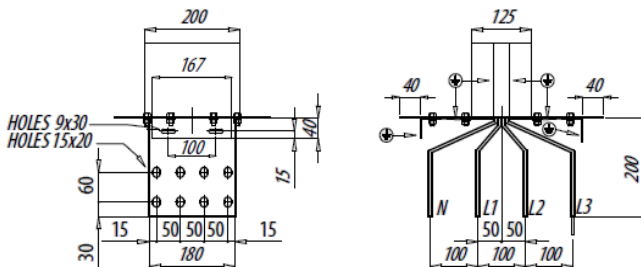

Cu 1600A-2000A

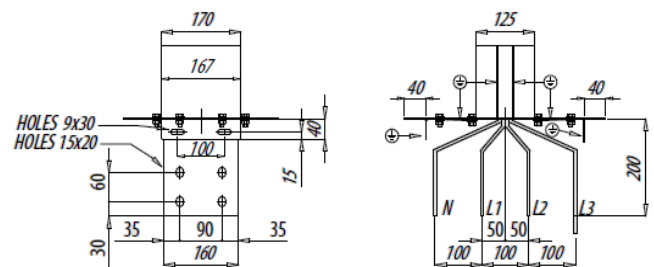

XCP - Xtra Compact high power busbar system

Reference(s) :

see relative catalogue for detailed reference tables

Al 2000A

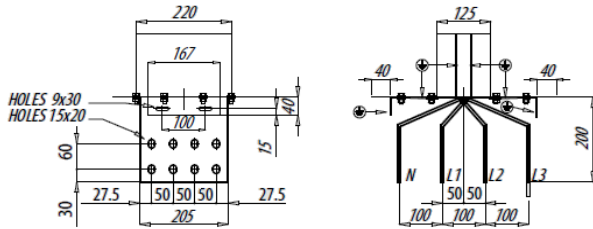

Al 2500A

Cu 3200A

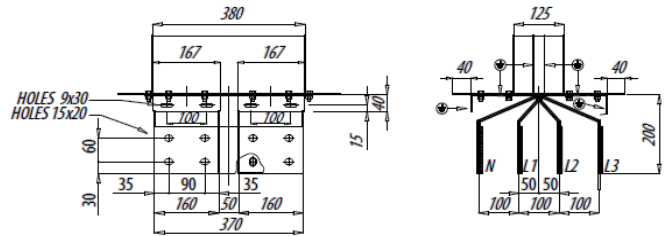

Cu 2500A

Al 3200A

Cu 4000A

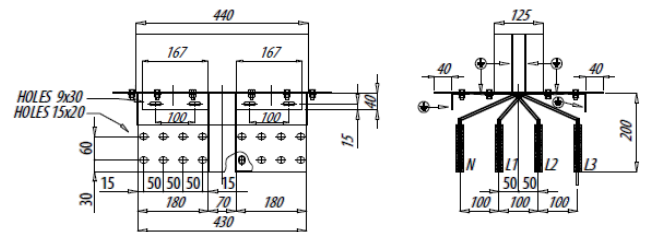
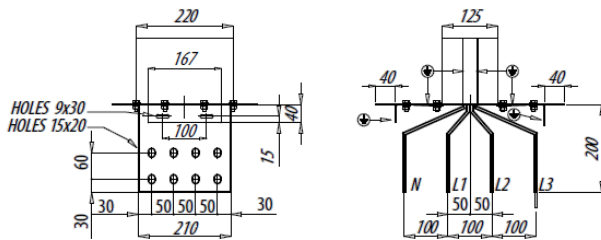

Al 4000A

Al 5000A

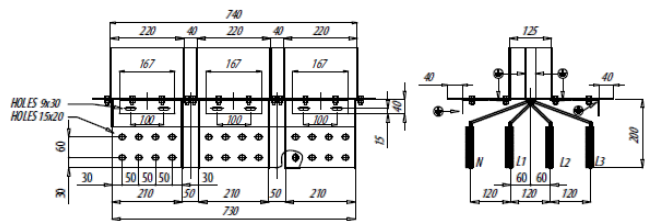
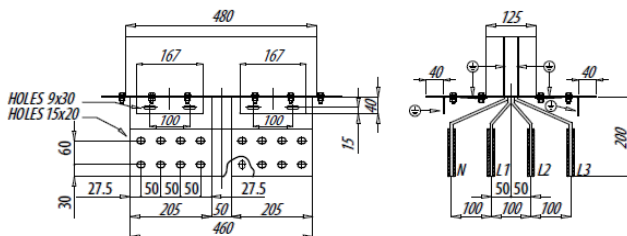

Cu 5000A

Cu 6300A

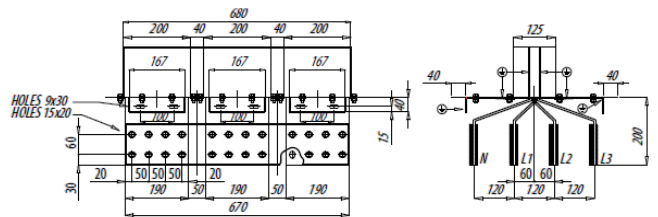
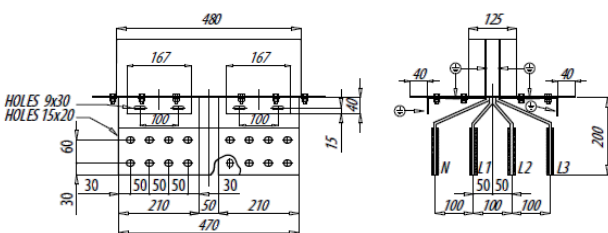

XCP - Xtra Compact high power busbar system

Reference(s) :
see relative catalogue for detailed reference tables

C) Technical data

C.1.1 XCP-S ALUMINIUM (4 Conductors): 3P+N+PE

Rated current	I _n [A]	SINGLE BAR						DOUBLE BAR			TRIPLE BAR
		630	800	1000	1250	1600	2000	2500	3200	4000	5000
Overall dimension of the busbars	L x H [mm]	120 x 130	120 x 130	120 x 130	120 x 170	120 x 200	120 x 220	120 x 380	120 x 440	120 x 480	120 x 590
Rated operational voltage	U _e [V]	1000	1000	1000	1000	1000	1000	1000	1000	1000	1000
Rated insulation voltage	U _i [V]	1000	1000	1000	1000	1000	1000	1000	1000	1000	1000
Frequency	f [Hz]	50/60	50/60	50/60	50/60	50/60	50/60	50/60	50/60	50/60	50/60
Rated short-time current (1 s)	I _{cw} [kA] _{ms}	25***	25***	36	42	42	50	65	80	100	120
Peak current	I _{pk} [kA]	53	53	76	88	88	105	143	176	220	264
Allowable specific energy for three-phase fault	I ² t [MA ² s]	312	312	1296	1764	1764	2500	4225	6400	10000	14400
Rated short-time current of the neutral bar (1 s)	I _{cn} [kA] _{ms}	15***	15***	22	25	25	30	39	48	60	72
Peak current of the neutral bar	I _{pn} [kA]	30	30	46	53	53	63	82	101	132	158
Rated short-time current of the protective circuit (1 s)	I _{cn} [kA] _{ms}	15***	15***	22	25	25	30	39	48	60	72
Peak current of the protective circuit	I _{pn} [kA]	30	30	46	53	53	63	82	101	132	158
Phase resistance at 20°C	R ₂₀ [mΩ/m]	0,140	0,092	0,077	0,057	0,041	0,029	0,029	0,021	0,014	0,011
Phase reactance (50Hz)	X [mΩ/m]	0,023	0,017	0,017	0,016	0,015	0,014	0,011	0,007	0,006	0,005
Phase impedance	Z [mΩ/m]	0,142	0,094	0,079	0,060	0,044	0,032	0,031	0,022	0,016	0,012
Phase resistance at thermal conditions	R [mΩ/m]	0,185	0,122	0,104	0,080	0,058	0,040	0,041	0,030	0,021	0,015
Phase impedance at thermal conditions	Z [mΩ/m]	0,186	0,123	0,105	0,081	0,059	0,043	0,042	0,031	0,022	0,016
Neutral resistance	R ₂₀ [mΩ/m]	0,140	0,092	0,077	0,057	0,041	0,029	0,029	0,021	0,014	0,011
Functional Earth resistance (FE)	R ₂₀ [mΩ/m]	-	-	-	-	-	-	-	-	-	-
Functional Earth reactance (FE)	X [mΩ/m]	-	-	-	-	-	-	-	-	-	-
Resistance of the protective bar (PE 1)	R _{pe} [mΩ/m]	0,132	0,132	0,132	0,119	0,110	0,106	0,078	0,071	0,067	0,040
Resistance of the protective bar (PE 2)	R _{pe} [mΩ/m]	0,049	0,049	0,049	0,038	0,032	0,025	0,021	0,017	0,016	0,013
Resistance of the protective bar (PE 3)	R _{pe} [mΩ/m]	0,084	0,084	0,084	0,064	0,054	0,049	0,035	0,029	0,026	0,021
Reactance of the protective bar	X _{pe} [mΩ/m]	0,080	0,078	0,078	0,048	0,039	0,028	0,020	0,015	0,016	0,014
Resistance of the fault loop (PE 1)	R _o [mΩ/m]	0,272	0,224	0,208	0,176	0,152	0,135	0,107	0,092	0,082	0,051
Resistance of the fault loop (PE 2)	R _o [mΩ/m]	0,190	0,142	0,126	0,095	0,073	0,054	0,049	0,038	0,030	0,023
Resistance of the fault loop (PE 3)	R _o [mΩ/m]	0,224	0,176	0,161	0,121	0,096	0,078	0,064	0,050	0,040	0,032
Reactance of the fault loop (50Hz)	X _o [mΩ/m]	0,10	0,10	0,10	0,06	0,05	0,04	0,03	0,02	0,02	0,02
Impedance of the fault loop (PE 1)	Z _o [mΩ/m]	0,291	0,243	0,229	0,188	0,161	0,142	0,111	0,094	0,085	0,054
Impedance of the fault loop (PE 2)	Z _o [mΩ/m]	0,216	0,171	0,158	0,115	0,091	0,069	0,058	0,044	0,037	0,030
Impedance of the fault loop (PE 3)	Z _o [mΩ/m]	0,247	0,200	0,187	0,137	0,110	0,089	0,071	0,054	0,046	0,037
Zero-sequence short-circuit average resistance phase - N	R _{so} [mΩ/m]	0,187	0,123	0,102	0,077	0,055	0,039	0,038	0,028	0,019	0,014
Zero-sequence short-circuit average reactance phase - N	X _{so} [mΩ/m]	0,031	0,023	0,023	0,021	0,020	0,019	0,015	0,009	0,008	0,007
Zero-sequence short-circuit average impedance phase - N	Z _{so} [mΩ/m]	0,189	0,125	0,105	0,080	0,059	0,043	0,041	0,029	0,021	0,016
Zero-sequence short-circuit average resistance phase - PE	R _{so} [mΩ/m]	0,178	0,162	0,157	0,138	0,124	0,116	0,088	0,078	0,072	0,044
Zero-sequence short-circuit average reactance phase - PE	X _{so} [mΩ/m]	0,031	0,023	0,023	0,021	0,020	0,019	0,015	0,009	0,008	0,007
Zero-sequence short-circuit average impedance phase - PE	Z _{so} [mΩ/m]	0,181	0,164	0,159	0,140	0,126	0,117	0,089	0,079	0,073	0,044
Voltage drop with distributed load ΔV [V/(m*A)]10 ⁻⁴	cosφ = 0,70	126,3	84,4	73,4	58,1	44,1	33,2	31,5	22,4	16,3	12,4
	cosφ = 0,75	133,3	88,9	77,1	60,8	45,9	34,3	32,8	23,3	17,0	12,9
	cosφ = 0,80	140,1	93,3	80,7	63,4	47,6	35,3	34,0	24,2	17,6	13,3
	cosφ = 0,85	146,6	97,5	84,1	65,9	49,2	36,1	35,1	25,1	18,1	13,6
	cosφ = 0,90	152,8	101,5	87,3	68,0	50,5	36,8	36,0	25,8	18,5	13,9
	cosφ = 0,95	158,4	104,9	90,0	69,8	51,4	37,0	36,5	26,4	18,8	14,0
cosφ = 1,00	160,2	105,6	89,9	68,9	49,8	35,0	35,3	25,8	18,0	13,3	
Weight (PE 1)	p [kg/m]	14,3	15,6	16,0	18,9	22,5	27,4	34,1	41,5	50,4	88,3
Weight (PE 2)	p [kg/m]	17,6	18,9	19,3	23,3	27,7	33,9	42,1	51,0	61,0	101,4
Weight (PE 3)	p [kg/m]	15,4	16,7	17,1	20,3	24,2	29,2	36,7	44,6	54,0	92,6
Fire load	[kWh/m]	4,5	5,5	5,5	6,0	8,5	10,5	16,0	19,0	21,0	21,0
Degree of protection	IP	55/65*	55/65*	55/65*	55/65*	55/65*	55/65*	55/65*	55/65*	55/65*	55/65*
Insulation material thermal resistance class		B/F**	B/F**	B/F**	B/F**	B/F**	B/F**	B/F**	B/F**	B/F**	B/F**
Losses for the Joule effect at nominal current	P [W/m]	220	234	311	373	442	485	765	914	1000	1154
Ambient temperature min/MAX (daily average)****	[°C]	-5/50	-5/50	-5/50	-5/50	-5/50	-5/50	-5/50	-5/50	-5/50	-5/50

* IP65 available under request for feeder lines

** Class F available under request

*** I_{cn} value at 0.5 s

**** Over 35° C it will be necessary to derate the busbar and for ambient temperatures under -5° C contact the technical support.

The data on this page refer to the 50 Hz frequency. For 60 Hz, please contact Starline.

XCP - Xtra Compact high power busbar system

Reference(s) :

see relative catalogue for detailed reference tables

C) Technical data

C.1.2 XCP-S ALUMINIUM (5 Conductors - clean earth): 3P+N+PE+FE

Rated current	I _n [A]	SINGLE BAR						DOUBLE BAR			TRIPLE BAR
		630	800	1000	1250	1600	2000	2500	3200	4000	5000
Overall dimension of the busbars	L x H [mm]	120 x 130	120 x 130	120 x 130	120 x 170	120 x 200	120 x 220	120 x 380	120 x 440	120 x 480	120 x 590
Rated operational voltage	U _e [V]	1000	1000	1000	1000	1000	1000	1000	1000	1000	1000
Rated insulation voltage	U _i [V]	1000	1000	1000	1000	1000	1000	1000	1000	1000	1000
Frequency	f [Hz]	50/60	50/60	50/60	50/60	50/60	50/60	50/60	50/60	50/60	50/60
Rated short-time current (1 s)	I _{cw} [kA] _{1ms}	25***	25***	36	42	42	50	65	80	100	120
Peak current	I _{pk} [kA]	53	53	76	88	88	105	143	176	220	264
Allowable specific energy for three-phase fault	i ² t [MA ² s]	312	312	1296	1764	1764	2500	4225	6400	10000	14400
Rated short-time current of the neutral bar (1 s)	I _{cn} [kA] _{1ms}	15***	15***	22	25	25	30	39	48	60	72
Peak current of the neutral bar	I _{pk} [kA]	30	30	46	53	53	63	82	101	132	158
Rated short-time current of the protective circuit (1 s)	I _{cn} [kA] _{1ms}	15***	15***	22	25	25	30	39	48	60	72
Peak current of the protective circuit	I _{pk} [kA]	30	30	46	53	53	63	82	101	132	158
Phase resistance at 20°C	R ₂₀ [mΩ/m]	0,140	0,092	0,077	0,057	0,041	0,029	0,029	0,021	0,014	0,011
Phase reactance (50Hz)	X [mΩ/m]	0,023	0,017	0,017	0,016	0,015	0,014	0,011	0,007	0,006	0,005
Phase impedance	Z [mΩ/m]	0,142	0,094	0,079	0,060	0,044	0,032	0,031	0,022	0,016	0,012
Phase resistance at thermal conditions	R [mΩ/m]	0,185	0,122	0,104	0,080	0,058	0,040	0,041	0,030	0,021	0,015
Phase impedance at thermal conditions	Z [mΩ/m]	0,186	0,123	0,105	0,081	0,059	0,043	0,042	0,031	0,022	0,016
Neutral resistance	R ₂₀ [mΩ/m]	0,140	0,092	0,077	0,057	0,041	0,029	0,029	0,021	0,014	0,011
Functional Earth resistance (FE)	R ₂₀ [mΩ/m]	0,140	0,092	0,077	0,057	0,041	0,029	0,029	0,021	0,014	0,011
Functional Earth reactance (FE)	X [mΩ/m]	0,023	0,017	0,017	0,016	0,015	0,014	0,011	0,007	0,006	0,005
Resistance of the protective bar (PE 1)	R _{pe} [mΩ/m]	0,132	0,132	0,132	0,119	0,110	0,106	0,078	0,071	0,067	0,040
Resistance of the protective bar (PE 2)	R _{pe} [mΩ/m]	0,049	0,049	0,049	0,038	0,032	0,025	0,021	0,017	0,016	0,013
Resistance of the protective bar (PE 3)	R _{pe} [mΩ/m]	0,084	0,084	0,084	0,064	0,054	0,049	0,035	0,029	0,026	0,021
Reactance of the protective bar	X _{pe} [mΩ/m]	0,080	0,078	0,078	0,048	0,039	0,028	0,020	0,015	0,016	0,014
Resistance of the fault loop (PE 1)	R _o [mΩ/m]	0,208	0,146	0,125	0,096	0,071	0,052	0,050	0,037	0,026	0,019
Resistance of the fault loop (PE 2)	R _o [mΩ/m]	0,177	0,124	0,107	0,080	0,059	0,042	0,041	0,030	0,022	0,016
Resistance of the fault loop (PE 3)	R _o [mΩ/m]	0,193	0,136	0,117	0,088	0,065	0,047	0,044	0,033	0,024	0,018
Reactance of the fault loop (50Hz)	X _o [mΩ/m]	0,10	0,10	0,10	0,06	0,05	0,04	0,03	0,02	0,02	0,02
Impedance of the fault loop (PE 1)	Z _o [mΩ/m]	0,232	0,174	0,157	0,116	0,089	0,067	0,059	0,043	0,034	0,027
Impedance of the fault loop (PE 2)	Z _o [mΩ/m]	0,205	0,156	0,143	0,103	0,080	0,060	0,051	0,037	0,031	0,025
Impedance of the fault loop (PE 3)	Z _o [mΩ/m]	0,218	0,166	0,151	0,109	0,084	0,063	0,054	0,039	0,032	0,026
Zero-sequence short-circuit average resistance phase - N	R _o [mΩ/m]	0,187	0,123	0,102	0,077	0,055	0,039	0,038	0,028	0,019	0,014
Zero-sequence short-circuit average reactance phase - N	X _o [mΩ/m]	0,031	0,023	0,023	0,021	0,020	0,019	0,015	0,009	0,008	0,007
Zero-sequence short-circuit average impedance phase - N	Z _o [mΩ/m]	0,189	0,125	0,105	0,080	0,059	0,043	0,041	0,029	0,021	0,016
Zero-sequence short-circuit average resistance phase - PE	R _o [mΩ/m]	0,187	0,123	0,102	0,077	0,055	0,039	0,038	0,028	0,019	0,014
Zero-sequence short-circuit average reactance phase - PE	X _o [mΩ/m]	0,031	0,023	0,023	0,021	0,020	0,019	0,015	0,009	0,008	0,007
Zero-sequence short-circuit average impedance phase - PE	Z _o [mΩ/m]	0,189	0,125	0,105	0,080	0,059	0,043	0,041	0,029	0,021	0,016
Voltage drop with distributed load ΔV [V/(m*A)]10 ⁻⁴	cosφ = 0,70	126,3	84,4	73,4	58,1	44,1	33,2	31,5	22,4	16,3	12,4
	cosφ = 0,75	133,3	88,9	77,1	60,8	45,9	34,3	32,8	23,3	17,0	12,9
	cosφ = 0,80	140,1	93,3	80,7	63,4	47,6	35,3	34,0	24,2	17,6	13,3
	cosφ = 0,85	146,6	97,5	84,1	65,9	49,2	36,1	35,1	25,1	18,1	13,6
	cosφ = 0,90	152,8	101,5	87,3	68,0	50,5	36,8	36,0	25,8	18,5	13,9
	cosφ = 0,95	158,4	104,9	90,0	69,8	51,4	37,0	36,5	26,4	18,8	14,0
	cosφ = 1,00	160,2	105,6	89,9	68,9	49,8	35,0	35,3	25,8	18,0	13,3
Weight (PE 1)	p [kg/m]	15,3	17,0	17,6	20,9	25,2	31,1	38,3	47,1	58,0	98,2
Weight (PE 2)	p [kg/m]	18,6	20,3	20,9	25,3	30,3	37,6	46,3	56,6	68,6	111,3
Weight (PE 3)	p [kg/m]	16,4	18,0	18,7	22,3	26,9	33,0	40,9	50,2	61,5	102,5
Fire load	[kWh/m]	5,6	6,9	6,9	7,5	10,6	13,1	20,0	23,8	26,3	27,3
Degree of protection	IP	55/65*	55/65*	55/65*	55/65*	55/65*	55/65*	55/65*	55/65*	55/65*	55/65*
Insulation material thermal resistance class		B/F**	B/F**	B/F**	B/F**	B/F**	B/F**	B/F**	B/F**	B/F**	B/F**
Losses for the Joule effect at nominal current	P [W/m]	220	234	311	373	442	485	765	914	1000	1154
Ambient temperature min/MAX (daily average)****	[°C]	-5/50	-5/50	-5/50	-5/50	-5/50	-5/50	-5/50	-5/50	-5/50	-5/50

* IP65 available under request for feeder lines

** Class F available under request

*** I_{cn} value at 0.5 s

**** Over 35° C it will be necessary to derate the busbar and for ambient temperatures under -5° C

contact the technical support.

The data on this page refer to the 50 Hz frequency. For 60 Hz, please contact Starline.

XCP - Xtra Compact high power busbar system

Reference(s) :
see relative catalogue for detailed reference tables

C) Technical data

C.1.3 XCP-S ALUMINIUM (5 Conductors – double neutral): 3P+2N+PE

Rated current	I _n [A]	SINGLE BAR						DOUBLE BAR			TRIPLE BAR
		630	800	1000	1250	1600	2000	2500	3200	4000	5000
Overall dimension of the busbars	L x H [mm]	120 x 130	120 x 130	120 x 130	120 x 170	120 x 200	120 x 220	120 x 380	120 x 440	120 x 480	120 x 590
Rated operational voltage	U _e [V]	1000	1000	1000	1000	1000	1000	1000	1000	1000	1000
Rated insulation voltage	U _i [V]	1000	1000	1000	1000	1000	1000	1000	1000	1000	1000
Frequency	f [Hz]	50/60	50/60	50/60	50/60	50/60	50/60	50/60	50/60	50/60	50/60
Rated short-time current (1 s)	I _{cw} [kA] _{ms}	25***	25***	36	42	42	50	65	80	100	120
Peak current	I _{pk} [kA]	53	53	76	88	88	105	143	176	220	264
Allowable specific energy for three-phase fault	I ² t [MA ² s]	312	312	1296	1764	1764	2500	4225	6400	10000	14400
Rated short-time current of the neutral bar (1 s)	I _{cn} [kA] _{ms}	15***	15***	22	25	25	30	39	48	60	72
Peak current of the neutral bar	I _{pk} [kA]	30	30	46	53	53	63	82	101	132	158
Rated short-time current of the protective circuit (1 s)	I _{cp} [kA] _{ms}	15***	15***	22	25	25	30	39	48	60	72
Peak current of the protective circuit	I _{pk} [kA]	30	30	46	53	53	63	82	101	132	158
Phase resistance at 20°C	R ₂₀ [mΩ/m]	0,340	0,092	0,077	0,057	0,041	0,029	0,029	0,021	0,014	0,011
Phase reactance (50Hz)	X [mΩ/m]	0,023	0,017	0,017	0,016	0,015	0,014	0,011	0,007	0,006	0,005
Phase impedance	Z [mΩ/m]	0,142	0,094	0,079	0,060	0,044	0,032	0,031	0,022	0,016	0,012
Phase resistance at thermal conditions	R [mΩ/m]	0,185	0,122	0,104	0,080	0,058	0,040	0,041	0,030	0,021	0,015
Phase impedance at thermal conditions	Z [mΩ/m]	0,186	0,123	0,105	0,081	0,059	0,043	0,042	0,031	0,022	0,016
Neutral resistance	R ₂₀ [mΩ/m]	0,070	0,046	0,038	0,029	0,021	0,014	0,014	0,010	0,007	0,005
Functional Earth resistance (FE)	R ₂₀ [mΩ/m]	-	-	-	-	-	-	-	-	-	-
Functional Earth reactance (FE)	X [mΩ/m]	-	-	-	-	-	-	-	-	-	-
Resistance of the protective bar (PE 1)	R _{PE} [mΩ/m]	0,132	0,132	0,132	0,119	0,110	0,106	0,078	0,071	0,067	0,040
Resistance of the protective bar (PE 2)	R _{PE} [mΩ/m]	0,049	0,049	0,049	0,038	0,032	0,025	0,021	0,017	0,016	0,013
Resistance of the protective bar (PE 3)	R _{PE} [mΩ/m]	0,084	0,084	0,084	0,064	0,054	0,049	0,035	0,029	0,026	0,021
Reactance of the protective bar	X _{PE} [mΩ/m]	0,080	0,078	0,078	0,048	0,039	0,028	0,020	0,015	0,016	0,014
Resistance of the fault loop (PE 1)	R _{fa} [mΩ/m]	0,272	0,224	0,208	0,176	0,152	0,135	0,107	0,092	0,082	0,051
Resistance of the fault loop (PE 2)	R _{fa} [mΩ/m]	0,190	0,142	0,126	0,095	0,073	0,054	0,049	0,038	0,030	0,023
Resistance of the fault loop (PE 3)	R _{fa} [mΩ/m]	0,224	0,176	0,161	0,121	0,096	0,078	0,064	0,050	0,040	0,032
Reactance of the fault loop (50Hz)	X _{fa} [mΩ/m]	0,10	0,10	0,10	0,06	0,05	0,04	0,03	0,02	0,02	0,02
Impedance of the fault loop (PE 1)	Z _{fa} [mΩ/m]	0,291	0,243	0,229	0,188	0,161	0,142	0,111	0,094	0,085	0,054
Impedance of the fault loop (PE 2)	Z _{fa} [mΩ/m]	0,216	0,171	0,158	0,115	0,091	0,069	0,058	0,044	0,037	0,030
Impedance of the fault loop (PE 3)	Z _{fa} [mΩ/m]	0,247	0,200	0,187	0,137	0,110	0,089	0,071	0,054	0,046	0,037
Zero-sequence short-circuit average resistance phase - N	R ₀ [mΩ/m]	0,117	0,077	0,064	0,048	0,034	0,024	0,024	0,017	0,012	0,009
Zero-sequence short-circuit average reactance phase - N	X ₀ [mΩ/m]	0,019	0,014	0,014	0,013	0,013	0,012	0,009	0,006	0,005	0,004
Zero-sequence short-circuit average impedance phase - N	Z ₀ [mΩ/m]	0,118	0,078	0,066	0,050	0,037	0,027	0,026	0,018	0,013	0,010
Zero-sequence short-circuit average resistance phase - PE	R ₀ [mΩ/m]	0,178	0,162	0,157	0,138	0,124	0,116	0,088	0,078	0,072	0,044
Zero-sequence short-circuit average reactance phase - PE	X ₀ [mΩ/m]	0,031	0,023	0,023	0,021	0,020	0,019	0,015	0,009	0,008	0,007
Zero-sequence short-circuit average impedance phase - PE	Z ₀ [mΩ/m]	0,181	0,164	0,159	0,140	0,126	0,117	0,089	0,079	0,073	0,044
Voltage drop with distributed load ΔV [V/(m*A)]10 ⁻⁴	cosφ = 0,70	126,3	84,4	73,4	58,1	44,1	33,2	31,5	22,4	16,3	12,4
	cosφ = 0,75	133,3	88,9	77,1	60,8	45,9	34,3	32,8	23,3	17,0	12,9
	cosφ = 0,80	140,1	93,3	80,7	63,4	47,6	35,3	34,0	24,2	17,6	13,3
	cosφ = 0,85	146,6	97,5	84,1	65,9	49,2	36,1	35,1	25,1	18,1	13,6
	cosφ = 0,90	152,8	101,5	87,3	68,0	50,5	36,8	36,0	25,8	18,5	13,9
	cosφ = 0,95	158,4	104,9	90,0	69,8	51,4	37,0	36,5	26,4	18,8	14,0
	cosφ = 1,00	160,2	105,6	89,9	68,9	49,8	35,0	35,3	25,8	18,0	13,3
Weight (PE 1)	p [kg/m]	15,3	17,0	17,6	20,9	25,2	31,1	38,3	47,1	58,0	98,2
Weight (PE 2)	p [kg/m]	18,6	20,3	20,9	25,3	30,3	37,6	46,3	56,6	68,6	111,3
Weight (PE 3)	p [kg/m]	16,4	18,0	18,7	22,3	26,9	33,0	40,9	50,2	61,5	102,5
Fire load	[kWh/m]	5,6	6,9	6,9	7,5	10,6	13,1	20,0	23,8	26,3	27,3
Degree of protection	IP	55/65*	55/65*	55/65*	55/65*	55/65*	55/65*	55/65*	55/65*	55/65*	55/65*
Insulation material thermal resistance class		B/F**	B/F**	B/F**	B/F**	B/F**	B/F**	B/F**	B/F**	B/F**	B/F**
Losses for the Joule effect at nominal current	P [W/m]	220	234	311	373	442	485	765	914	1000	1154
Ambient temperature min/MAX (daily average)****	[°C]	-5/50	-5/50	-5/50	-5/50	-5/50	-5/50	-5/50	-5/50	-5/50	-5/50

* IP65 available under request for feeder lines

** Class F available under request

*** I_{cn} value at 0.5 s

**** Over 35° C it will be necessary to derate the busbar and for ambient temperatures under -5° C contact the technical support.

The data on this page refer to the 50 Hz frequency. For 60 Hz, please contact Starline.

XCP - Xtra Compact high power busbar system

Reference(s) :
see relative catalogue for detailed reference tables

C) Technical data

C.1.4 XCP-S ALUMINIUM (3 Conductors) : 3P+PE

Rated current	I _n [A]	SINGLE BAR						DOUBLE BAR			TRIPLE BAR
		630	800	1000	1250	1600	2000	2500	3200	4000	5000
Overall dimension of the busbars	L x H [mm]	120 x 130	120 x 130	120 x 130	120 x 170	120 x 200	120 x 220	120 x 380	120 x 440	120 x 480	120 x 590
Rated operational voltage	U _e [V]	1000	1000	1000	1000	1000	1000	1000	1000	1000	1000
Rated insulation voltage	U _i [V]	1000	1000	1000	1000	1000	1000	1000	1000	1000	1000
Frequency	f [Hz]	50/60	50/60	50/60	50/60	50/60	50/60	50/60	50/60	50/60	50/60
Rated short-time current (1 s)	I _{cw} [kA] _{ms}	25***	25***	36	42	42	50	65	80	100	120
Peak current	I _{pk} [kA]	53	53	76	88	88	105	143	176	220	264
Allowable specific energy for three-phase fault	I ² t [MA ² s]	312	312	1296	1764	1764	2500	4225	6400	10000	14400
Rated short-time current of the neutral bar (1 s)	I _{cn} [kA] _{ms}	-	-	-	-	-	-	-	-	-	-
Peak current of the neutral bar	I _{pn} [kA]	-	-	-	-	-	-	-	-	-	-
Rated short-time current of the protective circuit (1 s)	I _{cp} [kA] _{ms}	15***	15***	22	25	25	30	39	48	60	72
Peak current of the protective circuit	I _{pk} [kA]	30	30	46	53	53	63	82	101	132	158
Phase resistance at 20°C	R ₂₀ [mΩ/m]	0,140	0,092	0,077	0,057	0,041	0,029	0,029	0,021	0,014	0,011
Phase reactance (50Hz)	X [mΩ/m]	0,023	0,017	0,017	0,016	0,015	0,014	0,011	0,007	0,006	0,005
Phase impedance	Z [mΩ/m]	0,142	0,094	0,079	0,060	0,044	0,032	0,031	0,022	0,016	0,012
Phase resistance at thermal conditions	R [mΩ/m]	0,185	0,122	0,104	0,080	0,058	0,040	0,041	0,030	0,021	0,015
Phase impedance at thermal conditions	Z [mΩ/m]	0,186	0,123	0,105	0,081	0,059	0,043	0,042	0,031	0,022	0,016
Neutral resistance	R ₂₀ [mΩ/m]	-	-	-	-	-	-	-	-	-	-
Functional Earth resistance (FE)	R ₂₀ [mΩ/m]	-	-	-	-	-	-	-	-	-	-
Functional Earth reactance (FE)	X [mΩ/m]	-	-	-	-	-	-	-	-	-	-
Resistance of the protective bar (PE 1)	R _{pe} [mΩ/m]	0,132	0,132	0,132	0,119	0,110	0,106	0,078	0,071	0,067	0,040
Resistance of the protective bar (PE 2)	R _{pe} [mΩ/m]	0,049	0,049	0,049	0,038	0,032	0,025	0,021	0,017	0,016	0,013
Resistance of the protective bar (PE 3)	R _{pe} [mΩ/m]	0,084	0,084	0,084	0,064	0,054	0,049	0,035	0,029	0,026	0,021
Reactance of the protective bar	X _{pe} [mΩ/m]	0,080	0,078	0,078	0,048	0,039	0,028	0,020	0,015	0,016	0,014
Resistance of the fault loop (PE 1)	R _o [mΩ/m]	0,272	0,224	0,208	0,176	0,152	0,135	0,107	0,092	0,082	0,051
Resistance of the fault loop (PE 2)	R _o [mΩ/m]	0,190	0,142	0,126	0,095	0,073	0,054	0,049	0,038	0,030	0,023
Resistance of the fault loop (PE 3)	R _o [mΩ/m]	0,224	0,176	0,161	0,121	0,096	0,078	0,064	0,050	0,040	0,032
Reactance of the fault loop (50Hz)	X _o [mΩ/m]	0,10	0,10	0,10	0,06	0,05	0,04	0,03	0,02	0,02	0,02
Impedance of the fault loop (PE 1)	Z _o [mΩ/m]	0,291	0,243	0,229	0,188	0,161	0,142	0,111	0,094	0,085	0,054
Impedance of the fault loop (PE 2)	Z _o [mΩ/m]	0,216	0,171	0,158	0,115	0,091	0,069	0,058	0,044	0,037	0,030
Impedance of the fault loop (PE 3)	Z _o [mΩ/m]	0,247	0,200	0,187	0,137	0,110	0,089	0,071	0,054	0,046	0,037
Zero-sequence short-circuit average resistance phase - N	R _o [mΩ/m]	-	-	-	-	-	-	-	-	-	-
Zero-sequence short-circuit average reactance phase - N	X _o [mΩ/m]	-	-	-	-	-	-	-	-	-	-
Zero-sequence short-circuit average impedance phase - N	Z _o [mΩ/m]	-	-	-	-	-	-	-	-	-	-
Zero-sequence short-circuit average resistance phase - PE	R _o [mΩ/m]	0,178	0,162	0,157	0,138	0,124	0,116	0,088	0,078	0,072	0,044
Zero-sequence short-circuit average reactance phase - PE	X _o [mΩ/m]	0,031	0,023	0,023	0,021	0,020	0,019	0,015	0,009	0,008	0,007
Zero-sequence short-circuit average impedance phase - PE	Z _o [mΩ/m]	0,181	0,164	0,159	0,140	0,126	0,117	0,089	0,079	0,073	0,044
Voltage drop with distributed load ΔV [V/(m*A)]10 ⁻⁴	cosφ = 0,70	126,3	84,4	73,4	58,1	44,1	33,2	31,5	22,4	16,3	12,4
	cosφ = 0,75	133,3	88,9	77,1	60,8	45,9	34,3	32,8	23,3	17,0	12,9
	cosφ = 0,80	140,1	93,3	80,7	63,4	47,6	35,3	34,0	24,2	17,6	13,3
	cosφ = 0,85	146,6	97,5	84,1	65,9	49,2	36,1	35,1	25,1	18,1	13,6
	cosφ = 0,90	152,8	101,5	87,3	68,0	50,5	36,8	36,0	25,8	18,5	13,9
	cosφ = 0,95	158,4	104,9	90,0	69,8	51,4	37,0	36,5	26,4	18,8	14,0
	cosφ = 1,00	160,2	105,6	89,9	68,9	49,8	35,0	35,3	25,8	18,0	13,3
Weight (PE 1)	p [kg/m]	13,3	14,2	14,5	16,9	19,8	23,6	29,9	35,9	42,9	78,4
Weight (PE 2)	p [kg/m]	16,6	17,5	17,8	21,3	25,0	30,1	37,9	45,4	53,4	91,5
Weight (PE 3)	p [kg/m]	14,3	15,3	15,5	18,3	21,5	25,5	32,5	39,0	46,4	82,7
Fire load	[kWh/m]	3,4	4,1	4,1	4,5	6,4	7,9	12,0	14,3	15,8	14,8
Degree of protection	IP	55/65*	55/65*	55/65*	55/65*	55/65*	55/65*	55/65*	55/65*	55/65*	55/65*
Insulation material thermal resistance class		B/F**	B/F**	B/F**	B/F**	B/F**	B/F**	B/F**	B/F**	B/F**	B/F**
Losses for the Joule effect at nominal current	P [W/m]	220	234	311	373	442	485	765	914	1000	1154
Ambient temperature min/MAX (daily average)****	[°C]	-5/50	-5/50	-5/50	-5/50	-5/50	-5/50	-5/50	-5/50	-5/50	-5/50

* IP65 available under request for feeder lines

** Class F available under request

*** I_{cw} value at 0.5 s

**** Over 35° C it will be necessary to derate the busbar and for ambient temperatures under -5° C contact the technical support.

The data on this page refer to the 50 Hz frequency. For 60 Hz, please contact Starline.

XCP - Xtra Compact high power busbar system

Reference(s) :
see relative catalogue for detailed reference tables

C) Technical data

C.2.1 XCP-S COPPER (4 Conductors): 3P+N+PE

Rated current	I _n [A]	SINGLE BAR					DOUBLE BAR					TRIPLE BAR
		800	1000	1250	1600	2000	2500	3200	4000	5000	6300	
Overall dimension of the busbars	L x H [mm]	120 x 130	120 x 130	120 x 130	120 x 170	120 x 200	120 x 300	120 x 380	120 x 440	120 x 480	120 x 590	
Rated operational voltage	U _e [V]	1000	1000	1000	1000	1000	1000	1000	1000	1000	1000	
Rated insulation voltage	U _i [V]	1000	1000	1000	1000	1000	1000	1000	1000	1000	1000	
Frequency	f [Hz]	50/60	50/60	50/60	50/60	50/60	50/60	50/60	50/60	50/60	50/60	
Rated short-time current (1 s)	I _{CW} [kA] _{1ms}	25	36	42	42	50	65	80	100	120	150	
Peak current	I _{pk} [kA]	53	76	88	88	105	143	176	220	264	330	
Allowable specific energy for three-phase fault	I ² t [MA ² s]	625	1296	1764	1764	2500	4225	6400	10000	14400	22500	
Rated short-time current of the neutral bar (1 s)	I _{CW} [kA] _{1ms}	15	22	25	25	30	39	48	60	72	90	
Peak current of the neutral bar	I _{pk} [kA]	30	46	53	53	63	82	101	132	158	198	
Rated short-time current of the protective circuit (1 s)	I _{CW} [kA] _{1ms}	15	22	25	25	30	39	48	60	72	90	
Peak current of the protective circuit	I _{pk} [kA]	30	46	53	53	63	82	101	132	158	198	
Phase resistance at 20°C	R ₂₀ [mΩ/m]	0,077	0,058	0,045	0,034	0,024	0,021	0,017	0,012	0,008	0,0062	
Phase reactance (50Hz)	X [mΩ/m]	0,023	0,017	0,017	0,015	0,014	0,011	0,007	0,006	0,006	0,0050	
Phase impedance	Z [mΩ/m]	0,080	0,061	0,048	0,037	0,028	0,024	0,018	0,014	0,010	0,0079	
Phase resistance at thermal conditions	R [mΩ/m]	0,100	0,081	0,061	0,045	0,034	0,029	0,024	0,017	0,011	0,0085	
Phase impedance at thermal conditions	Z [mΩ/m]	0,103	0,082	0,063	0,048	0,036	0,031	0,025	0,018	0,012	0,0099	
Neutral resistance	R ₂₀ [mΩ/m]	0,077	0,058	0,045	0,034	0,024	0,021	0,017	0,012	0,008	0,0062	
Functional Earth resistance (FE)	R ₂₀ [mΩ/m]											
Functional Earth reactance (FE)	X [mΩ/m]											
Resistance of the protective bar (PE 1)	R _{PE} [mΩ/m]	0,132	0,132	0,132	0,119	0,110	0,090	0,078	0,071	0,067	0,0402	
Resistance of the protective bar (PE 2)	R _{PE} [mΩ/m]	0,049	0,049	0,049	0,038	0,032	0,025	0,021	0,017	0,016	0,0125	
Resistance of the protective bar (PE 3)	R _{PE} [mΩ/m]	0,084	0,084	0,084	0,064	0,054	0,042	0,035	0,029	0,026	0,0213	
Reactance of the protective bar	X _{PE} [mΩ/m]	0,054	0,054	0,054	0,044	0,044	0,032	0,022	0,017	0,016	0,0140	
Resistance of the fault loop (PE 1)	R _o [mΩ/m]	0,209	0,190	0,176	0,153	0,135	0,111	0,095	0,083	0,075	0,0464	
Resistance of the fault loop (PE 2)	R _o [mΩ/m]	0,126	0,108	0,094	0,072	0,056	0,046	0,038	0,029	0,023	0,0187	
Resistance of the fault loop (PE 3)	R _o [mΩ/m]	0,161	0,143	0,129	0,098	0,079	0,063	0,052	0,041	0,033	0,0275	
Reactance of the fault loop (50Hz)	X _o [mΩ/m]	0,08	0,07	0,07	0,06	0,06	0,04	0,03	0,02	0,02	0,02	
Impedance of the fault loop (PE 1)	Z _o [mΩ/m]	0,222	0,203	0,190	0,164	0,147	0,119	0,099	0,087	0,078	0,0501	
Impedance of the fault loop (PE 2)	Z _o [mΩ/m]	0,148	0,129	0,118	0,093	0,081	0,063	0,047	0,037	0,032	0,0267	
Impedance of the fault loop (PE 3)	Z _o [mΩ/m]	0,179	0,159	0,147	0,114	0,098	0,076	0,059	0,047	0,040	0,0334	
Zero-sequence short-circuit average resistance phase - N	R _o [mΩ/m]	0,103	0,078	0,060	0,045	0,033	0,028	0,023	0,016	0,010	0,0082	
Zero-sequence short-circuit average reactance phase - N	X _o [mΩ/m]	0,031	0,023	0,023	0,020	0,019	0,015	0,009	0,008	0,008	0,0067	
Zero-sequence short-circuit average impedance phase - N	Z _o [mΩ/m]	0,107	0,081	0,064	0,050	0,038	0,032	0,025	0,018	0,013	0,0106	
Zero-sequence short-circuit average resistance phase - PE	R _o [mΩ/m]	0,157	0,151	0,147	0,130	0,118	0,097	0,084	0,075	0,070	0,0423	
Zero-sequence short-circuit average reactance phase - PE	X _o [mΩ/m]	0,062	0,060	0,060	0,049	0,049	0,036	0,024	0,019	0,018	0,0157	
Zero-sequence short-circuit average impedance phase - PE	Z _o [mΩ/m]	0,169	0,163	0,158	0,139	0,128	0,103	0,087	0,078	0,072	0,0451	
Voltage drop with distributed load ΔV [V/(m*A)]10 ⁻⁴	cosφ = 0,70	75,1	59,5	47,2	36,7	29,0	24,5	19,2	14,1	10,3	8,3	
	cosφ = 0,75	78,4	62,2	49,1	37,9	29,9	25,3	19,9	14,6	10,5	8,4	
	cosφ = 0,80	81,5	64,8	50,8	39,1	30,6	25,9	20,6	15,0	10,7	8,5	
	cosφ = 0,85	84,4	67,2	52,3	40,1	31,1	26,5	21,2	15,4	10,7	8,6	
	cosφ = 0,90	86,9	69,3	53,6	40,9	31,5	26,9	21,7	15,6	10,7	8,5	
	cosφ = 0,95	88,8	71,0	54,4	41,2	31,4	27,0	22,0	15,7	10,6	8,4	
cosφ = 1,00	86,9	69,9	52,4	39,1	29,1	25,3	21,2	14,8	9,4	7,4		
Weight (PE 1)	p [kg/m]	21,2	23,8	26,9	33,5	42,5	51,0	63,0	80,9	114,9	165,1	
Weight (PE 2)	p [kg/m]	24,5	27,1	30,2	37,8	47,6	57,7	71,0	90,4	125,4	178,2	
Weight (PE 3)	p [kg/m]	22,3	24,9	28,0	34,9	44,2	53,2	65,6	84,0	118,4	169,3	
Fire load	[kWh/m]	4,5	5,5	5,5	8,0	8,2	10,5	16,0	19,0	21,0	22,0	
Degree of protection	IP	55/65*	55/65*	55/65*	55/65*	55/65*	55/65*	55/65*	55/65*	55/65*	55/65*	
Insulation material thermal resistance class		B/F**	B/F**	B/F**	B/F**	B/F**	B/F**	B/F**	B/F**	B/F**	B/F**	
Losses for the Joule effect at nominal current	P [W/m]	193	242	284	347	403	547	752	823	816	1015	
Ambient temperature min/MAX (daily average)**	[°C]	-5/50	-5/50	-5/50	-5/50	-5/50	-5/50	-5/50	-5/50	-5/50	-5/50	

* IP65 available under request for feeder lines

** Class F available under request

*** Over 35° C it will be necessary to derate the busbar and for ambient temperatures under -5° C contact the technical support.

The data on this page refer to the 50 Hz frequency. For 60 Hz, please contact Starline.

XCP - Xtra Compact high power busbar system

Reference(s) :

see relative catalogue for detailed reference tables

C) Technical data

C.2.2 XCP-S COPPER (5 Conductors - clean earth): 3P+N+PE+FE

Rated current	I _n [A]	SINGLE BAR					DOUBLE BAR					TRIPLE BAR
		800	1000	1250	1600	2000	2500	3200	4000	5000	6300	
Overall dimension of the busbars	L x H [mm]	120 x 130	120 x 130	120 x 130	120 x 170	120 x 200	120 x 300	120 x 380	120 x 440	120 x 480	120 x 590	
Rated operational voltage	U _e [V]	1000	1000	1000	1000	1000	1000	1000	1000	1000	1000	
Rated insulation voltage	U _i [V]	1000	1000	1000	1000	1000	1000	1000	1000	1000	1000	
Frequency	f [Hz]	50/60	50/60	50/60	50/60	50/60	50/60	50/60	50/60	50/60	50/60	
Rated short-time current (1 s)	I _{cw} [kA] _{rms}	25	36	42	42	50	65	80	100	120	150	
Peak current	I _{pk} [kA]	53	76	88	88	105	143	176	220	264	330	
Allowable specific energy for three-phase fault	I ² t [MA ² s]	625	1296	1764	1764	2500	4225	6400	10000	14400	22500	
Rated short-time current of the neutral bar (1 s)	I _{cn} [kA] _{rms}	15	22	25	25	30	39	48	60	72	90	
Peak current of the neutral bar	I _{pn} [kA]	30	46	53	53	63	82	101	132	158	198	
Rated short-time current of the protective circuit (1 s)	I _{cn} [kA] _{rms}	15	22	25	25	30	39	48	60	72	90	
Peak current of the protective circuit	I _{pn} [kA]	30	46	53	53	63	82	101	132	158	198	
Phase resistance at 20°C	R ₂₀ [mΩ/m]	0,077	0,058	0,045	0,034	0,024	0,021	0,017	0,012	0,008	0,0062	
Phase reactance (50Hz)	X [mΩ/m]	0,023	0,017	0,017	0,015	0,014	0,011	0,007	0,006	0,006	0,0050	
Phase impedance	Z [mΩ/m]	0,080	0,061	0,048	0,037	0,028	0,024	0,018	0,014	0,010	0,0079	
Phase resistance at thermal conditions	R [mΩ/m]	0,100	0,081	0,061	0,045	0,034	0,029	0,024	0,017	0,011	0,0085	
Phase impedance at thermal conditions	Z [mΩ/m]	0,103	0,082	0,063	0,048	0,036	0,031	0,025	0,018	0,012	0,0099	
Neutral resistance	R ₂₀ [mΩ/m]	0,077	0,058	0,045	0,034	0,024	0,021	0,017	0,012	0,008	0,0062	
Functional Earth resistance (FE)	R ₂₀ [mΩ/m]	0,077	0,058	0,045	0,034	0,024	0,021	0,017	0,012	0,008	0,0062	
Functional Earth reactance (FE)	X [mΩ/m]	0,023	0,017	0,017	0,015	0,014	0,011	0,007	0,006	0,006	0,0050	
Resistance of the protective bar (PE 1)	R _{PE} [mΩ/m]	0,133	0,133	0,133	0,120	0,111	0,090	0,079	0,072	0,068	0,0412	
Resistance of the protective bar (PE 2)	R _{PE} [mΩ/m]	0,049	0,049	0,049	0,038	0,032	0,025	0,021	0,017	0,016	0,0125	
Resistance of the protective bar (PE 3)	R _{PE} [mΩ/m]	0,084	0,084	0,084	0,064	0,054	0,042	0,035	0,029	0,026	0,0213	
Reactance of the protective bar	X _{PE} [mΩ/m]	0,054	0,054	0,054	0,044	0,044	0,032	0,022	0,017	0,016	0,0140	
Resistance of the fault loop (PE 1)	R _o [mΩ/m]	0,126	0,099	0,078	0,060	0,045	0,038	0,031	0,023	0,015	0,0115	
Resistance of the fault loop (PE 2)	R _o [mΩ/m]	0,107	0,085	0,068	0,052	0,038	0,032	0,026	0,019	0,013	0,0103	
Resistance of the fault loop (PE 3)	R _o [mΩ/m]	0,117	0,093	0,074	0,056	0,041	0,035	0,028	0,021	0,014	0,0109	
Reactance of the fault loop (50Hz)	X _o [mΩ/m]	0,077	0,071	0,071	0,059	0,058	0,043	0,029	0,023	0,022	0,0190	
Impedance of the fault loop (PE 1)	Z _o [mΩ/m]	0,147	0,122	0,106	0,084	0,073	0,058	0,042	0,032	0,026	0,0222	
Impedance of the fault loop (PE 2)	Z _o [mΩ/m]	0,132	0,111	0,098	0,079	0,070	0,054	0,039	0,030	0,025	0,0216	
Impedance of the fault loop (PE 3)	Z _o [mΩ/m]	0,140	0,117	0,102	0,081	0,071	0,056	0,041	0,031	0,026	0,0219	
Zero-sequence short-circuit average resistance phase - N	R _o [mΩ/m]	0,103	0,078	0,060	0,045	0,033	0,028	0,023	0,016	0,010	0,0082	
Zero-sequence short-circuit average reactance phase - N	X _o [mΩ/m]	0,031	0,023	0,023	0,020	0,019	0,015	0,009	0,008	0,008	0,0067	
Zero-sequence short-circuit average impedance phase - N	Z _o [mΩ/m]	0,107	0,081	0,064	0,050	0,038	0,032	0,025	0,018	0,013	0,0106	
Zero-sequence short-circuit average resistance phase - PE	R _o [mΩ/m]	0,103	0,078	0,060	0,045	0,033	0,028	0,023	0,016	0,010	0,0082	
Zero-sequence short-circuit average reactance phase - PE	X _o [mΩ/m]	0,031	0,023	0,023	0,020	0,019	0,015	0,009	0,008	0,008	0,0067	
Zero-sequence short-circuit average impedance phase - PE	Z _o [mΩ/m]	0,107	0,081	0,064	0,050	0,038	0,032	0,025	0,018	0,013	0,0106	
Voltage drop with distributed load ΔV [V/(m ² A)]10 ⁻⁴	cosφ = 0,70	75,1	59,5	47,2	36,7	29,0	24,5	19,2	14,1	10,3	8,3	
	cosφ = 0,75	78,4	62,2	49,1	37,9	29,9	25,3	19,9	14,6	10,5	8,4	
	cosφ = 0,80	81,5	64,8	50,8	39,1	30,6	25,9	20,6	15,0	10,7	8,5	
	cosφ = 0,85	84,4	67,2	52,3	40,1	31,1	26,5	21,2	15,4	10,7	8,6	
	cosφ = 0,90	86,9	69,3	53,6	40,9	31,5	26,9	21,7	15,6	10,7	8,5	
	cosφ = 0,95	88,8	71,0	54,4	41,2	31,4	27,0	22,0	15,7	10,6	8,4	
	cosφ = 1,00	86,9	69,9	52,4	39,1	29,1	25,3	21,2	14,8	9,4	7,4	
Weight (PE 1)	p [kg/m]	23,7	27,1	31,0	38,9	49,9	59,9	74,1	96,0	138,1	193,1	
Weight (PE 2)	p [kg/m]	27,1	30,4	34,4	43,3	55,1	66,5	82,1	105,5	148,6	206,2	
Weight (PE 3)	p [kg/m]	24,8	28,1	32,1	40,3	51,6	62,0	76,7	99,1	141,6	197,4	
Fire load	[kWh/m]	5,6	6,9	6,9	10,0	10,3	13,1	20,0	23,8	26,3	27,3	
Degree of protection	IP	55/65*	55/65*	55/65*	55/65*	55/65*	55/65*	55/65*	55/65*	55/65*	55/65*	
Insulation material thermal resistance class		B/F**	B/F**	B/F**	B/F**	B/F**	B/F**	B/F**	B/F**	B/F**	B/F**	
Losses for the Joule effect at nominal current	P [W/m]	193	242	284	347	403	547	752	823	816	1015	
Ambient temperature min/MAX (daily average)***	[°C]	-5/50	-5/50	-5/50	-5/50	-5/50	-5/50	-5/50	-5/50	-5/50	-5/50	

* IP65 available under request for feeder lines

** Class F available under request

*** Over 35° C it will be necessary to derate the busbar and for ambient temperatures under -5° C contact the technical support.

The data on this page refer to the 50 Hz frequency. For 60 Hz, please contact Starline.

XCP - Xtra Compact high power busbar system

Reference(s) :

see relative catalogue for detailed reference tables

C) Technical data

C.2.3 XCP-S COPPER (5 Conductors – double neutral): 3P+2N+PE

Rated current	I _n [A]	SINGLE BAR					DOUBLE BAR					TRIPLE BAR
		800	1000	1250	1600	2000	2500	3200	4000	5000	6300	
Overall dimension of the busbars	L x H [mm]	120 x 130	120 x 130	120 x 130	120 x 170	120 x 200	120 x 300	120 x 380	120 x 440	120 x 480	120 x 590	
Rated operational voltage	U _e [V]	1000	1000	1000	1000	1000	1000	1000	1000	1000	1000	
Rated insulation voltage	U _i [V]	1000	1000	1000	1000	1000	1000	1000	1000	1000	1000	
Frequency	f [Hz]	50/60	50/60	50/60	50/60	50/60	50/60	50/60	50/60	50/60	50/60	
Rated short-time current (1 s)	I _{cw} [kA] _{rms}	25	36	42	42	50	65	80	100	120	150	
Peak current	I _{pk} [kA]	53	76	88	88	105	143	176	220	264	330	
Allowable specific energy for three-phase fault	I ² t [MA ² s]	625	1296	1764	1764	2500	4225	6400	10000	14400	22500	
Rated short-time current of the neutral bar (1 s)	I _{cn} [kA] _{rms}	15	22	25	25	30	39	48	60	72	90	
Peak current of the neutral bar	I _{pk} [kA]	30	46	53	53	63	82	101	132	158	198	
Rated short-time current of the protective circuit (1 s)	I _{cp} [kA] _{rms}	15	22	25	25	30	39	48	60	72	90	
Peak current of the protective circuit	I _{pk} [kA]	30	46	53	53	63	82	101	132	158	198	
Phase resistance at 20°C	R ₂₀ [mΩ/m]	0,077	0,058	0,045	0,034	0,024	0,021	0,017	0,012	0,008	0,0062	
Phase reactance (50Hz)	X [mΩ/m]	0,023	0,017	0,017	0,015	0,014	0,011	0,007	0,006	0,006	0,0050	
Phase impedance	Z [mΩ/m]	0,080	0,061	0,048	0,037	0,028	0,024	0,018	0,014	0,010	0,0079	
Phase resistance at thermal conditions	R [mΩ/m]	0,100	0,081	0,061	0,045	0,034	0,029	0,024	0,017	0,011	0,0085	
Phase impedance at thermal conditions	Z [mΩ/m]	0,103	0,082	0,063	0,048	0,036	0,031	0,025	0,018	0,012	0,0099	
Neutral resistance	R ₂₀ [mΩ/m]	0,038	0,029	0,022	0,017	0,012	0,011	0,008	0,006	0,004	0,0031	
Functional Earth resistance (FE)	R ₂₀ [mΩ/m]	-	-	-	-	-	-	-	-	-	-	
Functional Earth reactance (FE)	X [mΩ/m]	-	-	-	-	-	-	-	-	-	-	
Resistance of the protective bar (PE 1)	R _{PE} [mΩ/m]	0,133	0,133	0,133	0,120	0,111	0,090	0,079	0,072	0,068	0,0412	
Resistance of the protective bar (PE 2)	R _{PE} [mΩ/m]	0,049	0,049	0,049	0,038	0,032	0,025	0,021	0,017	0,016	0,0125	
Resistance of the protective bar (PE 3)	R _{PE} [mΩ/m]	0,084	0,084	0,084	0,064	0,054	0,042	0,035	0,029	0,026	0,0213	
Reactance of the protective bar	X _{PE} [mΩ/m]	0,054	0,054	0,054	0,044	0,044	0,032	0,022	0,017	0,016	0,0140	
Resistance of the fault loop (PE 1)	R _o [mΩ/m]	0,210	0,192	0,178	0,154	0,135	0,111	0,096	0,084	0,076	0,0473	
Resistance of the fault loop (PE 2)	R _o [mΩ/m]	0,126	0,108	0,094	0,072	0,056	0,046	0,038	0,029	0,023	0,0187	
Resistance of the fault loop (PE 3)	R _o [mΩ/m]	0,161	0,143	0,129	0,098	0,079	0,063	0,052	0,041	0,033	0,0275	
Reactance of the fault loop (50Hz)	X _o [mΩ/m]	0,077	0,071	0,071	0,059	0,058	0,043	0,029	0,023	0,022	0,0190	
Impedance of the fault loop (PE 1)	Z _o [mΩ/m]	0,224	0,204	0,191	0,165	0,147	0,119	0,100	0,087	0,079	0,0510	
Impedance of the fault loop (PE 2)	Z _o [mΩ/m]	0,148	0,129	0,118	0,093	0,081	0,063	0,047	0,037	0,032	0,0267	
Impedance of the fault loop (PE 3)	Z _o [mΩ/m]	0,179	0,159	0,147	0,114	0,098	0,076	0,059	0,047	0,040	0,0334	
Zero-sequence short-circuit average resistance phase - N	R _o [mΩ/m]	0,064	0,049	0,037	0,028	0,020	0,018	0,014	0,010	0,006	0,0051	
Zero-sequence short-circuit average reactance phase - N	X _o [mΩ/m]	0,019	0,014	0,014	0,013	0,012	0,009	0,006	0,005	0,005	0,0042	
Zero-sequence short-circuit average impedance phase - N	Z _o [mΩ/m]	0,067	0,051	0,040	0,031	0,024	0,020	0,015	0,011	0,008	0,0066	
Zero-sequence short-circuit average resistance phase - PE	R _o [mΩ/m]	0,157	0,151	0,147	0,130	0,118	0,097	0,084	0,075	0,070	0,0423	
Zero-sequence short-circuit average reactance phase - PE	X _o [mΩ/m]	0,062	0,060	0,060	0,049	0,049	0,036	0,024	0,019	0,018	0,0157	
Zero-sequence short-circuit average impedance phase - PE	Z _o [mΩ/m]	0,169	0,163	0,158	0,139	0,128	0,103	0,087	0,078	0,072	0,0451	
Voltage drop with distributed load ΔV [V/(m*A)]10 ⁻⁶	cosφ = 0,70	75,1	59,5	47,2	36,7	29,0	24,5	19,2	14,1	10,3	8,3	
	cosφ = 0,75	78,4	62,2	49,1	37,9	29,9	25,3	19,9	14,6	10,5	8,4	
	cosφ = 0,80	81,5	64,8	50,8	39,1	30,6	25,9	20,6	15,0	10,7	8,5	
	cosφ = 0,85	84,4	67,2	52,3	40,1	31,1	26,5	21,2	15,4	10,7	8,6	
	cosφ = 0,90	86,9	69,3	53,6	40,9	31,5	26,9	21,7	15,6	10,7	8,5	
	cosφ = 0,95	88,8	71,0	54,4	41,2	31,4	27,0	22,0	15,7	10,6	8,4	
cosφ = 1,00	86,9	69,9	52,4	39,1	29,1	25,3	21,2	14,8	9,4	7,4		
Weight (PE 1)	p [kg/m]	23,7	27,1	31,0	38,9	49,9	59,9	74,1	96,0	138,1	193,1	
Weight (PE 2)	p [kg/m]	27,1	30,4	34,4	43,3	55,1	66,5	82,1	105,5	148,6	206,2	
Weight (PE 3)	p [kg/m]	24,8	28,1	32,1	40,3	51,6	62,0	76,7	99,1	141,6	197,4	
Fire load	[kWh/m]	5,6	6,9	6,9	10,0	10,3	13,1	20,0	23,8	26,3	27,3	
Degree of protection	IP	55/65*	55/65*	55/65*	55/65*	55/65*	55/65*	55/65*	55/65*	55/65*	55/65*	
Insulation material thermal resistance class		B/F**	B/F**	B/F**	B/F**	B/F**	B/F**	B/F**	B/F**	B/F**	B/F**	
Losses for the Joule effect at nominal current	P [W/m]	193	242	284	347	403	547	752	823	816	1015	
Ambient temperature min/MAX (daily average)***	[°C]	-5/50	-5/50	-5/50	-5/50	-5/50	-5/50	-5/50	-5/50	-5/50	-5/50	

* IP65 available under request for feeder lines

** Class F available under request

*** Over 35° C it will be necessary to derate the busbar and for ambient temperatures under -5° C contact the technical support.

The data on this page refer to the 50 Hz frequency. For 60 Hz, please contact Starline.

XCP - Xtra Compact high power busbar system

Reference(s) :

see relative catalogue for detailed reference tables

C) Technical data

C.2.4 XCP-S COPPER (3 Conductors):3P+PE

Rated current	I _n [A]	SINGLE BAR					DOUBLE BAR					TRIPLE BAR
		800	1000	1250	1600	2000	2500	3200	4000	5000	6300	
Overall dimension of the busbars	L x H [mm]	120 x 130	120 x 130	120 x 130	120 x 170	120 x 200	120 x 300	120 x 380	120 x 440	120 x 480	120 x 590	
Rated operational voltage	U _e [V]	1000	1000	1000	1000	1000	1000	1000	1000	1000	1000	
Rated insulation voltage	U _i [V]	1000	1000	1000	1000	1000	1000	1000	1000	1000	1000	
Frequency	f [Hz]	50/60	50/60	50/60	50/60	50/60	50/60	50/60	50/60	50/60	50/60	
Rated short-time current (1 s)	I _{cw} [kA] _{rms}	25	36	42	42	50	65	80	100	120	150	
Peak current	I _{pk} [kA]	53	76	88	88	105	143	176	220	264	330	
Allowable specific energy for three-phase fault	I ² t [MA ² s]	625	1296	1764	1764	2500	4225	6400	10000	14400	22500	
Rated short-time current of the neutral bar (1 s)	I _{cn} [kA] _{rms}	-	-	-	-	-	-	-	-	-	-	
Peak current of the neutral bar	I _{pk} [kA]	-	-	-	-	-	-	-	-	-	-	
Rated short-time current of the protective circuit (1 s)	I _{cn} [kA] _{rms}	15	22	25	25	30	39	48	60	72	90	
Peak current of the protective circuit	I _{pk} [kA]	30	46	53	53	63	82	101	132	158	198	
Phase resistance at 20°C	R ₂₀ [mΩ/m]	0,077	0,058	0,045	0,034	0,024	0,021	0,017	0,012	0,008	0,0062	
Phase reactance (50Hz)	X [mΩ/m]	0,023	0,017	0,017	0,015	0,014	0,011	0,007	0,006	0,006	0,0050	
Phase impedance	Z [mΩ/m]	0,080	0,061	0,048	0,037	0,028	0,024	0,018	0,014	0,010	0,0079	
Phase resistance at thermal conditions	R [mΩ/m]	0,100	0,081	0,061	0,045	0,034	0,029	0,024	0,017	0,011	0,0085	
Phase impedance at thermal conditions	Z [mΩ/m]	0,103	0,082	0,063	0,048	0,036	0,031	0,025	0,018	0,012	0,0099	
Neutral resistance	R ₂₀ [mΩ/m]	-	-	-	-	-	-	-	-	-	-	
Functional Earth resistance (FE)	R ₂₀ [mΩ/m]	-	-	-	-	-	-	-	-	-	-	
Functional Earth reactance (FE)	X [mΩ/m]	-	-	-	-	-	-	-	-	-	-	
Resistance of the protective bar (PE 1)	R _{PE} [mΩ/m]	0,130	0,130	0,130	0,118	0,110	0,089	0,078	0,071	0,067	0,0396	
Resistance of the protective bar (PE 2)	R _{PE} [mΩ/m]	0,049	0,049	0,049	0,038	0,032	0,025	0,021	0,017	0,016	0,0125	
Resistance of the protective bar (PE 3)	R _{PE} [mΩ/m]	0,084	0,084	0,084	0,064	0,054	0,042	0,035	0,029	0,026	0,0213	
Reactance of the protective bar	X _{PE} [mΩ/m]	0,054	0,054	0,054	0,044	0,044	0,032	0,022	0,017	0,016	0,0140	
Resistance of the fault loop (PE 1)	R ₀ [mΩ/m]	0,206	0,188	0,174	0,152	0,134	0,110	0,095	0,083	0,075	0,0458	
Resistance of the fault loop (PE 2)	R ₀ [mΩ/m]	0,126	0,108	0,094	0,072	0,056	0,046	0,038	0,029	0,023	0,0187	
Resistance of the fault loop (PE 3)	R ₀ [mΩ/m]	0,161	0,143	0,129	0,098	0,079	0,063	0,052	0,041	0,033	0,0275	
Reactance of the fault loop (50Hz)	X ₀ [mΩ/m]	0,077	0,071	0,071	0,059	0,058	0,043	0,029	0,023	0,022	0,0190	
Impedance of the fault loop (PE 1)	Z ₀ [mΩ/m]	0,220	0,201	0,188	0,163	0,146	0,118	0,099	0,086	0,078	0,0496	
Impedance of the fault loop (PE 2)	Z ₀ [mΩ/m]	0,148	0,129	0,118	0,093	0,081	0,063	0,047	0,037	0,032	0,0267	
Impedance of the fault loop (PE 3)	Z ₀ [mΩ/m]	0,179	0,159	0,147	0,114	0,098	0,076	0,059	0,047	0,040	0,0334	
Zero-sequence short-circuit average resistance phase - N	R ₀ [mΩ/m]											
Zero-sequence short-circuit average reactance phase - N	X ₀ [mΩ/m]											
Zero-sequence short-circuit average impedance phase - N	Z ₀ [mΩ/m]											
Zero-sequence short-circuit average resistance phase - PE	R ₀ [mΩ/m]	0,157	0,151	0,147	0,130	0,118	0,097	0,084	0,075	0,070	0,0423	
Zero-sequence short-circuit average reactance phase - PE	X ₀ [mΩ/m]	0,062	0,060	0,060	0,049	0,049	0,036	0,024	0,019	0,018	0,0157	
Zero-sequence short-circuit average impedance phase - PE	Z ₀ [mΩ/m]	0,169	0,163	0,158	0,139	0,128	0,103	0,087	0,078	0,072	0,0451	
Voltage drop with distributed load ΔV [V/(m*A)]10 ⁻⁶	cosφ = 0,70	75,1	59,5	47,2	36,7	29,0	24,5	19,2	14,1	10,3	8,3	
	cosφ = 0,75	78,4	62,2	49,1	37,9	29,9	25,3	19,9	14,6	10,5	8,4	
	cosφ = 0,80	81,5	64,8	50,8	39,1	30,6	25,9	20,6	15,0	10,7	8,5	
	cosφ = 0,85	84,4	67,2	52,3	40,1	31,1	26,5	21,2	15,4	10,7	8,6	
	cosφ = 0,90	86,9	69,3	53,6	40,9	31,5	26,9	21,7	15,6	10,7	8,5	
	cosφ = 0,95	88,8	71,0	54,4	41,2	31,4	27,0	22,0	15,7	10,6	8,4	
cosφ = 1,00	86,9	69,9	52,4	39,1	29,1	25,3	21,2	14,8	9,4	7,4		
Weight (PE 1)	p [kg/m]	18,7	20,6	22,9	28,0	35,0	42,2	51,9	65,8	91,6	136,8	
Weight (PE 2)	p [kg/m]	22,0	23,9	26,2	32,4	40,2	48,8	59,9	75,3	102,1	149,9	
Weight (PE 3)	p [kg/m]	19,7	21,7	23,9	29,5	36,7	44,4	54,5	68,9	95,1	141,0	
Fire load	[kWh/m]	3,4	4,1	4,1	6,0	6,2	7,9	12,0	14,3	15,8	16,8	
Degree of protection	IP	55/65*	55/65*	55/65*	55/65*	55/65*	55/65*	55/65*	55/65*	55/65*	55/65*	
Insulation material thermal resistance class		B/F**	B/F**	B/F**	B/F**	B/F**	B/F**	B/F**	B/F**	B/F**	B/F**	
Losses for the Joule effect at nominal current	P [W/m]	193	242	284	347	403	547	752	823	816	1015	
Ambient temperature min/MAX (daily average)***	[°C]	-5/50	-5/50	-5/50	-5/50	-5/50	-5/50	-5/50	-5/50	-5/50	-5/50	

* IP65 available under request for feeder lines

** Class F available under request

*** Over 35° C it will be necessary to derate the busbar and for ambient temperatures under -5° C contact the technical support.

The data on this page refer to the 50 Hz frequency. For 60 Hz, please contact Starline.

XCP - Xtra Compact high power busbar system

Reference(s) :

see relative catalogue for detailed reference tables

C) Technical data

C.3.1 XCP-HP ALUMINIUM (4 Conductors):3P+N+PE

Rated current	I _n [A]	SINGLE BAR						DOUBLE BAR			TRIPLE BAR
		630	800	1000	1250	1600	2000	2500	3200	4000	5000
Overall dimension of the busbars	L x H [mm]	125 x 130	125 x 130	125 x 130	125 x 130	125 x 200	125 x 220	125 x 380	125 x 440	125 x 480	125 x 740
Rated operational voltage	U _e [V]	1000	1000	1000	1000	1000	1000	1000	1000	1000	1000
Rated insulation voltage	U _i [V]	1000	1000	1000	1000	1000	1000	1000	1000	1000	1000
Frequency	f [Hz]	50/60	50/60	50/60	50/60	50/60	50/60	50/60	50/60	50/60	50/60
Rated short-time current (1 s)	I _{scw} [kA] _{max}	36	36	50	70	70	85	120	120	150	150
Peak current	I _{pk} [kA]	76	76	105	154	154	187	264	264	330	330
Allowable specific energy for three-phase fault	I ² t [MA ² s]	1296	1296	2500	4900	4900	7225	14400	14400	22500	22500
Rated short-time current of the neutral bar (1 s)	I _{scw} [kA] _{max}	22	22	30	42	42	51	72	72	90	90
Peak current of the neutral bar	I _{pk} [kA]	45	45	63	88	88	112	158	158	198	198
Rated short-time current of the protective circuit (1 s)	I _{scw} [kA] _{max}	22	22	30	42	42	51	72	72	90	90
Peak current of the protective circuit	I _{pk} [kA]	45	45	63	88	88	112	158	158	198	198
Phase resistance at 20°C	R ₂₀ [mΩ/m]	0,077	0,077	0,056	0,045	0,031	0,025	0,022	0,015	0,012	0,010
Phase reactance (50Hz)	X [mΩ/m]	0,023	0,017	0,017	0,015	0,014	0,011	0,006	0,006	0,006	0,005
Phase impedance	Z [mΩ/m]	0,080	0,079	0,059	0,047	0,034	0,027	0,023	0,017	0,014	0,011
Phase resistance at thermal conditions	R [mΩ/m]	0,101	0,102	0,076	0,062	0,043	0,035	0,032	0,022	0,018	0,014
Phase impedance at thermal conditions	Z [mΩ/m]	0,104	0,103	0,078	0,064	0,045	0,037	0,032	0,023	0,019	0,015
Neutral resistance	R ₂₀ [mΩ/m]	0,077	0,077	0,056	0,045	0,031	0,025	0,022	0,015	0,012	0,010
Functional Earth resistance (FE)	R ₂₀ [mΩ/m]	-	-	-	-	-	-	-	-	-	-
Functional Earth reactance (FE)	X [mΩ/m]	-	-	-	-	-	-	-	-	-	-
Resistance of the protective bar (PE 1)	R _{PE} [mΩ/m]	0,132	0,132	0,132	0,133	0,111	0,106	0,078	0,072	0,068	0,035
Resistance of the protective bar (PE 2)	R _{PE} [mΩ/m]	0,049	0,049	0,049	0,049	0,032	0,029	0,019	0,016	0,014	0,010
Resistance of the protective bar (PE 3)	R _{PE} [mΩ/m]	0,084	0,084	0,084	0,084	0,054	0,049	0,032	0,027	0,025	0,016
Reactance of the protective bar	X _{PE} [mΩ/m]	0,080	0,078	0,078	0,048	0,039	0,028	0,020	0,015	0,016	0,014
Resistance of the fault loop (PE 1)	R ₀ [mΩ/m]	0,208	0,208	0,188	0,178	0,142	0,131	0,101	0,087	0,080	0,045
Resistance of the fault loop (PE 2)	R ₀ [mΩ/m]	0,126	0,126	0,106	0,094	0,063	0,054	0,041	0,031	0,027	0,019
Resistance of the fault loop (PE 3)	R ₀ [mΩ/m]	0,161	0,161	0,140	0,129	0,085	0,074	0,054	0,043	0,037	0,026
Reactance of the fault loop (50Hz)	X ₀ [mΩ/m]	0,10	0,10	0,10	0,06	0,05	0,04	0,03	0,02	0,02	0,02
Impedance of the fault loop (PE 1)	Z ₀ [mΩ/m]	0,232	0,229	0,210	0,189	0,151	0,137	0,104	0,089	0,083	0,049
Impedance of the fault loop (PE 2)	Z ₀ [mΩ/m]	0,163	0,158	0,142	0,114	0,082	0,067	0,049	0,038	0,035	0,027
Impedance of the fault loop (PE 3)	Z ₀ [mΩ/m]	0,191	0,187	0,169	0,144	0,100	0,084	0,060	0,047	0,043	0,032
Zero-sequence short-circuit average resistance phase - N	R ₀ [mΩ/m]	0,102	0,102	0,075	0,060	0,041	0,033	0,030	0,021	0,017	0,013
Zero-sequence short-circuit average reactance phase - N	X ₀ [mΩ/m]	0,031	0,023	0,023	0,020	0,019	0,015	0,008	0,008	0,008	0,007
Zero-sequence short-circuit average impedance phase - N	Z ₀ [mΩ/m]	0,107	0,105	0,078	0,063	0,045	0,036	0,031	0,022	0,018	0,014
Zero-sequence short-circuit average resistance phase - PE	R ₀ [mΩ/m]	0,157	0,157	0,150	0,148	0,121	0,115	0,086	0,077	0,072	0,039
Zero-sequence short-circuit average reactance phase - PE	X ₀ [mΩ/m]	0,088	0,084	0,084	0,053	0,044	0,032	0,022	0,017	0,018	0,016
Zero-sequence short-circuit average impedance phase - PE	Z ₀ [mΩ/m]	0,180	0,178	0,172	0,157	0,129	0,119	0,088	0,079	0,074	0,042
Voltage drop with distributed load ΔV [V/(m ² A)]10 ⁻²	cosφ = 0,70	75,6	72,1	56,5	47,0	34,7	27,9	23,0	17,2	14,6	11,5
	cosφ = 0,75	79,0	75,7	59,0	49,0	36,0	28,9	24,1	17,9	15,1	11,9
	cosφ = 0,80	82,1	79,2	61,3	50,9	37,1	29,9	25,1	18,5	15,6	12,2
	cosφ = 0,85	85,1	82,6	63,5	52,7	38,1	30,7	26,1	19,1	16,0	12,5
	cosφ = 0,90	87,7	85,6	65,5	54,2	38,8	31,3	27,0	19,6	16,3	12,7
	cosφ = 0,95	89,6	88,2	66,9	55,3	39,2	31,7	27,8	19,9	16,4	12,8
	cosφ = 1,00	87,7	88,0	65,6	53,9	37,3	30,2	27,5	19,3	15,6	12,0
Weight (PE 1)	ρ [kg/m]	16,0	16,0	17,8	19,3	25,4	29,4	37,7	47,3	54,3	91,0
Weight (PE 2)	ρ [kg/m]	19,3	19,3	21,1	22,6	30,5	35,0	46,4	57,6	65,7	108,0
Weight (PE 3)	ρ [kg/m]	17,1	17,1	18,9	20,3	27,1	31,2	40,5	50,7	58,0	96,5
Fire load	[kWh/m]	4,5	5,5	5,5	6,0	8,5	10,5	16,0	19,0	21,0	21,0
Degree of protection	IP	55/65*	55/65*	55/65*	55/65*	55/65*	55/65*	55/65*	55/65*	55/65*	55/65*
Insulation material thermal resistance class	B/F**	B/F**	B/F**	B/F**	B/F**	B/F**	B/F**	B/F**	B/F**	B/F**	B/F**
Losses for the Joule effect at nominal current	P [W/m]	121	195	227	292	330	418	596	683	863	1042
Ambient temperature min/MAX (daily average)***	[°C]	-5/70	-5/70	-5/70	-5/70	-5/70	-5/70	-5/70	-5/70	-5/70	-5/70

* IP65 available under request for feeder lines

** Class F available under request

*** Over 50° C it will be necessary to derate the busbar and for ambient temperatures under -5° C contact the technical support.

The data on this page refer to the 50 Hz frequency. For 60 Hz, please contact Starline.

XCP - Xtra Compact high power busbar system

Reference(s) :

see relative catalogue for detailed reference tables

C) Technical data

C.3.2 XCP-HP ALUMINIUM (5 Conductors - clean earth): 3P+N+PE+FE

Rated current	I _n [A]	SINGLE BAR						DOUBLE BAR			TRIPLE BAR
		630	800	1000	1250	1600	2000	2500	3200	4000	5000
Overall dimension of the busbars	L x H [mm]	125 x 130	125 x 130	125 x 130	125 x 130	125 x 200	125 x 220	125 x 380	125 x 440	125 x 480	125 x 740
Rated operational voltage	U ₀ [V]	1000	1000	1000	1000	1000	1000	1000	1000	1000	1000
Rated insulation voltage	U _i [V]	1000	1000	1000	1000	1000	1000	1000	1000	1000	1000
Frequency	f [Hz]	50/60	50/60	50/60	50/60	50/60	50/60	50/60	50/60	50/60	50/60
Rated short-time current (1 s)	I _{cw} [kA] _{max}	36	36	50	70	70	85	120	120	150	150
Peak current	I _{pk} [kA]	76	76	105	154	154	187	264	264	330	330
Allowable specific energy for three-phase fault	I ² t [MA ² s]	1296	1296	2500	4900	4900	7225	14400	14400	22500	22500
Rated short-time current of the neutral bar (1 s)	I _{cn} [kA] _{max}	22	22	30	42	42	51	72	72	90	90
Peak current of the neutral bar	I _{pn} [kA]	45	45	63	88	88	112	158	158	198	198
Rated short-time current of the protective circuit (1 s)	I _{cp} [kA] _{max}	22	22	30	42	42	51	72	72	90	90
Peak current of the protective circuit	I _{pp} [kA]	45	45	63	88	88	112	158	158	198	198
Phase resistance at 20°C	R ₃₀ [mΩ/m]	0,077	0,077	0,056	0,045	0,031	0,025	0,022	0,015	0,012	0,010
Phase reactance (50Hz)	X [mΩ/m]	0,023	0,017	0,017	0,015	0,014	0,011	0,006	0,006	0,006	0,005
Phase impedance	Z [mΩ/m]	0,080	0,079	0,059	0,047	0,034	0,027	0,023	0,017	0,014	0,011
Phase resistance at thermal conditions	R [mΩ/m]	0,101	0,102	0,076	0,062	0,043	0,035	0,032	0,022	0,018	0,014
Phase impedance at thermal conditions	Z [mΩ/m]	0,104	0,103	0,078	0,064	0,045	0,037	0,032	0,023	0,019	0,015
Neutral resistance	R ₃₀ [mΩ/m]	0,077	0,077	0,056	0,045	0,031	0,025	0,022	0,015	0,012	0,010
Functional Earth resistance (FE)	R ₃₀ [mΩ/m]	0,077	0,077	0,056	0,045	0,031	0,025	0,022	0,015	0,012	0,010
Functional Earth reactance (FE)	X [mΩ/m]	0,023	0,017	0,017	0,015	0,014	0,011	0,006	0,006	0,006	0,005
Resistance of the protective bar (PE 1)	R _{pe} [mΩ/m]	0,133	0,133	0,266	0,266	0,222	0,213	0,156	0,143	0,136	0,035
Resistance of the protective bar (PE 2)	R _{pe} [mΩ/m]	0,049	0,049	0,049	0,049	0,032	0,029	0,019	0,016	0,014	0,010
Resistance of the protective bar (PE 3)	R _{pe} [mΩ/m]	0,084	0,084	0,084	0,084	0,054	0,049	0,032	0,027	0,025	0,016
Reactance of the protective bar	X _{pe} [mΩ/m]	0,080	0,078	0,078	0,048	0,039	0,028	0,020	0,015	0,016	0,014
Resistance of the fault loop (PE 1)	R _{fa} [mΩ/m]	0,125	0,125	0,102	0,083	0,058	0,047	0,042	0,029	0,024	0,017
Resistance of the fault loop (PE 2)	R _{fa} [mΩ/m]	0,107	0,107	0,082	0,069	0,047	0,038	0,033	0,023	0,019	0,014
Resistance of the fault loop (PE 3)	R _{fa} [mΩ/m]	0,117	0,117	0,090	0,074	0,051	0,042	0,036	0,025	0,021	0,016
Reactance of the fault loop (50Hz)	X _{fa} [mΩ/m]	0,10	0,10	0,10	0,06	0,05	0,04	0,03	0,02	0,02	0,02
Impedance of the fault loop (PE 1)	Z _{fa} [mΩ/m]	0,162	0,157	0,140	0,105	0,079	0,061	0,049	0,036	0,032	0,026
Impedance of the fault loop (PE 2)	Z _{fa} [mΩ/m]	0,148	0,143	0,126	0,093	0,071	0,055	0,042	0,031	0,029	0,024
Impedance of the fault loop (PE 3)	Z _{fa} [mΩ/m]	0,156	0,151	0,131	0,097	0,073	0,057	0,044	0,033	0,030	0,025
Zero-sequence short-circuit average resistance phase - N	R ₀ [mΩ/m]	0,102	0,102	0,075	0,060	0,041	0,033	0,030	0,021	0,017	0,013
Zero-sequence short-circuit average reactance phase - N	X ₀ [mΩ/m]	0,031	0,023	0,023	0,020	0,019	0,015	0,008	0,008	0,008	0,007
Zero-sequence short-circuit average impedance phase - N	Z ₀ [mΩ/m]	0,107	0,105	0,078	0,063	0,045	0,036	0,031	0,022	0,018	0,014
Zero-sequence short-circuit average resistance phase - PE	R ₀ [mΩ/m]	0,102	0,102	0,075	0,060	0,041	0,033	0,030	0,021	0,017	0,013
Zero-sequence short-circuit average reactance phase - PE	X ₀ [mΩ/m]	0,031	0,023	0,023	0,020	0,019	0,015	0,008	0,008	0,008	0,007
Zero-sequence short-circuit average impedance phase - PE	Z ₀ [mΩ/m]	0,107	0,105	0,078	0,063	0,045	0,036	0,031	0,022	0,018	0,014
Voltage drop with distributed load ΔV [V/(m*A)]10 ⁻⁶	cosφ = 0,70	75,6	72,1	56,5	47,0	34,7	27,9	23,0	17,2	14,6	11,5
	cosφ = 0,75	79,0	75,7	59,0	49,0	36,0	28,9	24,1	17,9	15,1	11,9
	cosφ = 0,80	82,1	79,2	61,3	50,9	37,1	29,9	25,1	18,5	15,6	12,2
	cosφ = 0,85	85,1	82,6	63,5	52,7	38,1	30,7	26,1	19,1	16,0	12,5
	cosφ = 0,90	87,7	85,6	65,5	54,2	38,8	31,3	27,0	19,6	16,3	12,7
	cosφ = 0,95	89,6	88,2	66,9	55,3	39,2	31,7	27,8	19,9	16,4	12,8
cosφ = 1,00	87,7	88,0	65,6	53,9	37,3	30,2	27,5	19,3	15,6	12,0	
Weight (PE 1)	p [kg/m]	17,5	17,5	19,7	21,7	28,8	33,6	42,8	54,4	62,9	102,2
Weight (PE 2)	p [kg/m]	20,8	20,8	23,0	25,0	34,0	39,3	51,5	64,7	74,2	119,2
Weight (PE 3)	p [kg/m]	21,0	18,6	20,8	22,7	30,5	35,5	45,6	57,7	66,6	107,8
Fire load	[kWh/m]	5,6	6,9	6,9	7,5	10,6	13,1	20,0	23,8	26,3	27,3
Degree of protection	IP	55/65*	55/65*	55/65*	55/65*	55/65*	55/65*	55/65*	55/65*	55/65*	55/65*
Insulation material thermal resistance class	B/F**	B/F**	B/F**	B/F**	B/F**	B/F**	B/F**	B/F**	B/F**	B/F**	B/F**
Losses for the Joule effect at nominal current	P [W/m]	121	195	227	292	330	418	596	683	863	1042
Ambient temperature min/MAX (daily average)***	[°C]	-5/70	-5/70	-5/70	-5/70	-5/70	-5/70	-5/70	-5/70	-5/70	-5/70

* IP65 available under request for feeder lines

** Class F available under request

*** Over 50° C it will be necessary to derate the busbar and for ambient temperatures under -5° C contact the technical support.

The data on this page refer to the 50 Hz frequency. For 60 Hz, please contact Starline.

XCP - Xtra Compact high power busbar system

Reference(s) :

see relative catalogue for detailed reference tables

C) Technical data

C.3.3 XCP-HP ALUMINIUM (5 Conductors – double neutral): 3P+2N+PE

Rated current	I _n [A]	SINGLE BAR						DOUBLE BAR			TRIPLE BAR
		630	800	1000	1250	1600	2000	2500	3200	4000	5000
Overall dimension of the busbars	L x H [mm]	125 x 130	125 x 130	125 x 130	125 x 130	125 x 200	125 x 220	125 x 380	125 x 440	125 x 480	125 x 740
Rated operational voltage	U _e [V]	1000	1000	1000	1000	1000	1000	1000	1000	1000	1000
Rated insulation voltage	U _i [V]	1000	1000	1000	1000	1000	1000	1000	1000	1000	1000
Frequency	f [Hz]	50/60	50/60	50/60	50/60	50/60	50/60	50/60	50/60	50/60	50/60
Rated short-time current (1 s)	I _{cw} [kA] _{max}	36	36	50	70	70	85	120	120	150	150
Peak current	I _{pk} [kA]	76	76	105	154	154	187	264	264	330	330
Allowable specific energy for three-phase fault	I ² t [MA ² s]	1296	1296	2500	4900	4900	7225	14400	14400	22500	22500
Rated short-time current of the neutral bar (1 s)	I _{cn} [kA] _{max}	22	22	30	42	42	51	72	72	90	90
Peak current of the neutral bar	I _{pn} [kA]	45	45	63	88	88	112	158	158	198	198
Rated short-time current of the protective circuit (1 s)	I _{cp} [kA] _{max}	22	22	30	42	42	51	72	72	90	90
Peak current of the protective circuit	I _{pk} [kA]	45	45	63	88	88	112	158	158	198	198
Phase resistance at 20°C	R ₂₀ [mΩ/m]	0,077	0,077	0,056	0,045	0,031	0,025	0,022	0,015	0,012	0,010
Phase reactance (50Hz)	X [mΩ/m]	0,023	0,017	0,017	0,015	0,014	0,011	0,006	0,006	0,006	0,005
Phase impedance	Z [mΩ/m]	0,080	0,079	0,059	0,047	0,034	0,027	0,023	0,017	0,014	0,011
Phase resistance at thermal conditions	R [mΩ/m]	0,101	0,102	0,076	0,062	0,043	0,035	0,032	0,022	0,018	0,014
Phase impedance at thermal conditions	Z [mΩ/m]	0,104	0,103	0,078	0,064	0,045	0,037	0,032	0,023	0,019	0,015
Neutral resistance	R ₂₀ [mΩ/m]	0,038	0,038	0,028	0,022	0,015	0,012	0,011	0,008	0,006	0,005
Functional Earth resistance (FE)	R ₂₀ [mΩ/m]	-	-	-	-	-	-	-	-	-	-
Functional Earth reactance (FE)	X [mΩ/m]	-	-	-	-	-	-	-	-	-	-
Resistance of the protective bar (PE 1)	R _{pe} [mΩ/m]	0,133	0,133	0,266	0,266	0,222	0,213	0,156	0,143	0,136	0,035
Resistance of the protective bar (PE 2)	R _{pe} [mΩ/m]	0,049	0,049	0,049	0,049	0,032	0,029	0,019	0,016	0,014	0,010
Resistance of the protective bar (PE 3)	R _{pe} [mΩ/m]	0,084	0,084	0,084	0,084	0,054	0,049	0,032	0,027	0,025	0,016
Reactance of the protective bar	X _{pe} [mΩ/m]	0,080	0,078	0,078	0,048	0,039	0,028	0,020	0,015	0,016	0,014
Resistance of the fault loop (PE 1)	R _o [mΩ/m]	0,210	0,210	0,322	0,311	0,253	0,238	0,179	0,158	0,148	0,045
Resistance of the fault loop (PE 2)	R _o [mΩ/m]	0,126	0,126	0,106	0,094	0,063	0,054	0,041	0,031	0,027	0,019
Resistance of the fault loop (PE 3)	R _o [mΩ/m]	0,161	0,161	0,140	0,129	0,085	0,074	0,054	0,043	0,037	0,026
Reactance of the fault loop (50Hz)	X _o [mΩ/m]	0,10	0,10	0,10	0,06	0,05	0,04	0,03	0,02	0,02	0,02
Impedance of the fault loop (PE 1)	Z _o [mΩ/m]	0,234	0,230	0,336	0,318	0,258	0,241	0,181	0,160	0,150	0,049
Impedance of the fault loop (PE 2)	Z _o [mΩ/m]	0,163	0,158	0,142	0,114	0,082	0,067	0,049	0,038	0,035	0,027
Impedance of the fault loop (PE 3)	Z _o [mΩ/m]	0,191	0,187	0,169	0,144	0,100	0,084	0,060	0,047	0,043	0,032
Zero-sequence short-circuit average resistance phase - N	R _o [mΩ/m]	0,064	0,064	0,047	0,037	0,026	0,021	0,019	0,013	0,010	0,008
Zero-sequence short-circuit average reactance phase - N	X _o [mΩ/m]	0,019	0,014	0,014	0,013	0,012	0,009	0,005	0,005	0,005	0,004
Zero-sequence short-circuit average impedance phase - N	Z _o [mΩ/m]	0,247	0,225	0,225	0,212	0,206	0,228	0,159	0,177	0,114	0,114
Zero-sequence short-circuit average resistance phase - PE	R _o [mΩ/m]	0,157	0,157	0,150	0,148	0,121	0,115	0,086	0,077	0,072	0,039
Zero-sequence short-circuit average reactance phase - PE	X _o [mΩ/m]	0,088	0,084	0,084	0,053	0,044	0,032	0,022	0,017	0,018	0,016
Zero-sequence short-circuit average impedance phase - PE	Z _o [mΩ/m]	0,180	0,178	0,172	0,157	0,129	0,119	0,088	0,079	0,074	0,042
Voltage drop with distributed load ΔV [V/(m*A)]10 ⁻⁶	cosφ = 0,70	75,6	72,1	56,5	47,0	34,7	27,9	23,0	17,2	14,6	11,5
	cosφ = 0,75	79,0	75,7	59,0	49,0	36,0	28,9	24,1	17,9	15,1	11,9
	cosφ = 0,80	82,1	79,2	61,3	50,9	37,1	29,9	25,1	18,5	15,6	12,2
	cosφ = 0,85	85,1	82,6	63,5	52,7	38,1	30,7	26,1	19,1	16,0	12,5
	cosφ = 0,90	87,7	85,6	65,5	54,2	38,8	31,3	27,0	19,6	16,3	12,7
	cosφ = 0,95	89,6	88,2	66,9	55,3	39,2	31,7	27,8	19,9	16,4	12,8
cosφ = 1,00	87,7	88,0	65,6	53,9	37,3	30,2	27,5	19,3	15,6	12,0	
Weight (PE 1)	p [kg/m]	17,5	17,5	19,7	21,7	28,8	33,6	42,8	54,4	62,9	102,2
Weight (PE 2)	p [kg/m]	20,8	20,8	23,0	25,0	34,0	39,3	51,5	64,7	74,2	119,2
Weight (PE 3)	p [kg/m]	21,0	18,6	20,8	22,7	30,5	35,5	45,6	57,7	66,6	107,8
Fire load	[kWh/m]	5,6	6,9	6,9	7,5	10,6	13,1	20,0	23,8	26,3	27,3
Degree of protection	IP	55/65*	55/65*	55/65*	55/65*	55/65*	55/65*	55/65*	55/65*	55/65*	55/65*
Insulation material thermal resistance class	B/F**	B/F**	B/F**	B/F**	B/F**	B/F**	B/F**	B/F**	B/F**	B/F**	B/F**
Losses for the Joule effect at nominal current	P [W/m]	121	195	227	292	330	418	596	683	863	1042
Ambient temperature min/MAX (daily average)***	[°C]	-5/70	-5/70	-5/70	-5/70	-5/70	-5/70	-5/70	-5/70	-5/70	-5/70

* IP65 available under request for feeder lines

** Class F available under request

*** Over 50° C it will be necessary to derate the busbar and for ambient temperatures under -5° C contact the technical support.

The data on this page refer to the 50 Hz frequency. For 60 Hz, please contact Starline

XCP - Xtra Compact high power busbar system

Reference(s) :

see relative catalogue for detailed reference tables

C) Technical data

C.3.4 XCP-HP ALUMINIUM (3 Conductors) : 3P+PE

Rated current	I _n [A]	SINGLE BAR						DOUBLE BAR			TRIPLE BAR
		630	800	1000	1250	1600	2000	2500	3200	4000	5000
Overall dimension of the busbars	L x H [mm]	125 x 130	125 x 130	125 x 130	125 x 130	125 x 200	125 x 220	125 x 380	125 x 440	125 x 480	125 x 740
Rated operational voltage	U _e [V]	1000	1000	1000	1000	1000	1000	1000	1000	1000	1000
Rated insulation voltage	U _i [V]	1000	1000	1000	1000	1000	1000	1000	1000	1000	1000
Frequency	f [Hz]	50/60	50/60	50/60	50/60	50/60	50/60	50/60	50/60	50/60	50/60
Rated short-time current (1 s)	I _{cw} [kA] _{max}	36	36	50	70	70	85	120	120	150	150
Peak current	I _{pk} [kA]	76	76	105	154	154	187	264	264	330	330
Allowable specific energy for three-phase fault	I ² t [MA ² s]	1296	1296	2500	4900	4900	7225	14400	14400	22500	22500
Rated short-time current of the neutral bar (1 s)	I _{cn} [kA] _{max}	-	-	-	-	-	-	-	-	-	-
Peak current of the neutral bar	I _{pn} [kA]	-	-	-	-	-	-	-	-	-	-
Rated short-time current of the protective circuit (1 s)	I _{cp} [kA] _{max}	22	22	30	42	42	51	72	72	90	90
Peak current of the protective circuit	I _{pp} [kA]	45	45	63	88	88	112	158	158	198	198
Phase resistance at 20°C	R ₃₀ [mΩ/m]	0,077	0,077	0,056	0,045	0,031	0,025	0,022	0,015	0,012	0,010
Phase reactance (50Hz)	X [mΩ/m]	0,023	0,017	0,017	0,015	0,014	0,011	0,006	0,006	0,006	0,005
Phase impedance	Z [mΩ/m]	0,080	0,079	0,059	0,047	0,034	0,027	0,023	0,017	0,014	0,011
Phase resistance at thermal conditions	R [mΩ/m]	0,101	0,102	0,076	0,062	0,043	0,035	0,032	0,022	0,018	0,014
Phase impedance at thermal conditions	Z [mΩ/m]	0,104	0,103	0,078	0,064	0,045	0,037	0,032	0,023	0,019	0,015
Neutral resistance	R ₂₀ [mΩ/m]	-	-	-	-	-	-	-	-	-	-
Functional Earth resistance (FE)	R ₂₀ [mΩ/m]	-	-	-	-	-	-	-	-	-	-
Functional Earth reactance (FE)	X [mΩ/m]	-	-	-	-	-	-	-	-	-	-
Resistance of the protective bar (PE 1)	R _{pe} [mΩ/m]	0,132	0,132	0,132	0,133	0,111	0,106	0,078	0,072	0,068	0,035
Resistance of the protective bar (PE 2)	R _{pe} [mΩ/m]	0,049	0,049	0,049	0,049	0,032	0,029	0,019	0,016	0,014	0,010
Resistance of the protective bar (PE 3)	R _{pe} [mΩ/m]	0,084	0,084	0,084	0,084	0,054	0,049	0,032	0,027	0,025	0,016
Reactance of the protective bar	X _{pe} [mΩ/m]	0,080	0,078	0,078	0,048	0,039	0,028	0,020	0,015	0,016	0,014
Resistance of the fault loop (PE 1)	R _{fa} [mΩ/m]	0,208	0,208	0,188	0,178	0,142	0,131	0,101	0,087	0,080	0,045
Resistance of the fault loop (PE 2)	R _{fa} [mΩ/m]	0,126	0,126	0,106	0,094	0,063	0,054	0,041	0,031	0,027	0,019
Resistance of the fault loop (PE 3)	R _{fa} [mΩ/m]	0,161	0,161	0,140	0,129	0,085	0,074	0,054	0,043	0,037	0,026
Reactance of the fault loop (50Hz)	X _{fa} [mΩ/m]	0,10	0,10	0,10	0,06	0,05	0,04	0,03	0,02	0,02	0,02
Impedance of the fault loop (PE 1)	Z _{fa} [mΩ/m]	0,232	0,229	0,210	0,189	0,151	0,137	0,104	0,089	0,083	0,049
Impedance of the fault loop (PE 2)	Z _{fa} [mΩ/m]	0,163	0,158	0,142	0,114	0,082	0,067	0,049	0,038	0,035	0,027
Impedance of the fault loop (PE 3)	Z _{fa} [mΩ/m]	0,191	0,187	0,169	0,144	0,100	0,084	0,060	0,047	0,043	0,032
Zero-sequence short-circuit average resistance phase - N	R ₀ [mΩ/m]	-	-	-	-	-	-	-	-	-	-
Zero-sequence short-circuit average reactance phase - N	X ₀ [mΩ/m]	-	-	-	-	-	-	-	-	-	-
Zero-sequence short-circuit average impedance phase - N	Z ₀ [mΩ/m]	-	-	-	-	-	-	-	-	-	-
Zero-sequence short-circuit average resistance phase - PE	R ₀ [mΩ/m]	0,157	0,157	0,150	0,148	0,121	0,115	0,086	0,077	0,072	0,039
Zero-sequence short-circuit average reactance phase - PE	X ₀ [mΩ/m]	0,088	0,084	0,084	0,053	0,044	0,032	0,022	0,017	0,018	0,016
Zero-sequence short-circuit average impedance phase - PE	Z ₀ [mΩ/m]	0,180	0,178	0,172	0,157	0,129	0,119	0,088	0,079	0,074	0,042
Voltage drop with distributed load ΔV [V/(m*A)]10 ⁻⁶	cosφ = 0,70	75,6	72,1	56,5	47,0	34,7	27,9	23,0	17,2	14,6	11,5
	cosφ = 0,75	79,0	75,7	59,0	49,0	36,0	28,9	24,1	17,9	15,1	11,9
	cosφ = 0,80	82,1	79,2	61,3	50,9	37,1	29,9	25,1	18,5	15,6	12,2
	cosφ = 0,85	85,1	82,6	63,5	52,7	38,1	30,7	26,1	19,1	16,0	12,5
	cosφ = 0,90	87,7	85,6	65,5	54,2	38,8	31,3	27,0	19,6	16,3	12,7
	cosφ = 0,95	89,6	88,2	66,9	55,3	39,2	31,7	27,8	19,9	16,4	12,8
	cosφ = 1,00	87,7	88,0	65,6	53,9	37,3	30,2	27,5	19,3	15,6	12,0
Weight (PE 1)	p [kg/m]	14,5	14,5	15,8	16,9	22,0	25,1	32,6	40,2	45,8	79,7
Weight (PE 2)	p [kg/m]	17,8	17,8	19,1	20,2	27,1	30,8	41,3	50,5	57,1	96,7
Weight (PE 3)	p [kg/m]	15,5	15,5	16,9	18,0	23,6	27,0	35,4	43,6	49,5	85,2
Fire load	[kWh/m]	3,4	4,1	4,1	4,5	6,4	7,9	12,0	14,3	15,8	14,8
Degree of protection	IP	55/65*	55/65*	55/65*	55/65*	55/65*	55/65*	55/65*	55/65*	55/65*	55/65*
Insulation material thermal resistance class	B/F**	B/F**	B/F**	B/F**	B/F**	B/F**	B/F**	B/F**	B/F**	B/F**	B/F**
Losses for the Joule effect at nominal current	P [W/m]	121	195	227	292	330	418	596	683	863	1042
Ambient temperature min/MAX (daily average)***	[°C]	-5/70	-5/70	-5/70	-5/70	-5/70	-5/70	-5/70	-5/70	-5/70	-5/70

* IP65 available under request for feeder lines

** Class F available under request

*** Over 50° C it will be necessary to derate the busbar and for ambient temperatures under -5° C contact the technical support.

The data on this page refer to the 50 Hz frequency. For 60 Hz, please contact Starline

XCP - Xtra Compact high power busbar system

Reference(s) :
see relative catalogue for detailed reference tables

C) Technical data

C.4.1 XCP-HP COPPER (4 Conductors): 3P+N+PE

Rated current	I _n [A]	SINGLE BAR						DOUBLE BAR			TRIPLE BAR
		800	1000	1250	1600	2000	2500	3200	4000	5000	6300
Overall dimension of the busbars	L x H [mm]	125 x 130	125 x 130	125 x 130	125 x 170	125 x 170	125 x 220	125 x 380	125 x 440	125 x 480	125 x 680
Rated operational voltage	U _e [V]	1000	1000	1000	1000	1000	1000	1000	1000	1000	1000
Rated insulation voltage	U _i [V]	1000	1000	1000	1000	1000	1000	1000	1000	1000	1000
Frequency	f [Hz]	50/60	50/60	50/60	50/60	50/60	50/60	50/60	50/60	50/60	50/60
Rated short-time current (1 s)	I _{sw} [kA] _{rms}	36	50	70	70	85	120	120	150	150	150
Peak current	I _{pk} [kA]	76	105	154	154	187	264	264	330	330	330
Allowable specific energy for three-phase fault	I ² t [MA ² s]	1296	2500	4900	4900	7225	14400	14400	22500	22500	22500
Rated short-time current of the neutral bar (1 s)	I _{sw} [kA] _{rms}	22	30,0	42	42	51	72	72	90	90	90
Peak current of the neutral bar	I _{pk} [kA]	45	63	88	88	112	158	158	198	198	198
Rated short-time current of the protective circuit (1 s)	I _{sw} [kA] _{rms}	22	30,0	42	42	51	72	72	90	90	90
Peak current of the protective circuit	I _{pk} [kA]	45	63	88	88	112	158	158	198	198	198
Phase resistance at 20°C	R ₂₀ [mΩ/m]	0,077	0,045	0,038	0,034	0,018	0,015	0,013	0,009	0,006	0,006
Phase reactance (50Hz)	X [mΩ/m]	0,023	0,017	0,017	0,015	0,014	0,011	0,007	0,006	0,006	0,004
Phase impedance	Z [mΩ/m]	0,080	0,048	0,042	0,037	0,023	0,018	0,015	0,011	0,009	0,007
Phase resistance at thermal conditions	R [mΩ/m]	0,100	0,055	0,048	0,044	0,024	0,019	0,017	0,012	0,009	0,008
Phase impedance at thermal conditions	Z [mΩ/m]	0,103	0,058	0,051	0,047	0,028	0,022	0,019	0,014	0,011	0,009
Neutral resistance	R ₂₀ [mΩ/m]	0,077	0,045	0,038	0,034	0,018	0,015	0,013	0,009	0,006	0,006
Functional Earth resistance (FE)	R ₂₀ [mΩ/m]	-	-	-	-	-	-	-	-	-	-
Functional Earth reactance (FE)	X [mΩ/m]	-	-	-	-	-	-	-	-	-	-
Resistance of the protective bar (PE 1)	R _{PE} [mΩ/m]	0,132	0,132	0,132	0,119	0,119	0,106	0,078	0,072	0,068	0,037
Resistance of the protective bar (PE 2)	R _{PE} [mΩ/m]	0,049	0,049	0,049	0,038	0,038	0,014	0,019	0,016	0,014	0,011
Resistance of the protective bar (PE 3)	R _{PE} [mΩ/m]	0,084	0,084	0,084	0,064	0,064	0,025	0,032	0,025	0,023	0,018
Reactance of the protective bar	X _{PE} [mΩ/m]	0,054	0,054	0,054	0,044	0,044	0,032	0,022	0,017	0,016	0,014
Resistance of the fault loop (PE 1)	R _{fa} [mΩ/m]	0,209	0,176	0,170	0,153	0,137	0,121	0,091	0,081	0,074	0,043
Resistance of the fault loop (PE 2)	R _{fa} [mΩ/m]	0,126	0,094	0,087	0,072	0,056	0,029	0,032	0,025	0,021	0,016
Resistance of the fault loop (PE 3)	R _{fa} [mΩ/m]	0,16	0,13	0,12	0,10	0,08	0,04	0,05	0,03	0,03	0,02
Reactance of the fault loop (50Hz)	X _{fa} [mΩ/m]	0,077	0,071	0,071	0,059	0,058	0,043	0,029	0,023	0,022	0,018
Impedance of the fault loop (PE 1)	Z _{fa} [mΩ/m]	0,222	0,190	0,184	0,164	0,149	0,129	0,096	0,084	0,078	0,046
Impedance of the fault loop (PE 2)	Z _{fa} [mΩ/m]	0,148	0,118	0,113	0,093	0,081	0,052	0,043	0,034	0,030	0,024
Impedance of the fault loop (PE 3)	Z _{fa} [mΩ/m]	0,179	0,147	0,141	0,114	0,101	0,058	0,054	0,042	0,037	0,030
Zero-sequence short-circuit average resistance phase - N	R ₀ [mΩ/m]	0,103	0,060	0,050	0,045	0,025	0,020	0,018	0,012	0,009	0,008
Zero-sequence short-circuit average reactance phase - N	X ₀ [mΩ/m]	0,031	0,023	0,023	0,020	0,019	0,015	0,009	0,008	0,008	0,005
Zero-sequence short-circuit average impedance phase - N	Z ₀ [mΩ/m]	0,107	0,064	0,055	0,050	0,031	0,025	0,020	0,015	0,012	0,009
Zero-sequence short-circuit average resistance phase - PE	R ₀ [mΩ/m]	0,157	0,147	0,144	0,130	0,125	0,111	0,083	0,075	0,070	0,039
Zero-sequence short-circuit average reactance phase - PE	X ₀ [mΩ/m]	0,062	0,060	0,060	0,049	0,049	0,036	0,024	0,019	0,018	0,015
Zero-sequence short-circuit average impedance phase - PE	Z ₀ [mΩ/m]	0,2	0,2	0,2	0,1	0,1	0,1	0,1	0,1	0,1	0,0
Voltage drop with distributed load ΔV [V/(m*A)]10 ⁻⁴	cosφ = 0,70	74,9	43,9	39,4	36,1	23,3	18,5	14,8	11,1	9,0	7,1
	cosφ = 0,75	78,2	45,5	40,7	37,3	23,7	18,8	15,2	11,4	9,1	7,2
	cosφ = 0,80	81,3	47,0	41,9	38,4	24,0	19,0	15,6	11,6	9,1	7,3
	cosφ = 0,85	84,1	48,3	42,9	39,4	24,1	19,2	15,9	11,8	9,1	7,4
	cosφ = 0,90	86,7	49,3	43,6	40,1	24,1	19,1	16,1	11,8	9,0	7,4
	cosφ = 0,95	88,5	49,9	43,9	40,4	23,6	18,8	16,1	11,7	8,7	7,3
	cosφ = 1,00	86,7	47,7	41,3	38,3	20,9	16,6	14,9	10,6	7,5	6,6
Weight (PE 1)	p [kg/m]	21,2	26,9	29,6	33,5	50,4	62,2	74,2	97,9	130,3	173,6
Weight (PE 2)	p [kg/m]	24,5	30,2	32,9	37,8	54,8	73,6	83,0	108,2	141,6	189,1
Weight (PE 3)	p [kg/m]	22,3	28,0	30,7	34,9	51,8	65,9	77,1	101,5	134,2	178,7
Fire load	[kWh/m]	4,5	5,5	5,5	8	8,2	10,5	16	19	21	22
Degree of protection	IP	55/65*	55/65*	55/65*	55/65*	55/65*	55/65*	55/65*	55/65*	55/65*	55/65*
Insulation material thermal resistance class		B/F**	B/F**	B/F**	B/F**	B/F**	B/F**	B/F**	B/F**	B/F**	B/F**
Losses for the Joule effect at nominal current	P [W/m]	192	165	224	339	289	360	529	588	648	901
Ambient temperature min/MAX (daily average)***	[°C]	-5/70	-5/70	-5/70	-5/70	-5/70	-5/70	-5/70	-5/70	-5/70	-5/70

* IP65 available under request for feeder lines

** Class F available under request

*** Over 55° C it will be necessary to derate the busbar and for ambient temperatures under -5° C contact the technical support.

The data on this page refer to the 50 Hz frequency. For 60 Hz, please contact Starline

XCP - Xtra Compact high power busbar system

Reference(s) :

see relative catalogue for detailed reference tables

C) Technical data

C.4.2 XCP-HP COPPER (5 Conductors - clean earth): 3P+N+PE+FE

Rated current	I _n [A]	SINGLE BAR						DOUBLE BAR			TRIPLE BAR
		800	1000	1250	1600	2000	2500	3200	4000	5000	6300
Overall dimension of the busbars	L x H [mm]	125 x 130	125 x 130	125 x 130	125 x 170	125 x 170	125 x 220	125 x 380	125 x 440	125 x 480	125 x 680
Rated operational voltage	U _e [V]	1000	1000	1000	1000	1000	1000	1000	1000	1000	1000
Rated insulation voltage	U _i [V]	1000	1000	1000	1000	1000	1000	1000	1000	1000	1000
Frequency	f [Hz]	50/60	50/60	50/60	50/60	50/60	50/60	50/60	50/60	50/60	50/60
Rated short-time current (1 s)	I _{cw} [kA] _{rms}	36	50	70	70	85	120	120	150	150	150
Peak current	I _{pk} [kA]	76	105	154	154	187	264	264	330	330	330
Allowable specific energy for three-phase fault	I ² t [MA ² s]	1296	2500	4900	4900	7225	14400	14400	22500	22500	22500
Rated short-time current of the neutral bar (1 s)	I _{cn} [kA] _{rms}	22	30	42	42	51	72	72	90	90	90
Peak current of the neutral bar	I _{pn} [kA]	45	63	88	88	112	158	158	198	198	198
Rated short-time current of the protective circuit (1 s)	I _{cp} [kA] _{rms}	22	30	42	42	51	72	72	90	90	90
Peak current of the protective circuit	I _{pp} [kA]	45	63	88	88	112	158	158	198	198	198
Phase resistance at 20°C	R ₃₀ [mΩ/m]	0,077	0,045	0,038	0,034	0,018	0,015	0,013	0,009	0,006	0,006
Phase reactance (50hz)	X [mΩ/m]	0,023	0,017	0,017	0,015	0,014	0,011	0,007	0,006	0,006	0,004
Phase impedance	Z [mΩ/m]	0,080	0,048	0,042	0,037	0,023	0,018	0,015	0,011	0,009	0,007
Phase resistance at thermal conditions	R [mΩ/m]	0,100	0,055	0,048	0,044	0,024	0,019	0,017	0,012	0,009	0,008
Phase impedance at thermal conditions	Z [mΩ/m]	0,103	0,058	0,051	0,047	0,028	0,022	0,019	0,014	0,011	0,009
Neutral resistance	R ₃₀ [mΩ/m]	0,077	0,045	0,038	0,034	0,018	0,015	0,013	0,009	0,006	0,006
Functional Earth resistance (FE)	R ₃₀ [mΩ/m]	0,077	0,045	0,038	0,034	0,018	0,015	0,013	0,009	0,006	0,006
Functional Earth reactance (FE)	X [mΩ/m]	0,023	0,017	0,017	0,015	0,014	0,011	0,007	0,006	0,006	0,004
Resistance of the protective bar (PE 1)	R _{pe} [mΩ/m]	0,132	0,132	0,132	0,119	0,122	0,108	0,078	0,072	0,068	0,037
Resistance of the protective bar (PE 2)	R _{pe} [mΩ/m]	0,049	0,049	0,049	0,038	0,038	0,014	0,019	0,016	0,014	0,011
Resistance of the protective bar (PE 3)	R _{pe} [mΩ/m]	0,084	0,084	0,084	0,064	0,064	0,025	0,032	0,025	0,023	0,021
Reactance of the protective bar	X _{pe} [mΩ/m]	0,054	0,054	0,054	0,044	0,044	0,032	0,022	0,017	0,016	0,014
Resistance of the fault loop (PE 1)	R _n [mΩ/m]	0,126	0,078	0,067	0,060	0,035	0,028	0,024	0,018	0,012	0,011
Resistance of the fault loop (PE 2)	R _n [mΩ/m]	0,107	0,068	0,059	0,052	0,031	0,022	0,021	0,015	0,011	0,009
Resistance of the fault loop (PE 3)	R _n [mΩ/m]	0,12	0,07	0,06	0,06	0,03	0,02	0,02	0,02	0,01	0,01
Reactance of the fault loop (50hz)	X _n [mΩ/m]	0,077	0,071	0,071	0,059	0,058	0,043	0,029	0,023	0,022	0,018
Impedance of the fault loop (PE 1)	Z _n [mΩ/m]	0,147	0,106	0,098	0,084	0,067	0,051	0,038	0,029	0,025	0,021
Impedance of the fault loop (PE 2)	Z _n [mΩ/m]	0,132	0,098	0,093	0,079	0,066	0,048	0,036	0,028	0,025	0,020
Impedance of the fault loop (PE 3)	Z _n [mΩ/m]	0,140	0,102	0,096	0,081	0,067	0,049	0,037	0,028	0,025	0,021
Zero-sequence short-circuit average resistance phase - N	R ₀ [mΩ/m]	0,103	0,060	0,050	0,045	0,025	0,020	0,018	0,012	0,009	0,008
Zero-sequence short-circuit average reactance phase - N	X ₀ [mΩ/m]	0,031	0,023	0,023	0,020	0,019	0,015	0,009	0,008	0,008	0,005
Zero-sequence short-circuit average impedance phase - N	Z ₀ [mΩ/m]	0,107	0,064	0,055	0,050	0,031	0,025	0,020	0,015	0,012	0,009
Zero-sequence short-circuit average resistance phase - PE	R ₀ [mΩ/m]	0,103	0,060	0,050	0,045	0,025	0,020	0,018	0,012	0,009	0,008
Zero-sequence short-circuit average reactance phase - PE	X ₀ [mΩ/m]	0,031	0,023	0,023	0,020	0,019	0,015	0,009	0,008	0,008	0,005
Zero-sequence short-circuit average impedance phase - PE	Z ₀ [mΩ/m]	0,107	0,064	0,055	0,050	0,031	0,025	0,020	0,015	0,012	0,009
Voltage drop with distributed load ΔV [V/(m*A)]10 ⁻⁶	cosφ = 0,70	74,9	43,9	39,4	36,1	23,3	18,5	14,8	11,1	9,0	7,1
	cosφ = 0,75	78,2	45,5	40,7	37,3	23,7	18,8	15,2	11,4	9,1	7,2
	cosφ = 0,80	81,3	47,0	41,9	38,4	24,0	19,0	15,6	11,6	9,1	7,3
	cosφ = 0,85	84,1	48,3	42,9	39,4	24,1	19,2	15,9	11,8	9,1	7,4
	cosφ = 0,90	86,7	49,3	43,6	40,1	24,1	19,1	16,1	11,8	9,0	7,4
	cosφ = 0,95	88,5	49,9	43,9	40,4	23,6	18,8	16,1	11,7	8,7	7,3
cosφ = 1,00	86,7	47,7	41,3	38,3	20,9	16,6	14,9	10,6	7,5	6,6	
Weight (PE 1)	p [kg/m]	23,8	31,1	34,5	39,0	59,9	74,3	88,2	117,3	157,4	200,3
Weight (PE 2)	p [kg/m]	27,2	34,5	37,8	43,4	64,3	85,6	96,9	127,6	168,8	215,7
Weight (PE 3)	p [kg/m]	24,9	32,2	35,5	40,4	61,3	78,0	91,1	120,8	161,4	204,5
Fire load	[kWh/m]	5,625	6,875	6,875	10	10,25	13,125	20	23,75	26,25	27,25
Degree of protection	IP	55/65*	55/65*	55/65*	55/65*	55/65*	55/65*	55/65*	55/65*	55/65*	55/65*
Insulation material thermal resistance class		B/F**	B/F**	B/F**	B/F**	B/F**	B/F**	B/F**	B/F**	B/F**	B/F**
Losses for the Joule effect at nominal current	P [W/m]	192	165	224	339	289	360	529	588	648	901
Ambient temperature min/MAX (daily average)***	[°C]	-5/70	-5/70	-5/70	-5/70	-5/70	-5/70	-5/70	-5/70	-5/70	-5/70

* IP65 available under request for feeder lines

** Class F available under request

*** Over 55° C it will be necessary to derate the busbar and for ambient temperatures under -5° C contact the technical support.

The data on this page refer to the 50 Hz frequency. For 60 Hz, please contact Starline

XCP - Xtra Compact high power busbar system

Reference(s) :

see relative catalogue for detailed reference tables

C) Technical data

C.4.3 XCP-HP COPPER (5 Conductors – double neutral): 3P+2N+PE

Rated current	I _n [A]	SINGLE BAR						DOUBLE BAR			TRIPLE BAR
		800	1000	1250	1600	2000	2500	3200	4000	5000	6300
Overall dimension of the busbars	L x H [mm]	125 x 130	125 x 130	125 x 130	125 x 170	125 x 170	125 x 220	125 x 380	125 x 440	125 x 480	125 x 680
Rated operational voltage	U _e [V]	1000	1000	1000	1000	1000	1000	1000	1000	1000	1000
Rated insulation voltage	U _i [V]	1000	1000	1000	1000	1000	1000	1000	1000	1000	1000
Frequency	f [Hz]	50/60	50/60	50/60	50/60	50/60	50/60	50/60	50/60	50/60	50/60
Rated short-time current (1 s)	I _{CS} [kA] _{1ms}	36	50	70	70	85	120	120	150	150	150
Peak current	I _{pk} [kA]	76	105	154	154	187	264	264	330	330	330
Allowable specific energy for three-phase fault	I ² t [MA ² s]	1296	2500	4900	4900	7225	14400	14400	22500	22500	22500
Rated short-time current of the neutral bar (1 s)	I _{CSN} [kA] _{1ms}	22	30	42	42	51	72	72	90	90	90
Peak current of the neutral bar	I _{pkN} [kA]	45	63	88	88	112	158	158	198	198	198
Rated short-time current of the protective circuit (1 s)	I _{CSPC} [kA] _{1ms}	22	30	42	42	51	72	72	90	90	90
Peak current of the protective circuit	I _{pkPC} [kA]	22	63	88	88	112	158	158	198	198	198
Phase resistance at 20°C	R ₂₀ [mΩ/m]	0,077	0,045	0,038	0,034	0,018	0,015	0,013	0,009	0,006	0,006
Phase reactance (50hz)	X [mΩ/m]	0,023	0,017	0,017	0,015	0,014	0,011	0,007	0,006	0,006	0,004
Phase impedance	Z [mΩ/m]	0,080	0,048	0,042	0,037	0,023	0,018	0,015	0,011	0,009	0,007
Phase resistance at thermal conditions	R [mΩ/m]	0,100	0,055	0,048	0,044	0,024	0,019	0,017	0,012	0,009	0,008
Phase impedance at thermal conditions	Z [mΩ/m]	0,103	0,058	0,051	0,047	0,028	0,022	0,019	0,014	0,011	0,009
Neutral resistance	R ₂₀ [mΩ/m]	0,038	0,022	0,019	0,017	0,009	0,007	0,007	0,005	0,003	0,003
Functional Earth resistance (FE)	R ₂₀ [mΩ/m]	-	-	-	-	-	-	-	-	-	-
Functional Earth reactance (FE)	X [mΩ/m]	-	-	-	-	-	-	-	-	-	-
Resistance of the protective bar (PE 1)	R _{PE} [mΩ/m]	0,132	0,132	0,132	0,119	0,122	0,108	0,078	0,072	0,068	0,037
Resistance of the protective bar (PE 2)	R _{PE} [mΩ/m]	0,049	0,049	0,049	0,038	0,038	0,014	0,019	0,016	0,014	0,011
Resistance of the protective bar (PE 3)	R _{PE} [mΩ/m]	0,084	0,084	0,084	0,064	0,064	0,025	0,032	0,025	0,023	0,021
Reactance of the protective bar	X _{PE} [mΩ/m]	0,054	0,054	0,054	0,044	0,044	0,032	0,022	0,017	0,016	0,014
Resistance of the fault loop (PE 1)	R _o [mΩ/m]	0,209	0,176	0,170	0,153	0,140	0,123	0,091	0,081	0,075	0,043
Resistance of the fault loop (PE 2)	R _o [mΩ/m]	0,126	0,094	0,087	0,072	0,056	0,029	0,032	0,025	0,021	0,016
Resistance of the fault loop (PE 3)	R _o [mΩ/m]	0,16	0,13	0,12	0,10	0,08	0,04	0,05	0,03	0,03	0,03
Reactance of the fault loop (50hz)	X _o [mΩ/m]	0,077	0,071	0,071	0,059	0,058	0,043	0,029	0,023	0,022	0,018
Impedance of the fault loop (PE 1)	Z _o [mΩ/m]	0,222	0,190	0,184	0,164	0,152	0,130	0,096	0,084	0,078	0,047
Impedance of the fault loop (PE 2)	Z _o [mΩ/m]	0,148	0,118	0,113	0,093	0,081	0,052	0,043	0,034	0,030	0,024
Impedance of the fault loop (PE 3)	Z _o [mΩ/m]	0,179	0,147	0,141	0,114	0,101	0,058	0,054	0,042	0,037	0,032
Zero-sequence short-circuit average resistance phase - N	R _o [mΩ/m]	0,064	0,037	0,032	0,028	0,015	0,012	0,011	0,008	0,005	0,005
Zero-sequence short-circuit average reactance phase - N	X _o [mΩ/m]	0,019	0,014	0,014	0,013	0,012	0,009	0,006	0,005	0,005	0,003
Zero-sequence short-circuit average impedance phase - N	Z _o [mΩ/m]	0,067	0,040	0,035	0,031	0,019	0,015	0,012	0,009	0,007	0,006
Zero-sequence short-circuit average resistance phase - PE	R _o [mΩ/m]	0,157	0,147	0,144	0,130	0,125	0,111	0,083	0,075	0,070	0,039
Zero-sequence short-circuit average reactance phase - PE	X _o [mΩ/m]	0,062	0,060	0,060	0,049	0,049	0,036	0,024	0,019	0,018	0,015
Zero-sequence short-circuit average impedance phase - PE	Z _o [mΩ/m]	0,169	0,158	0,156	0,139	0,134	0,117	0,086	0,077	0,072	0,042
Voltage drop with distributed load ΔV [V/(m*A)]10 ⁻⁶	cosφ = 0,70	74,9	43,9	39,4	36,1	23,3	18,5	14,8	11,1	9,0	7,1
	cosφ = 0,75	78,2	45,5	40,7	37,3	23,7	18,8	15,2	11,4	9,1	7,2
	cosφ = 0,80	81,3	47,0	41,9	38,4	24,0	19,0	15,6	11,6	9,1	7,3
	cosφ = 0,85	84,1	48,3	42,9	39,4	24,1	19,2	15,9	11,8	9,1	7,4
	cosφ = 0,90	86,7	49,3	43,6	40,1	24,1	19,1	16,1	11,8	9,0	7,4
	cosφ = 0,95	88,5	49,9	43,9	40,4	23,6	18,8	16,1	11,7	8,7	7,3
cosφ = 1,00	86,7	47,7	41,3	38,3	20,9	16,6	14,9	10,6	7,5	6,6	
Weight (PE 1)	p [kg/m]	23,8	31,1	34,5	39,0	59,9	74,3	88,2	117,3	157,4	200,3
Weight (PE 2)	p [kg/m]	27,2	34,5	37,8	43,4	64,3	85,6	96,9	127,6	168,8	215,7
Weight (PE 3)	p [kg/m]	24,9	32,2	35,5	40,4	61,3	78,0	91,1	120,8	161,4	204,5
Fire load	[kWh/m]	5,625	6,875	6,875	10	10,25	13,125	20	23,75	26,25	27,25
Degree of protection	IP	55/65*	55/65*	55/65*	55/65*	55/65*	55/65*	55/65*	55/65*	55/65*	55/65*
Insulation material thermal resistance class	B/F**	B/F**	B/F**	B/F**	B/F**	B/F**	B/F**	B/F**	B/F**	B/F**	B/F**
Losses for the Joule effect at nominal current	P [W/m]	192	165	224	339	289	360	529	588	648	901
Ambient temperature min/MAX (daily average)***	[°C]	-5/70	-5/70	-5/70	-5/70	-5/70	-5/70	-5/70	-5/70	-5/70	-5/70

* IP65 available under request for feeder lines

** Class F available under request

*** Over 55° C it will be necessary to derate the busbar and for ambient temperatures under -5° C contact the technical support.

The data on this page refer to the 50 Hz frequency. For 60 Hz, please contact Starline

XCP - Xtra Compact high power busbar system

Reference(s) :
see relative catalogue for detailed reference tables

C) Technical data

C.4.4 XCP-HP COPPER (3 Conductors): 3P+PE

Rated current	I _n [A]	SINGLE BAR						DOUBLE BAR			TRIPLE BAR
		800	1000	1250	1600	2000	2500	3200	4000	5000	6300
Overall dimension of the busbars	L x H [mm]	125 x 130	125 x 130	125 x 130	125 x 170	125 x 170	125 x 220	125 x 380	125 x 440	125 x 480	125 x 680
Rated operational voltage	U _e [V]	1000	1000	1000	1000	1000	1000	1000	1000	1000	1000
Rated insulation voltage	U _i [V]	1000	1000	1000	1000	1000	1000	1000	1000	1000	1000
Frequency	f [Hz]	50/60	50/60	50/60	50/60	50/60	50/60	50/60	50/60	50/60	50/60
Rated short-time current (1 s)	I _{ctw} [kA] _{1ms}	36	50	70	70	85	120	120	150	150	150
Peak current	I _{pk} [kA]	76	105	154	154	187	264	264	330	330	330
Allowable specific energy for three-phase fault	i ² t [MA ² s]	1296	2500	4900	4900	7225	14400	14400	22500	22500	22500
Rated short-time current of the neutral bar (1 s)	I _{ctw} [kA] _{1ms}	-	-	-	-	-	-	-	-	-	-
Peak current of the neutral bar	I _{pk} [kA]	-	-	-	-	-	-	-	-	-	-
Rated short-time current of the protective circuit (1 s)	I _{ctw} [kA] _{1ms}	22	30	42	42	51	72	72	90	90	90
Peak current of the protective circuit	I _{pk} [kA]	45	63	88	88	112	158	158	198	198	198
Phase resistance at 20°C	R ₂₀ [mΩ/m]	0,077	0,045	0,038	0,034	0,018	0,015	0,013	0,009	0,006	0,006
Phase reactance (50Hz)	X [mΩ/m]	0,023	0,017	0,017	0,015	0,014	0,011	0,007	0,006	0,006	0,004
Phase impedance	Z [mΩ/m]	0,080	0,048	0,042	0,037	0,023	0,018	0,015	0,011	0,009	0,007
Phase resistance at thermal conditions	R [mΩ/m]	0,100	0,055	0,048	0,044	0,024	0,019	0,017	0,012	0,009	0,008
Phase impedance at thermal conditions	Z [mΩ/m]	0,103	0,058	0,051	0,047	0,028	0,022	0,019	0,014	0,011	0,009
Neutral resistance	R ₂₀ [mΩ/m]	-	-	-	-	-	-	-	-	-	-
Functional Earth resistance (FE)	R ₂₀ [mΩ/m]	-	-	-	-	-	-	-	-	-	-
Functional Earth reactance (FE)	X [mΩ/m]	-	-	-	-	-	-	-	-	-	-
Resistance of the protective bar (PE 1)	R _{PE} [mΩ/m]	0,130	0,130	0,130	0,118	0,110	0,089	0,078	0,071	0,067	0,040
Resistance of the protective bar (PE 2)	R _{PE} [mΩ/m]	0,049	0,049	0,049	0,038	0,038	0,014	0,019	0,016	0,014	0,011
Resistance of the protective bar (PE 3)	R _{PE} [mΩ/m]	0,084	0,084	0,084	0,064	0,064	0,025	0,032	0,025	0,023	0,021
Reactance of the protective bar	X _{PE} [mΩ/m]	0,054	0,054	0,054	0,044	0,044	0,032	0,022	0,017	0,016	0,014
Resistance of the fault loop (PE 1)	R _o [mΩ/m]	0,206	0,174	0,167	0,152	0,128	0,104	0,091	0,080	0,074	0,045
Resistance of the fault loop (PE 2)	R _o [mΩ/m]	0,126	0,094	0,087	0,072	0,056	0,029	0,032	0,025	0,021	0,016
Resistance of the fault loop (PE 3)	R _o [mΩ/m]	0,16	0,13	0,12	0,10	0,08	0,04	0,05	0,03	0,03	0,03
Reactance of the fault loop (50Hz)	X _o [mΩ/m]	0,077	0,071	0,071	0,059	0,058	0,043	0,029	0,023	0,022	0,018
Impedance of the fault loop (PE 1)	Z _o [mΩ/m]	0,220	0,188	0,182	0,163	0,141	0,113	0,095	0,083	0,077	0,049
Impedance of the fault loop (PE 2)	Z _o [mΩ/m]	0,148	0,118	0,113	0,093	0,081	0,052	0,043	0,034	0,030	0,024
Impedance of the fault loop (PE 3)	Z _o [mΩ/m]	0,179	0,147	0,141	0,114	0,101	0,058	0,054	0,042	0,037	0,032
Zero-sequence short-circuit average resistance phase - N	R _o [mΩ/m]	-	-	-	-	-	-	-	-	-	-
Zero-sequence short-circuit average reactance phase - N	X _o [mΩ/m]	-	-	-	-	-	-	-	-	-	-
Zero-sequence short-circuit average impedance phase - N	Z _o [mΩ/m]	-	-	-	-	-	-	-	-	-	-
Zero-sequence short-circuit average resistance phase - PE	R _o [mΩ/m]	0,157	0,147	0,144	0,130	0,125	0,111	0,083	0,075	0,070	0,039
Zero-sequence short-circuit average reactance phase - PE	X _o [mΩ/m]	0,062	0,060	0,060	0,049	0,049	0,036	0,024	0,019	0,018	0,015
Zero-sequence short-circuit average impedance phase - PE	Z _o [mΩ/m]	0,2	0,2	0,2	0,1	0,1	0,1	0,1	0,1	0,1	0,0
Voltage drop with distributed load ΔV [V/(m*A)]10 ⁻⁶	cosφ = 0,70	74,9	43,9	39,4	36,1	23,3	18,5	14,8	11,1	9,0	7,1
	cosφ = 0,75	78,2	45,5	40,7	37,3	23,7	18,8	15,2	11,4	9,1	7,2
	cosφ = 0,80	81,3	47,0	41,9	38,4	24,0	19,0	15,6	11,6	9,1	7,3
	cosφ = 0,85	84,1	48,3	42,9	39,4	24,1	19,2	15,9	11,8	9,1	7,4
	cosφ = 0,90	86,7	49,3	43,6	40,1	24,1	19,1	16,1	11,8	9,0	7,4
	cosφ = 0,95	88,5	49,9	43,9	40,4	23,6	18,8	16,1	11,7	8,7	7,3
cosφ = 1,00	86,7	47,7	41,3	38,3	20,9	16,6	14,9	10,6	7,5	6,6	
Weight (PE 1)	p [kg/m]	18,7	22,9	24,9	28,0	41,6	52,2	60,3	78,6	103,2	136,2
Weight (PE 2)	p [kg/m]	22,0	26,2	28,2	32,4	45,9	63,5	69,0	88,9	114,5	151,6
Weight (PE 3)	p [kg/m]	19,7	23,9	25,9	29,5	43,0	55,8	63,1	82,2	107,1	140,4
Fire load	[kWh/m]	3,375	4,125	4,125	6	6,15	7,875	12	14,25	15,75	16,75
Degree of protection	IP	55/65*	55/65*	55/65*	55/65*	55/65*	55/65*	55/65*	55/65*	55/65*	55/65*
Insulation material thermal resistance class		B/F**	B/F**	B/F**	B/F**	B/F**	B/F**	B/F**	B/F**	B/F**	B/F**
Losses for the Joule effect at nominal current	P [W/m]	192	165	224	339	289	360	529	588	648	901
Ambient temperature min/MAX (daily average)***	[°C]	-5/70	-5/70	-5/70	-5/70	-5/70	-5/70	-5/70	-5/70	-5/70	-5/70

* IP65 available under request for feeder lines

** Class F available under request

*** Over 55° C it will be necessary to derate the busbar and for ambient temperatures under -5° C contact the technical support.

The data on this page refer to the 50 Hz frequency. For 60 Hz, please contact Starline