

Comparing Pipe and Wire to Busway Installations for EVSE

TRADITIONAL PIPE AND WIRE INSTALLATION

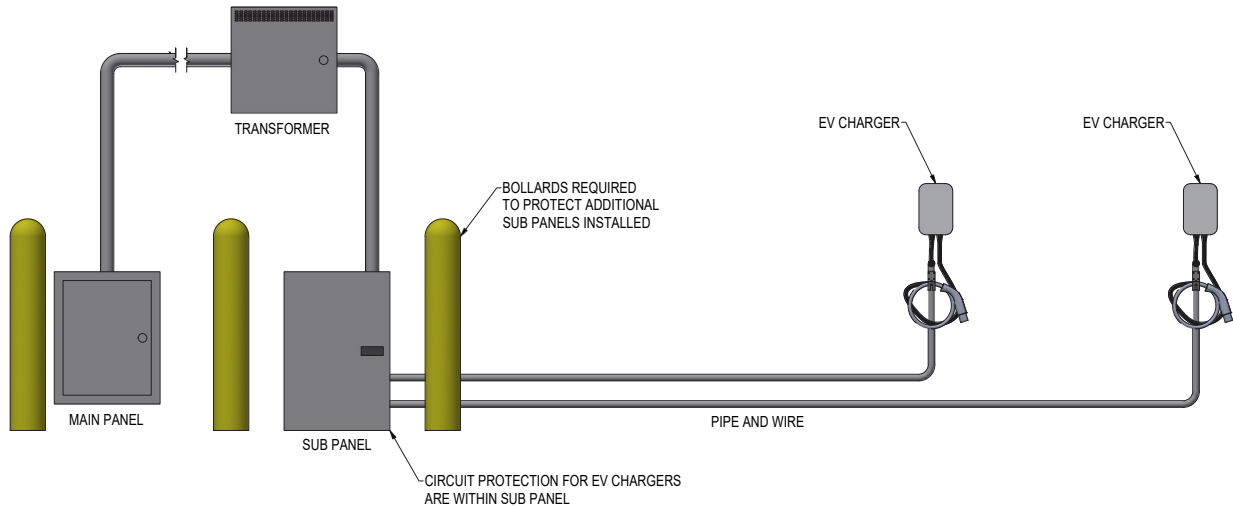

SERIES-S TRACK BUSWAY INSTALLATION

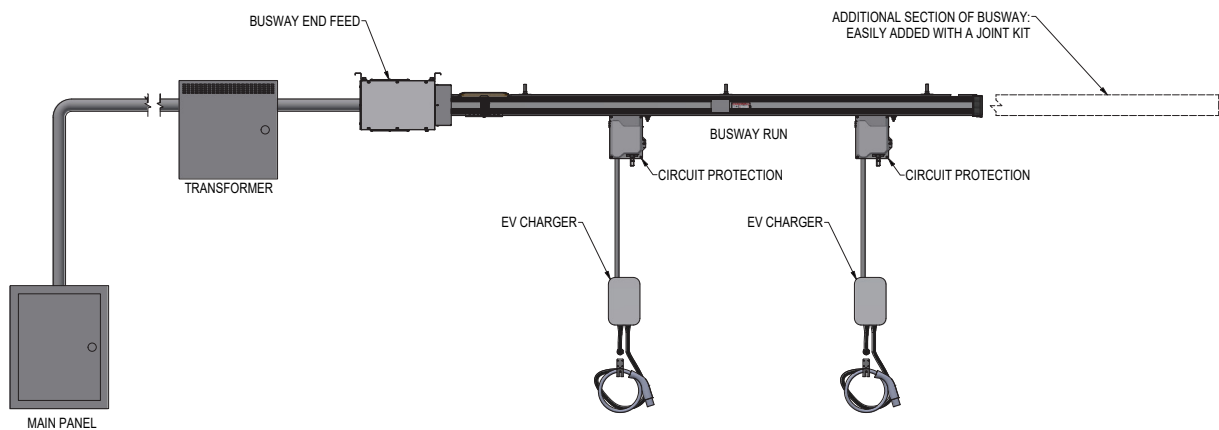

Why choose track busway over traditional pipe and wire?

- **Reduced Feeders:** Minimize the number of feeders required from the electrical main
- **Integrated Panelboards:** Busway plug-in units serve as panelboards, eliminating the need for additional subpanels
- **Overhead Solution:** Busway's overhead placement means no need for bollards or other barrier protection
- **Point-of-Use Power:** Deliver power directly to each charger, with circuit protection right at the point of use