

MDF & IDF Applications





Offering Overview

Starline has made it even easier for our Track Busway and Critical Power Monitor (CPM) products to be used in independent distribution facility (IDF) rooms and smaller main distribution facility (MDF) applications within your building. The end feed units are directly incorporated onto busway sections of varying lengths, saving both installation time and pluggable space. Our cabinet mounting brackets also permit the products to be used in rooms where ceiling height and mounting equipment from above are limitations. For metering needs, the Starline CPM provides the necessary information to understand your loading and revenue-grade power usage, and can be incorporated in both end feed and plug-in unit applications.



Starline IDF installation example

BENEFITS

-  Faster installation
-  Smaller footprint
-  Easily configured
-  Customized options

Elevation View & Product Numbers

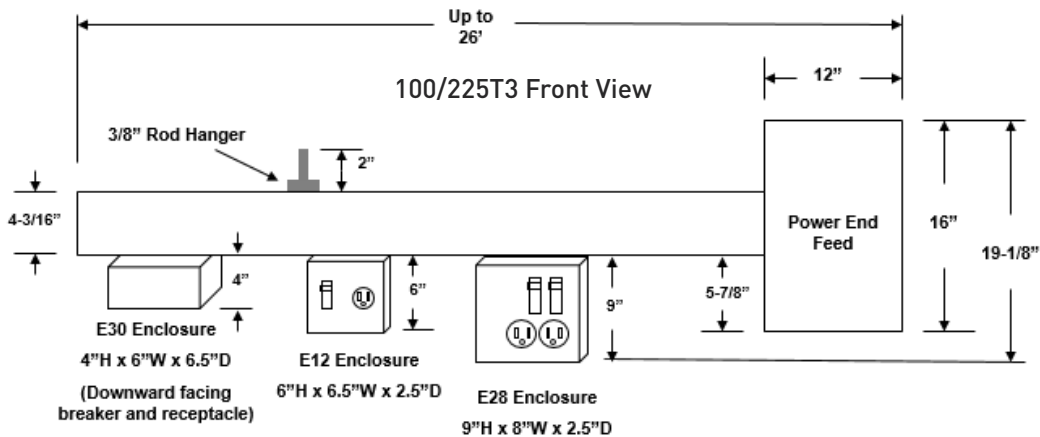

PRODUCT NUMBER BREAKDOWN

System	Product Frame/ Compatibility	-	Neutral/Ground Busbar	Polarization	-	System Length	-	Meter	-	Kit Identifier
U (U.S.) M (Metric)	100T3 225T3 250T5	-	4 N G F	S (Standard) R (Reversed)	-	XXYY (XX=feet, YY=inches) MXY (X=meters, YY=centimeters)	-	M41P3	-	IDF-MDF-KIT

StarlinePower.com

+1 724-597-7800 | +1 800-245-6378

01/20 F0900027

Starline
A brand of  Legrand

MDF & IDF Applications

Common Plug-in Units

PRODUCT NUMBERS	
CBT5E92-520D-4	CBDC225E92-X-L620C-4
CBDCT5E92-X-520Q-4	CBDC225E92-X-L630C-4
CBDCT5E92-X-L520C-4-V51S	CBDCT5E92-X-L2120C-4
CB225E92-L620-4	CBDCT5E92-X-L2130C-4
CB225E92-L630-4	CBDCT5HE52-X-L2230C-4
CB225E30-L1530-4	

*For IEC plug-in units add a 'GM' to the front of the product number

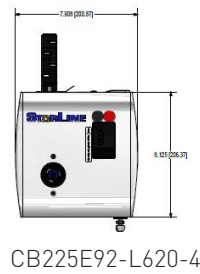

For other plug-in unit configurations, please consult your sales representative.

Metering Options

The Starline Critical Power Monitor (CPM) creates value for your MDF/IDF application by providing the critical information needed to optimize management and efficiency. With both end feed and plug-in unit versions available, this revenue-grade power monitor gives you the ability to measure your usage on both the entire busway run and the cabinet/rack level. The CPM supports both serial and Ethernet-based communications, with all the standard protocols including Modbus (RTU and TCP), SNMP, BACNet TCP, and has a built-in integral webpage for easy setup and installation.



Accessories

Universal Server Cabinet Mounting Bracket

- Quick and simple installation with no ceiling support required
- Cost savings from decreased labor and equipment
- Accommodates 10 feet (3m) of busway per mounting bracket; approx. 2x the length of most other mounting methods

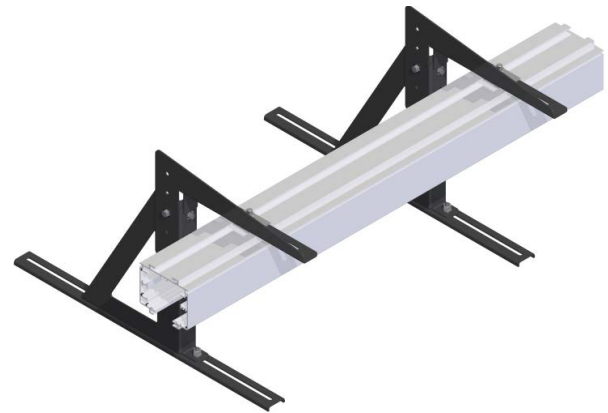

	30" cabinet depth	36" cabinet depth	42" cabinet depth	48" cabinet depth
T3	UUSCMB-T3-30-C MUSCMB-T3-762-C	UUSCMB-T3-36-C MUSCMB-T3-914-C	UUSCMB-T3-42-C MUSCMB-T3-1067-C	UUSCMB-T3-48-C MUSCMB-T3-1219-C
T5	UUSCMB-T5-30-C MUSCMB-T5-762-C	UUSCMB-T5-36-C MUSCMB-T5-914-C	UUSCMB-T5-42-C MUSCMB-T5-1067-C	UUSCMB-T5-48-C MUSCMB-T5-1219-C

StarlinePower.com

+1 724-597-7800 | +1 800-245-6378

01/20 F0900027

Starline
A brand of **Legrand**